

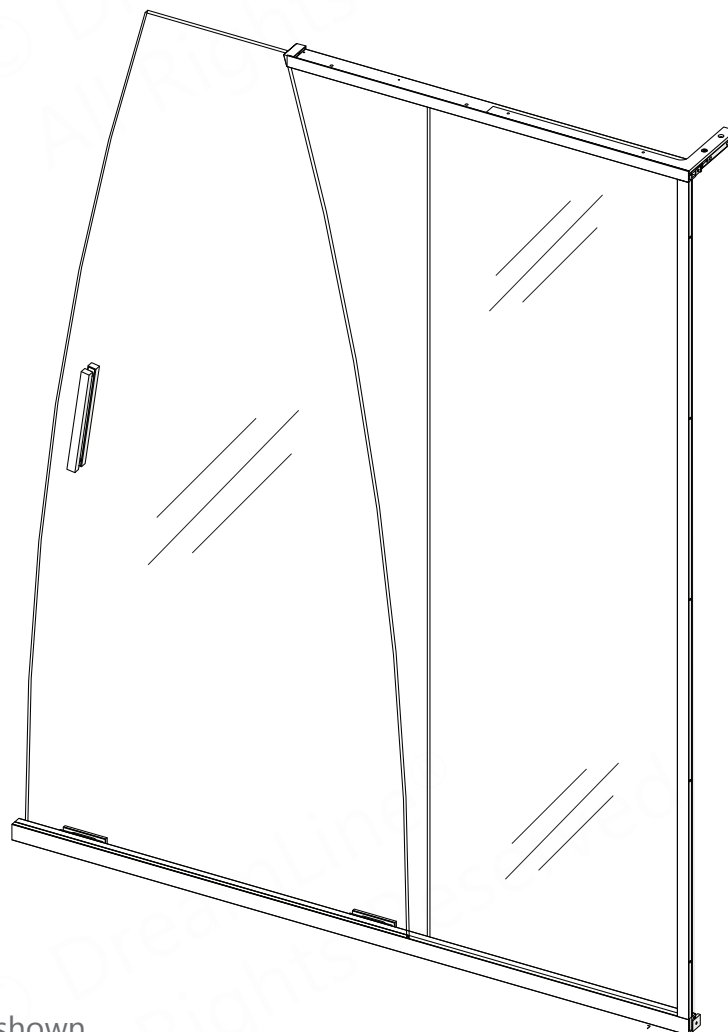

# CREST

## SHOWER DOOR INSTALLATION INSTRUCTIONS

PLEASE REVIEW THIS ENTIRE MANUAL PRIOR TO INSTALLATION



left-hand door installation shown

### MODEL #s

SHDR-1760760-##

SHDR-176076G-##

## = finish

01 - Chrome

04 - Brushed Nickel

06 - Oil Rubbed Bronze

09 - Satin Black

G - Gray Glass

### IMPORTANT!

DreamLine® reserves the right to alter, modify or redesign products at any time without prior notice for the purpose of product improvement and customer experience. Please refer to the model's web page on **DreamLine.com** for the latest technical drawings, installation manuals, warranty information or additional product details.

**Do Not Return Product to the Store. Contact DreamLine® with any questions**



### Questions?

Please Call DreamLine Customer Support: **1-866-731-2244**  
Hours of Operation M-F 8AM - 6PM EST

**Support@DreamLine.com**





**This model is treated with DreamLine’s exclusive ClearMax™ Glass technology. This is a specially formulated coating that prevents the build up of soap and water spots.**

**Install the surface with the ClearMax™ label towards the inside of the shower. Please note that depending on the model, the glass may be coated on either one or both surfaces.**

**For best results, squeegee the glass after each use and dry with a soft cloth.**

Record the following purchase information for your records or in the event you need to contact DreamLine®:

Purchase Order Number \_\_\_\_\_

Store/Vendor Purchased From \_\_\_\_\_

Installation Date \_\_\_\_\_

OD Number (optional) \_\_\_\_\_  
\*found on the shipping box or label if available.

Installed By: \_\_\_\_\_

SKU Number \_\_\_\_\_

# Table of Contents

Section Title	Page #
ClearMax™ Coating Information	—
Warnings and General Preparation	2
Model Specific Preparation	3
Tools	4
Detailed Diagram of Shower Door Components	5
Parts List	6-7
Installation Steps	8-32
Reversible 18" L-Bar™ and Top SafeStop™ Bumper Installation	22-24
Bottom SafeStop™ Bumpers Installation	25
Bottom Roller Assembly and Door Installation	27-29
Handle and Vinyl Installation	31
Reversible 18" L-Bar™ Feature	33
Product Maintenance	34
Troubleshooting	35
Factory Parts Information	36

## Symbol Legend

 **TIP** - for ease of installation.

 **NOTE** - take note of special feature; additional information.

 **REQUIRED** - requires special attention; signifies a warning.

 **CORRECT** - recommended.

 **INCORRECT** - not recommended.

Average Installation Time

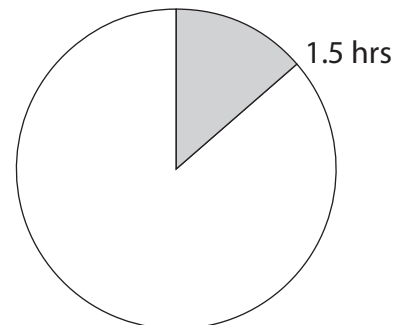



**IMPORTANT**

- DreamLine® reserves the right to alter, modify or redesign products any time without prior notice for product improvement and customer experience. Please refer to the model's web page on [DreamLine.com](http://DreamLine.com) for the latest technical drawings, installation manuals, warranty information or additional product details.
- This product should be installed by someone familiar with the construction requirements for this type of project and the care necessary for the safe installation and operation of the product.
- The safety of any installation is the responsibility of the installer.
- Professional installation recommended. *(All Models)*
- Professional installation required. *(Enigma Series)*
- To prevent damage or serious injury, Do Not lean against the installed panel/door/glass.
- To prevent damage or serious injury: Do Not attempt to lift or move a heavy lite of glass alone. Use an assistant and/or a professional grade glass suction cup.
- The installation of some models may require drilling down into the threshold. Contact the manufacturer of the base, tub, or threshold material with any questions regarding the drilling of holes into their product.
- All drawings in this installation manual are for illustrative purposes only and are not drawn to scale.

**TEMPERED GLASS WARNING**

- Your Shower Door Glass Could Shatter Without Warning if Improperly Installed or Mishandled
- Do Not install or operate a shower door if the glass has chipped corners, slivered edges or is otherwise damaged and/or has been dropped or banged into a hard surface such as tile, marble or glass.
- **The main causes of tempered glass breakage are:**
  - Improper handling, storage or installation
  - Misuse/abuse
  - Lack of maintenance
  - Failure to replace damaged glass
  - **Improper handling during storage, unpacking and installation:**
  - Corners and edges are the most susceptible area to damage on a lite of tempered glass and should be protected and handled with care during storage, unpacking, installation and operation. A concentrated point of pressure or impact with a surface harder than itself may cause the tempered glass to shatter. The tempered glass may release immediately, within several hours or even days later.
  - **Incorrect installation of door hardware, rollers, hinges, channels, stopper or glass:**
  - Improper installation may include: loose hardware and/or lack of proper gaskets between the hardware and glass. Additionally, improper alignment of guide rails, wall profiles or other hardware during installation or operation may place stress on the glass edges and cause it to break.
  - This product must be installed by a professional and experienced installer familiar with the safe handling of tempered glass.
  - **Improper use of this product:**
    - Aggressively opening or closing the door may cause trauma to the glass, which can lead to breakage. This may occur immediately or hours or even days later.
    - **The shower door hardware and glass should be inspected periodically:**
      - Instruct the homeowner how to perform a periodic inspection of the shower hardware and glass - some minor adjustments may be necessary based upon the use (or misuse) of the shower door. Ensure that the hardware remains tight and that the door alignment and operation are correct. Any adjustments should be made upon discovery to prevent damage to the product.
      - Additional considerations should be given to the installation of frameless tempered glass products in households with young children or an elderly person due to an increased chance of improper handling. In such cases, alternatives such as shower curtains or grab bars should be considered.

**GENERAL PREPARATION**

- After opening all boxes and packages, read this introduction carefully. Check that all the items are included in the package by marking off the components on the “**Detailed Diagram of Product Components**” page. Examine all boxes and packages for shipping damage. If the unit has been damaged, has a finishing defect, or is missing parts; please contact our Customer Support department within 3 business days of the delivery date. **Please note that DreamLine® will not replace any damaged products or missing parts free of charge after 3 business days or if the product has been installed.** Please contact DreamLine® if you have any questions.
- **Please note that you should refer to your local building codes with questions on installation compliance standards. Building and plumbing codes may vary by location, and DreamLine® is not responsible for code compliance standards for your project and will not accept any returns.**
- If this unit is going to be installed in a new construction, install all the required plumbing and drainage before installing the shower. **Use a competent and licensed (if required by local code) plumber for all plumbing installation.**
- Make sure that prior to beginning the installation, the surfaces are leveled and solid and will be able to support the total weight of the unit. Also make sure the walls are at right angles. Irregular installation surface level, radius corners or improper angle of side walls will result in serious problems for your installation. Please note that some adjustments and drilling will be necessary during the installation process.
- Protect all primary surfaces of the product during installation. Never set your glass down directly onto a tile floor. Leave corner protectors in place until it is necessary to remove them. Always use a piece of wood or cardboard to protect the bottom edge and corners of the glass prior to and during installation.
- This unit must be installed upon a finished threshold and against finished walls.
- *DreamLine® shower doors are not designed to be installed into a fiberglass surround due to the radius corners and lack of a solid surface to mount the hardware.*

**WARNING: TO AVOID THE RISK OF DAMAGE OR INJURY:**

- **Follow all recommendations and requirements as shown in the installation instructions.**
- Perform a thorough inspection of the glass and all parts for any damage prior to installation. Any damage to tempered glass can cause breakage.  
**Do Not install damaged glass!**
- Do Not install or operate a shower or tub door if the glass has chipped corners, slivered edges or is otherwise damaged. Do Not install or operate a shower or tub door that has been dropped or banged into a hard surface such as tile, marble or glass.
- **CAUTION:** Contact with any hard surface can damage tempered glass and cause it to shatter.
- This product uses tempered glass. Glass cannot be cut after it has been tempered.  
**Do Not attempt to cut tempered glass.**
- DreamLine® Glass Shower doors, Tub doors, Inline panels, and Return panels can shatter due to improper handling or lack of maintenance. Conduct periodic inspections of glass and all parts for possible damage, missing or loose parts.
- Always wear proper safety equipment such as: safety goggles, work gloves and appropriate footwear during the installation process.
- **WARNING. Risk of leakage and/or damage.** Follow all instructions regarding the application of silicone sealant or . Allow 24 hours for the sealant to cure before the initial use of the shower or tub product. Follow the silicone manufacturer’s recommendations regarding the use of their product.
- **Thoroughly read these instructions before installing or using this product.**
- **Leave this manual for the end-user of the product.**



This product should be installed by someone familiar with the construction requirements for this type of product and the care necessary for the safe installation and operation of the product.



# Model Specific Preparation

**! REQUIRED:**

**1/2" Out-of-Plumb Adjustment on the Panel side only. Verify threshold and walls with a level**

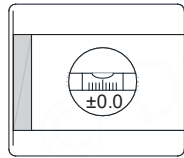
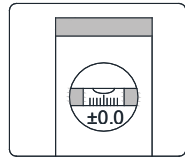

**Threshold must be level**

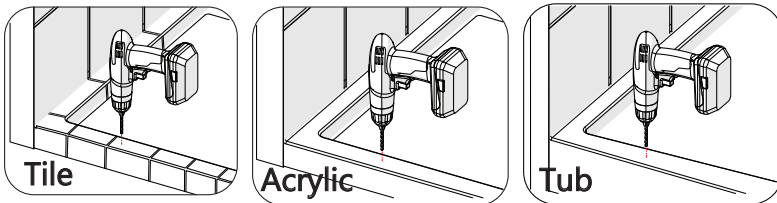
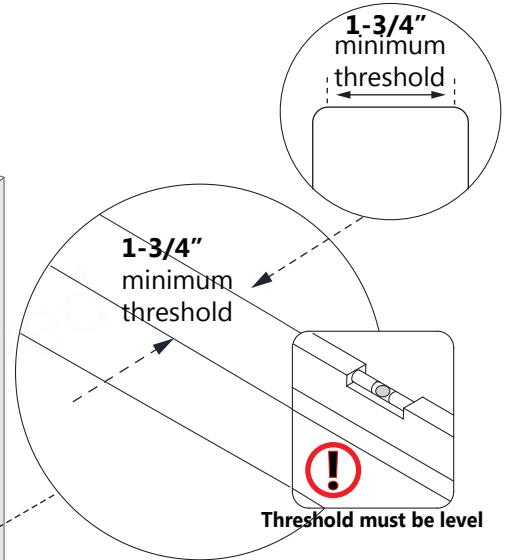
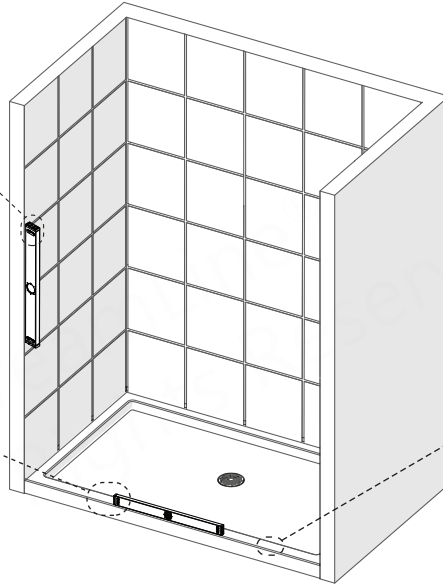

**TIP**

Contact the manufacturer of the base, tub or threshold material with any questions regarding the drilling of holes into their product.

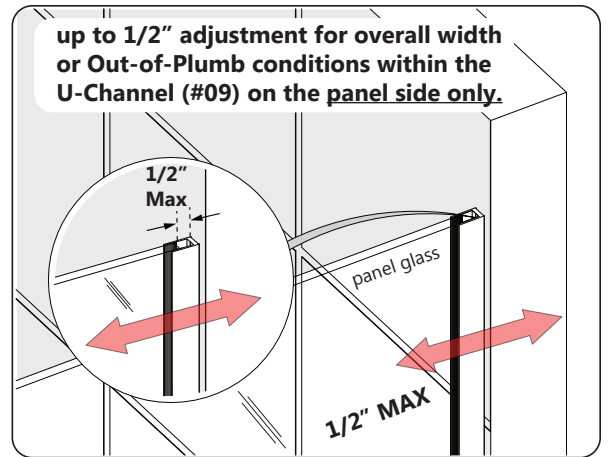

\*right-hand panel glass installation shown

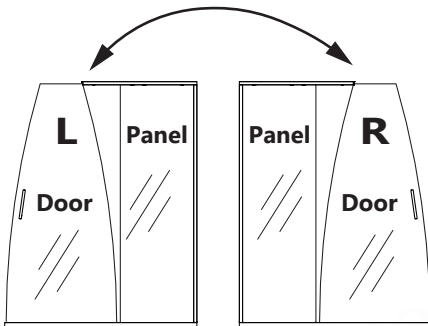

**TIP**

This model is reversible for right or left-hand door installation. The left-hand door installation is shown as an example throughout this manual. For the right-hand door installation, simply begin on the opposite wall and reverse the orientation of the steps shown.

**NOTE**

This manual will describe the shower door installation using the Reversible L-Bar™ in the right-handed orientation (shown above). To reverse the L-Bar™ orientation please refer to page 33.

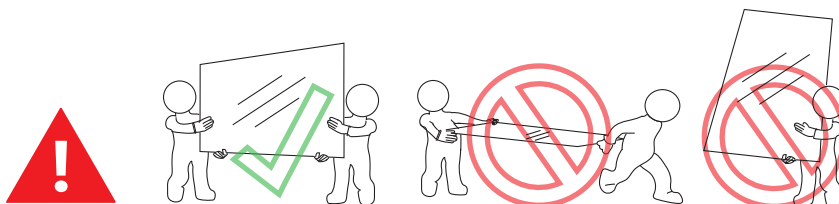

**This door recommends professional installation. Two installers recommended.**

## Product Maintenance

**BASES and BACKWALLS:** To ensure long lasting life for your acrylic back walls: wipe them off after each use with a soft cloth. To clean the acrylic back walls use non-abrasive sprays or cream based cleaners. Avoid the use of aerosol spray cleaners. Never use abrasive cleansers, metal brushes or scrapers that could permanently scratch or dull the surface.

**GLASS:** To ensure long lasting life for your glass shower products: wipe them off after each use with a soft cloth. Rinse and wipe off the glass using either a soft cloth or a squeegee to prevent soap buildup and water spots (Hard water can etch the surface of the glass over time if left to dry). To prevent scratching the surface: never use abrasive cleaners or cleaning products that contain scouring agents. Never use bristle brushes or abrasive sponges that may scratch the surface of the glass.

**HARDWARE:** To ensure a long lasting finish: wipe off all metal parts after each use with a soft cloth. Do not use abrasive cleaners or cleaning products containing ammonia, bleach or acid. If accidentally used, rinse the surface as soon as possible to prevent damage to the finish (peeling or corrosion). After cleaning the polished finishes, rinse thoroughly and wipe dry with a soft clean-cloth.

Clean stainless steel surfaces at least once a week. When applying stainless steel cleaner or polish to stainless steel hardware, work with the grain (not across the grain). Never use an abrasive sponge or cloth, steel wool or wired brush as these may permanently scratch the surfaces.



**To maximize the life of your door, it is important to regularly inspect the glass and other hardware for misalignment, proper attachment, and/or damage. Contact DreamLine® with any questions or concerns.**

### CREST Maintenance Checklist

- Check that the unit is stable, operates smoothly and that the installation is secure.
- Bottom Profile** level and tight to the threshold
- U-Channel** plumb and tight to the wall
  - Panel Glass** secured within the U-Channel
- SafeStop™ Bumpers** (top/bottom) secured to the wall
- L-Bar™** and **Top Profile Assembly** level and secured to the Panel Glass and wall
  - All screws are tight
  - Top Profile End Cap** secured to the end of the **Top Profile**
- PVC Glass Spacer 1mm** present between the Panel Glass and the end of the **Bottom Profile Insert** to prevent glass-to-metal contact
- Bottom Roller Assemblies** secured tightly to the **Door Glass**
  - All bolts are tight
  - If applicable, **Shims** are tightly secured within gap between **Door Glass** notch and **Roller Assemblies**
- Handle** is tightly secured to the Door Glass
- Remove **Vinyl Seal** to inspect the edge of the Door Glass for concealed damage
  - Damaged glass must be replaced!**
- Replace damaged or missing vinyl seals
- Inspect and replace silicone as necessary to prevent leakage

# Troubleshooting

Problem/Symptom	Suggested Solution	Page(s)
Missing Parts	<ul style="list-style-type: none"> <li>•Check all shipping/packaging material for missing parts/components.</li> <li>•If not found, contact DreamLine Customer Support [1-866-731-2244] to order factory part replacement.</li> </ul>	—
<b>Bottom Profile (#06)</b> was cut too short or was cut from the wrong end during installation.	<ul style="list-style-type: none"> <li>•Contact DreamLine Customer Support [1-866-731-2244] to order factory part replacement.</li> </ul>	—
Leakage: <b>Bottom Profile (#06)</b>	<ul style="list-style-type: none"> <li>•Confirm that silicone was properly applied along the entire length of the bottom rail.</li> <li>•Confirm that the <b>Bottom Channel Insert (#12)</b> is installed correctly [see Step 19]</li> <li>•Direct the shower head/water flow away from the area.</li> <li>•Insufficient silicone application under the <b>Bottom Profile (#06)</b>. [see Step 6]</li> </ul>	13;26
Leakage: between the <b>Door (#11)</b> and <b>Panel Glass (#10)</b>	<ul style="list-style-type: none"> <li>•<b>Vinyl Seal (#23)</b> is missing, broken, or cut too short [see Step 24]</li> </ul>	31
<b>Door Glass (#11)</b> experiences grinding or scraping during use/or operation.	<ul style="list-style-type: none"> <li>•Check that the <b>Bottom Roller Assemblies (#22)</b> are installed properly onto the <b>Door Glass (#11)</b> and sit squarely in the <b>Bottom Profile (#03)</b>. [see Step 21]</li> </ul>	28
<b>Door Glass (#11)</b> is opening or closing on its own	<ul style="list-style-type: none"> <li>•Threshold is out of level. Removal and re-installation may be necessary.</li> </ul>	
<b>Door Glass (#11)</b> makes direct contact with the wall	<ul style="list-style-type: none"> <li>•<b>SafeStop™ Bumpers (top/bottom)</b> are not installed.</li> <li>•<b>SafeStop™ Bumper (top/bottom)</b> is not correctly aligned with the glass</li> </ul>	22-25
<b>Door Glass (#11)</b> has excessive play in the <b>Top Profile(#01)</b>	<ul style="list-style-type: none"> <li>•<b>Guide Rail Inserts (#05)</b> missing or broken.</li> <li>•Door Glass sits too low within the <b>Top Profile (#01)</b>. Add the appropriate spacers.</li> </ul>	29
<b>Door Glass (#11)</b> sits too high or too low within the <b>Top Profile(#01)</b>	<ul style="list-style-type: none"> <li>•Incorrect application of <b>1mm/2mm Shims (#24)</b> into the <b>Door Glass (#11)</b> [see Step 22]</li> <li>•<b>Top Profile (#01)</b> is not fully seated on the <b>Panel Glass(#10)</b> [see Steps 16-17]</li> </ul>	23-24;29
<b>Top Profile (#01)</b> is loosely mounted on the <b>Panel Glass (#10)</b>	<ul style="list-style-type: none"> <li>•Insufficient silicone application</li> <li>•Silicone not fully cured</li> <li>•<b>U-Channel (#09)</b> is too long. [see Steps 15-17]</li> </ul>	22-24
<b>Bottom Roller Assembly (#22)</b> are loosely mounted on the <b>Door Glass (#11)</b> .	<ul style="list-style-type: none"> <li>•Make sure all Roller bolts are tightened [see Fig 21]</li> <li>•Confirm the vinyl gasket on the <b>Bottom Roller Assembly (#22)</b> is present.</li> </ul>	28
<b>L-Bar™ Support Bracket (#02)</b> not installed level with the panel glass.	<ul style="list-style-type: none"> <li>•Review the <b>L-Bar™ (#02)</b> and <b>Top Profile (#01)</b> installation steps</li> <li>•Removal and re-installation may be necessary.</li> <li>•The <b>L-Bar™</b> must be installed correctly for the safety of the installation.</li> </ul>	22-24
<b>Door Glass (#11)</b> does not slide smoothly through the <b>Guide Rail Inserts (#05)</b> during operation	<ul style="list-style-type: none"> <li>•Loosen the <b>L-Bar™ M6 x18 Flat Head screws (#02.4)</b> and use the <b>L-Bar™ M5x8 set screws (#02.6)</b> to adjust the angle of the L-Bar. Tighten the <b>L-Bar™ M6x18 Flat Head Screws (#02.4)</b> to fix the position. Test operation of the door.</li> </ul>	22-24



Prior to contacting DreamLine® Customer Service, please have the following information readily available:

- Purchase Order Information
  - Name, PO Number, Dealer/Vendor Name, etc.
- SKU/Model Number (see Pages 36-37)
- Factory Part Information (see Pages 36-37)



## Factory Parts Information

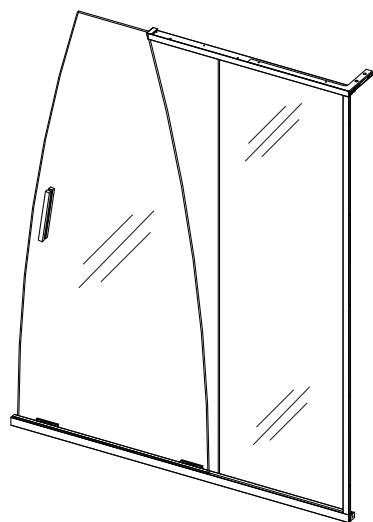

**BOLD** digit indicates finish color:

**1** = Chrome

**4** = Brushed Nickel

**6** = Oil Rubbed Bronze

**9** = Satin Black

CREST 60x72 SHDR-1760760-##		FACTORY PARTS INFORMATION	
ITEM #	FACTORY PART NUMBER	ITEM DESCRIPTION	QTY
01	042360 <b>1</b> 1-0904 / 042360 <b>4</b> 1-0904 042360 <b>6</b> 1-0904 / 042360 <b>9</b> 1-0904	Top Profile for 10mm (3/8in) Glass	1 pc
02	0712 <b>1</b> 152 / 0712 <b>4</b> 152 0712 <b>6</b> 152 / 0712 <b>9</b> 152	L-Bar Support Bracket Reversible 18in for 10mm (3/8in) Glass	1 pc
03	095205	M5 Hex Head Screw	2pcs
04	0755 <b>1</b> 136 / 0755 <b>4</b> 136 0755 <b>6</b> 136 / 0755 <b>9</b> 136	Decorative Screw Cap	4 pcs
05	07550133	Guide Rail Insert (pre-installed into Top Profile)	4 pcs
06	042370 <b>1</b> 1-1524 / 042370 <b>4</b> 1-1524 042370 <b>6</b> 1-1524 / 042370 <b>9</b> 1-1524	Bottom Profile	1 pc
07	092108	ST4.2x40mm Countersunk Screw	9 pcs
08	07552148	Wall Anchor 8mm (5/16in)	3 pcs
09	041540 <b>1</b> 1-1930 / 041540 <b>4</b> 1-1930 041540 <b>6</b> 1-1930 / 041540 <b>9</b> 1-1930	U-Channel 1" Aluminum for 10mm (3/8in) Glass	1 pc
10	1003600 <b>1</b>	Inline Panel Glass (Clear)	1 pc
11	1003600 <b>2</b>	Door Glass (Clear)	1 pc
12	07550134	PVC Glass Spacer 1mm	1 pc
13	0702 <b>1</b> 191 / 0702 <b>4</b> 191 0702 <b>6</b> 191 / 0702 <b>9</b> 191	SafeStop™ Bumper Plate (Top)	1 pc
14	07050135	SafeStop™ Bumper PVC insert w/Adhesive (Top)	1 pc
15	0702 <b>1</b> 193 / 0702 <b>4</b> 193 0702 <b>6</b> 193 / 0702 <b>9</b> 193	SafeStop™ Bumper Plate (Bottom)	2 pcs
16	07050132	SafeStop™ Bumper PVC insert w/Adhesive (Bottom)	2 pcs
17	094214	M4x6mm Countersunk Hex Head Screw	4 pcs
18	042380 <b>1</b> 1-887 / 042380 <b>4</b> 1-887 042380 <b>6</b> 1-887 / 042380 <b>9</b> 1-887	Bottom Profile Insert	1 pc
19	092105	ST4.2x25 Countersunk Screw	3 pcs
20	0722 <b>1</b> 089 / 0722 <b>4</b> 089 0722 <b>6</b> 089 / 0722 <b>9</b> 089	Back-to-Back Rectangular Slide Handle	1 pc
21a	07551137	Top Profile End Cap, Right	1 pc
21b	07551144	Top Profile End Cap, Left	1 pc
22	0732 <b>1</b> 031 / 0732 <b>4</b> 031 0732 <b>6</b> 031 / 0732 <b>9</b> 031	Bottom Roller Assembly for 10mm (3/8in) Glass	2 pcs
23	063004100-1886	Vinyl Seal with a Flexible Fin for 10mm (3/8in) Glass	1 pc
24a	07550152	PVC Spacer 1mm for Bottom Roller	2 pcs
24b	07550153	PVC Spacer 2mm for Bottom Roller	2 pcs

Contact [Support@DreamLine.com](mailto:Support@DreamLine.com) for Part replacement, installation assistance or additional information.

Complete **Warranty** information is available on [DreamLine.com](http://DreamLine.com).



## Factory Parts Information

CREST 60×72 SHDR-176076G-##		FACTORY PARTS INFORMATION	
ITEM #	FACTORY PART NUMBER	ITEM DESCRIPTION	QTY
01	042360 <b>9</b> 1-0904PF	Top Profile for 10mm (3/8in) Glass	1 pc
02	0712 <b>9</b> 152	L-Bar Support Bracket Reversible 18in for 10mm (3/8in) Glass	1 pc
03	095205	SCREW, SH, M5	2 pcs
04	0755 <b>9</b> 136	Decorative Screw Cap	4 pcs
05	07550133	Guide Rail Insert (pre-installed into Top Profile)	4 pcs
06	042370 <b>9</b> 1-1524PF	Bottom Profile	1 pc
07	092108	ST4.2×40mm Countersunk Screw	9 pcs
08	07552148	Wall Anchor 8mm (5/16in)	3 pcs
09	041540 <b>9</b> 1-1930PF	U-Channel 1" Aluminum for 10mm (3/8in) Glass	1 pc
10	1003600 <b>3</b>	Inline Panel Glass (Gray)	1 pc
11	1003600 <b>4</b>	Door Glass (Gray)	1 pc
12	07550134	PVC Glass Spacer 1mm	1 pc
13	0702 <b>9</b> 191	SafeStop™ Bumper Plate (Top)	1 pc
14	07050135	SafeStop™ Bumper PVC insert w/Adhesive (Top)	1 pc
15	0702 <b>9</b> 193	SafeStop™ Bumper Plate (Bottom)	2 pcs
16	07050132	SafeStop™ Bumper PVC insert w/Adhesive (Bottom)	2 pcs
17	094214	M4x6mm Countersunk Hex Head Screw	4 pcs
18	042380 <b>9</b> 1-0887PF	Bottom Profile Insert	1 pc
19	092105	ST4.2×25 Countersunk Screw	3 pcs
20	0722 <b>9</b> 089	Back-to-Back Rectangular Slide Handle	1 pc
21a	07551137	Top Profile End Cap, Right	1 pc
21b	07551144	Top Profile End Cap, Left	1 pc
22	0732 <b>9</b> 031	Bottom Roller Assembly for 10mm (3/8in) Glass	2 pcs
23	063004100-1886	Vinyl Seal with a Flexible Fin for 10mm (3/8in) Glass	1 pc
24a	07550152	PVC Spacer 1mm for Bottom Roller	2 pcs
24b	07550153	PVC Spacer 2mm for Bottom Roller	2 pcs

**BOLD** digit indicates finish color: **9** = Satin Black

Contact [Support@DreamLine.com](mailto:Support@DreamLine.com) for Part replacement, installation assistance or additional information.

Complete **Warranty** information is available on [DreamLine.com](http://DreamLine.com).



---

---

TEL: 866-731-2244  
FAX: 866-857-3638  
DREAMLINE.COM



For more information on DreamLine® Shower Doors and Enclosures please visit **DreamLine.com**