



Advanced Heating
& Hot Water Systems

Elite
Premier

www.htproducts.com

10 : 1
Turndown
Ratio

Up to
96%
Efficient
Gas Fired
Boiler

Eliminates the
Need for Primary/
Secondary Piping



Impressive range: 7 models, ranging from 80,000 to 399,000 Btuh

Elite

Premier

10:1
Turndown
Ratio



LOW MASS

Up to 96% Efficient

Vents in inexpensive,
easy-to-install PVC pipe,
up to 200 combined feet

State of the art control
interface: a 2 line 20 character
LCD control interface:
Total System Control

Impressive range:
7 models, ranging from
80,000 to 399,000 Btuh

Floor standing or wall mount

12 year limited warranty

316 L Stainless Steel Heat Exchanger

Power Button

State of the art control interface: a 2 line 20 character LCD control interface: Total System Control



Water Pressure & Switch Thermistor

316L Stainless Steel Heat Exchanger

Spark Electrode

Burner

Air Channel

Flame Rectification Probe / Electrode

Blower Motor

Air / Gas Mixer

Gas Valve

928 Control Board

Customer Control Board



Elite Premier Applications: Radiant Floor • Fan Coil • Base Board • Snow Melt • DHW (w/ Indirect Tank or VWH) • Pool Heater (w/ Indirect Tank) • ASME

1 EXHAUST VENT CONNECTION

2 COMBUSTION AIR INLET CONNECTION

3 ELECTRICAL CONNECTIONS

4 SYSTEM RETURN

5 SYSTEM SUPPLY WITH INTEGRATED RELIEF VALVE

6 CONDENSATE CONNECTION

7 GAS LINE CONNECTION

8 DISPLAY/CONTROL PANEL

9 AIR RELEASE VENT

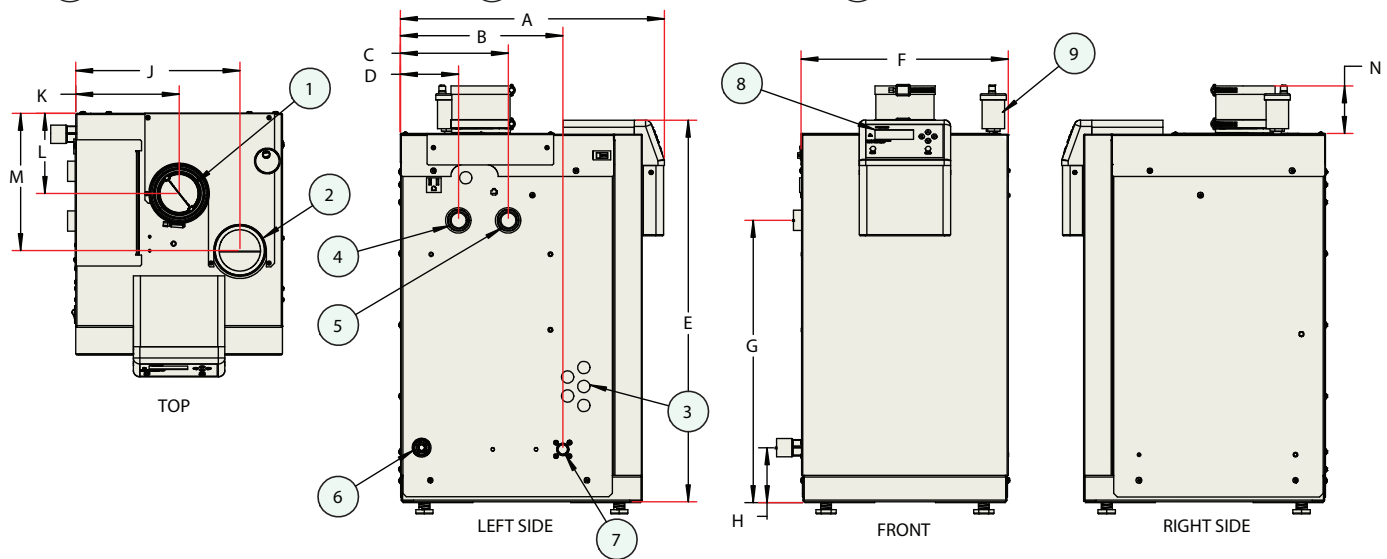

MODEL*	A	B	C	D	E	F	G	H	J	K	L	M	N	Shipping Weight
EP-80	18.5"	11.5"	7.75"	4.25"	27"	14.5"	20"	4"	11.75"	7.38"	5.75"	9.75"	4"	108 lbs
EP-110	18.5"	11.5"	7.75"	4.25"	27"	14.5"	20"	4"	11.75"	7.38"	5.75"	9.75"	4"	113 lbs
EP-150	19.5"	12.5"	10.25"	2.50"	27"	14.5"	20"	3.75"	11.75"	7.38"	4.25"	8.25"	4"	126 lbs
EP-220	26.5"	19.5"	15.50"	6.00"	24.25"	14.5"	20"	4.5"	11.75"	7.38"	4.25"	8.25"	4"	164 lbs

1 EXHAUST VENT CONNECTION

2 COMBUSTION AIR INLET CONNECTION

3 ELECTRICAL CONNECTIONS

4 SYSTEM RETURN

5 RELIEF VALVE

6 CONDENSATE CONNECTION

7 CONDENSATE CONNECTION

8 GAS LINE CONNECTION

9 DISPLAY/CONTROL PANEL

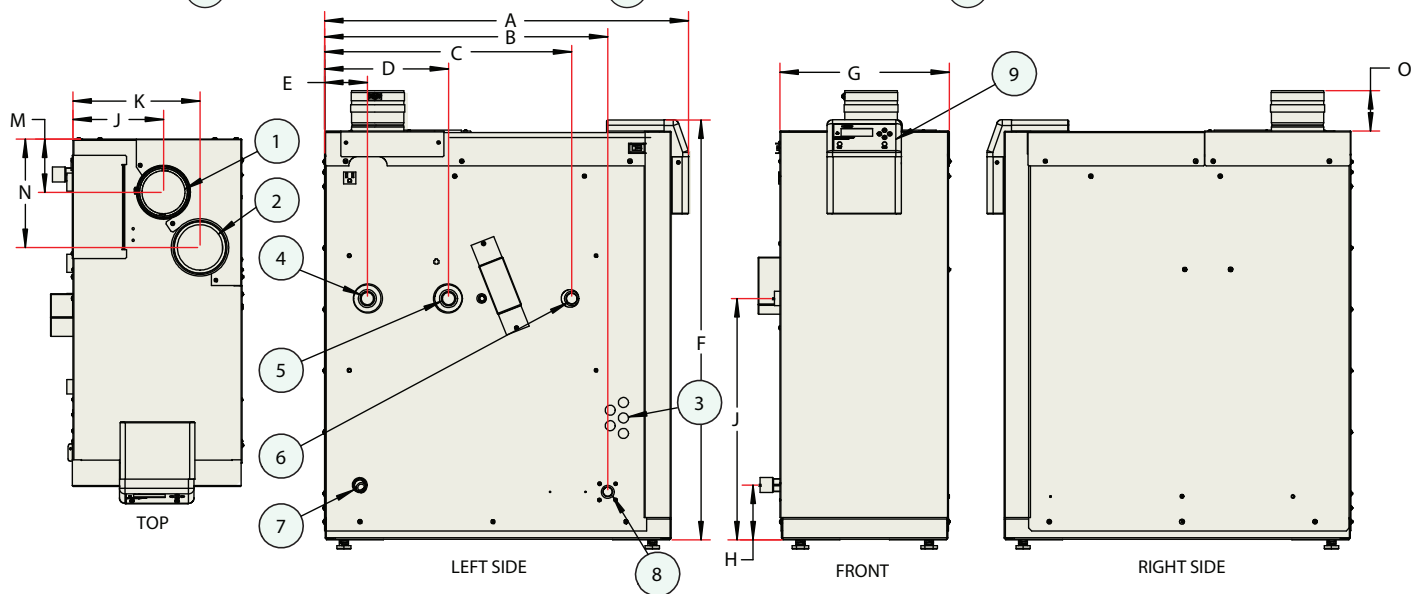

MODEL*	A	B	C	D	E	F	G	H	J	K	L	M	N	O	Shipping Weight
EP-299	24.75"	17.5"	14.5"	7.38"	3.25"	36.5"	14.5"	4.75"	21"	11"	7.88"	4.63"	9.5"	3.5"	211 lbs
EP-301	24.75"	17.5"	14.5"	7.38"	3.25"	36.5"	14.5"	4.75"	21"	11"	7.88"	4.63"	9.5"	3.5"	211 lbs
EP-399	31.75"	24.75"	21.5"	10.75"	3.75"	36"	14.5"	4.75"	21"	11"	7.88"	4.63"	9.5"	3.5"	256 lbs

Model	Btuh /Input Range	Net Ratings (Water)	DOE Heating	AFUE	Supply/Return	Exhaust /Air inlet	Gas Connection
EP-80	8,000 - 80,000	-	7,700-77,000	96.4	1"	3"	3/4"
EP-110	11,000 - 110,000	-	10,600-106,000	96.4			
EP-150	15,000 - 150,000	-	14,300-143,000	95.4			
EP-220	22,000 - 220,000	-	20,900-209,000	95.2			
EP-299	30,000 - 299,000	-	27,400-283,000	94.5	1-1/4"	4"	1"
EP-301	30,000 - 301,000	251 Mbh	28,300-289,000	96.1**			
EP-399	40,000 - 399,000	335 Mbh	37,600-385,000	96.5**			

*"N" Denotes Natural Gas & "LP" Denotes Propane **Thermal Efficiency (Not AFUE) - All weights & dimensions in this brochure are approximate. In accordance with our company policy of ongoing product improvement, HTP Comfort Solutions LLC. reserves the right to make changes without prior notice.