

## Contents

Important User Information .....	2
Before Installation .....	2
Safety Precautions .....	3
Required Tools .....	3
Fastener Parts List .....	4
Wall Fasteners - Not Supplied .....	5
Layout Configurations .....	5
Locker Options .....	7
Wall Mount Configuration Locker Components .....	8
Island Mount Configuration Locker Components .....	9
Installation .....	10
Unpacking .....	10
Leveling .....	11
Connect All Locker Sides Together .....	14
Connect Locker Backs Together .....	16
Secure Lockers to Back Wall .....	17
Secure Island Mount Lockers .....	18
End Cover Panel Option .....	19
Assembly .....	19
Single End Cover Attachment .....	20
Island End Cover Attachment .....	21
Helmet & Shoulder Pad Holder Accessory Installation .....	22
Finalize Installation .....	23
Care and Maintenance .....	23
Replacement Parts .....	24

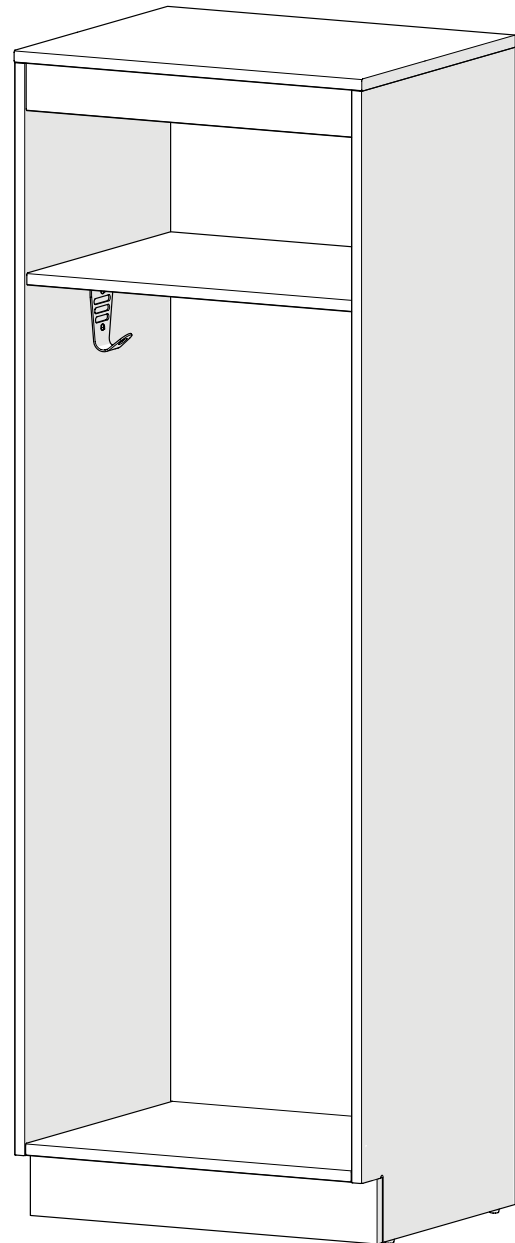

Visit the GearBoss Rival Athletic Lockers web page at [gearboss.com](http://gearboss.com) for more information.

**Note:** Please read and understand these instructions before starting the installation.

**Note:** If you need additional information, contact Wenger Corporation using the information below.

# **Important User Information**

---

## **General**

Copyright © 2021 by Wenger Corporation

All rights reserved. No part of the contents of this manual may be reproduced, copied, or transmitted in any form or by any means including graphic, electronic, or mechanical methods or photocopying, recording, or information storage and retrieval systems without the written permission of the publisher, unless it is for the purchaser's personal use.

Printed and bound in the United States of America.

The information in this manual is subject to change without notice and does not represent a commitment on the part of Wenger Corporation. Wenger Corporation does not assume any responsibility for any errors that may appear in this manual.

In no event will Wenger Corporation be liable for technical or editorial omissions made herein, nor for direct, indirect, special, incidental, or consequential damages resulting from the use or defect of this manual.

The information in this document is not intended to cover all possible conditions and situations that might occur. The end user must exercise caution and common sense when assembling or installing Wenger Corporation products. If any questions or problems arise, call Wenger Corporation at 1-800-887-7145.

## **Manufacturer**

The GearBoss Rival™ Athletic Locker is manufactured by:

Wenger Corporation  
555 Park Drive  
Owatonna, MN 55060  
(800) 4WENGER (493-6437) • +1 (507) 455-4100  
www.wengercorp.com

## **Intended Use**

- This product is intended for indoor use in normal ambient temperature and humidity conditions — it must not be exposed to outside weather conditions.
- This product is intended to be installed only as described in these instructions.

## **Warranty**

This product is guaranteed free of defects in materials and workmanship for five full years from date of shipment. A full warranty statement is available upon request.

# **Before Installation**

---

## **Overview**

- This system should be installed only by skilled technical persons, and only after carefully studying these instructions.
- It is suggested that the lockers are setup in a space that is large enough to safely handle the cartons, parts and accessories.
- Inspect the condition of the wall and floor where the lockers will be located. If the wall is not straight, establish a reference line so that the fronts of all lockers will line up. Also, determine the highest point on the floor, which will establish the leveled height of each row of lockers.

## **Before You Begin**

- Read the complete installation procedure before beginning.
- Hardware packs may contain extra fasteners that will not be required on your lockers.
- At least two people are required to install the locker.

## **Installation Requirements**

- Lockers should be installed on an unfinished floor, tile or epoxy coated concrete flooring.
  - Any additional floor coverings are to be installed after the lockers to avoid interference with the floor levelers.
-

# Safety Precautions

---

Throughout this document you may find cautions and warnings which are defined as follows:

- **WARNING:** Failure to follow the instruction could result in serious injury or damage to property.
- **CAUTION:** Failure to follow the instruction could result in minor injury or damage to property.

Read all of these safety instructions before installation.

<b>⚠ CAUTION</b>
<i>Make sure anyone installing the lockers has read and understands these instructions.</i>

<b>⚠ CAUTION</b>
<i>Failure to comply with Warnings and Cautions in this document can result in damage to property or serious injury.</i>

<b>⚠ CAUTION</b>
<i>To avoid damage and injury, more than one person is needed for installation.</i>

<b>⚠ CAUTION</b>
<i>Make sure the lockers are securely attached to walls or adjoining lockers after installation is complete.</i>

<b>⚠ CAUTION</b>
<i>Always wear safety glasses and gloves when assembling or installing the lockers.</i>

<b>⚠ CAUTION</b>
<i>Assemble and install the lockers only on flat, solid surfaces.</i>

## Required Tools

---

- Power drill
- 1/4" Socket or insert bit (to adjust levelers)
- 5/32" Hex key or insert bit (to remove bottom shelf)
- 3/16" Hex key or insert bit (to connect lockers and attach end cover panel)
- Phillips screwdriver or insert bit (if attaching end cover panel)
- Box cutter
- Tape measure
- Carpenter's level
- 5/32" Drill bit (if attaching end cover panel)
- Hammer or mallet (if attaching end cover panel)
- Hammer drill and bits (if anchoring to concrete)
- 9/16" Open end wrench (if installing helmet and shoulder pad topper)

# Fastener Parts List

---

## Locker Connection Fasteners\*

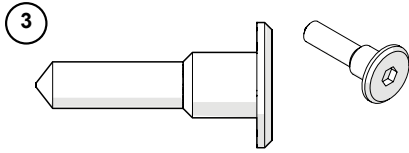

1/4-20 x 1.181"  
Connector Bolt

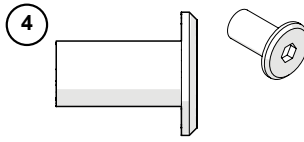

1/4-20  
Cap Nut

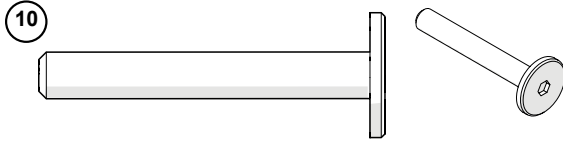

1/4-20 x 1.77"  
Machine Screw

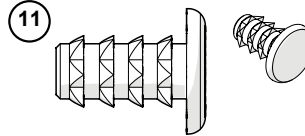

1/4-20  
Insert Nut

## Wall or Floor Bracket Fasteners\*

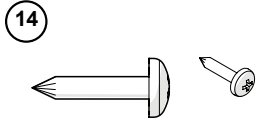

#8 x 5/8"  
Pan Head Screw

## End Cover Panel Accessory Fasteners\*

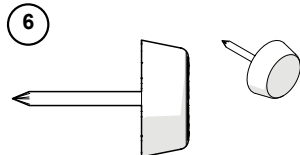

Tack Glide

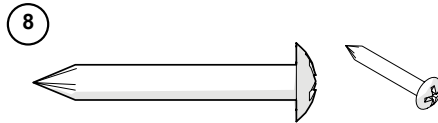

#8 x 1-1/4"  
Truss Head Screw

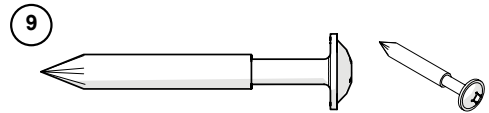

#8 x 1-3/8"  
Wood Screw

## Helmet & Shoulder Pad Holder Accessory Fasteners\*

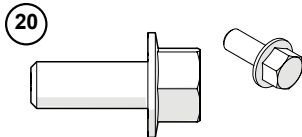

3/8-16 x 3/4"  
Flange Bolt

---

\*Depending on configuration, not all fasteners may be used.

## **Fasteners - Not Supplied**

---

Because materials and construction of floors and walls can vary, fasteners for attaching the locker to the structure are not provided. The installer must choose the appropriate fastener and follow the manufacturer's instructions.

### **⚠ WARNING**

***Inferior or improperly installed fasteners could cause the lockers to tip over.***

Determine the construction of the walls and/or floor.

If the lockers will be attached to the wall, no attachment to the floor is required.

If the lockers will be installed back-to-back in the middle of a room, attachment to the floor is required.

#### **Locker Fastener Guidelines:**

- If the floor is wood construction, attachment should be by sheet metal or lag screws (#10 minimum).
- If the floor is concrete, attachment should be by concrete screw (Tapcon), or sheet metal screws (#10 minimum) into metal or plastic inserts.
- If the wall is wood stud-and-drywall construction, attachment should be by lag screws (1/4" minimum) into every stud.
- If the wall is metal stud-and-drywall construction, attachment should be by toggle bolt (1/4" minimum) into every stud.
- If the wall is concrete block construction, attachment should be by concrete screw (Tapcon) or toggle bolt (1/4" minimum), spaced no more than 16" apart.
- If the wall is poured concrete construction, attachment should be by concrete screw (Tapcon) or wedge-type concrete anchors, spaced no more than 24" apart.

**Note:** Each wall and floor connection must be rated for a minimum of 500 lb of tension. Other fasteners may be used if the connection strength requirement is met.

## **Layout Configurations**

---

Lockers can be installed in wall mount or island mount configurations.

Be sure to follow the appropriate installation instructions on the following pages.

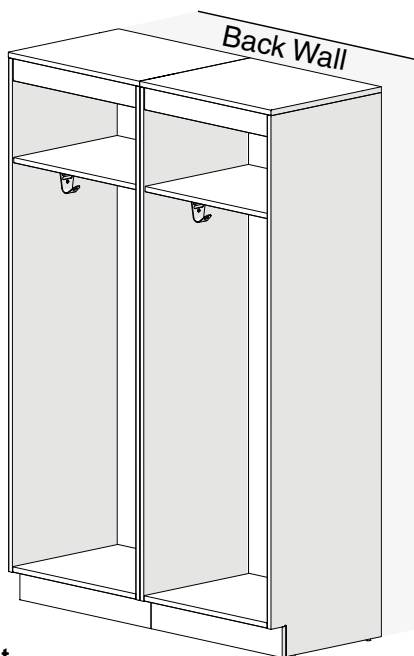

**Wall Mount Configuration**

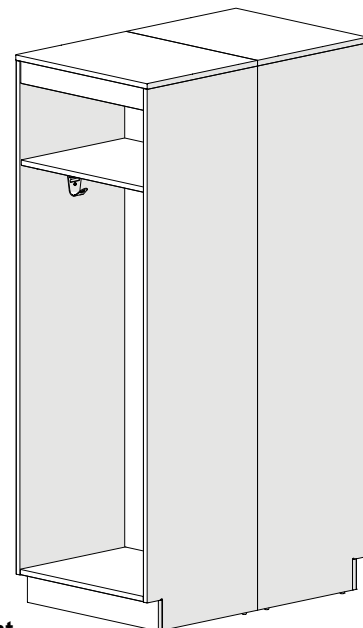

**Island Mount Configuration**

# Locker Options

---

## Customer Installed Options

The following options are installed during the locker installation.

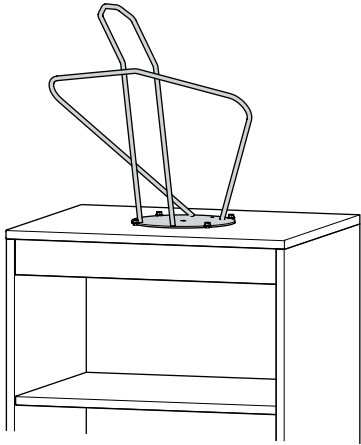

**Helmet & Shoulder Pad Holder  
Accessory**  
(see page 22)

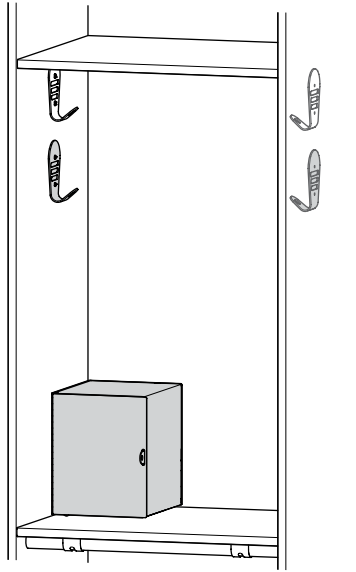

**ADA Compliant Locker**  
Includes two additional Garment Hooks  
(see separate installation instructions)

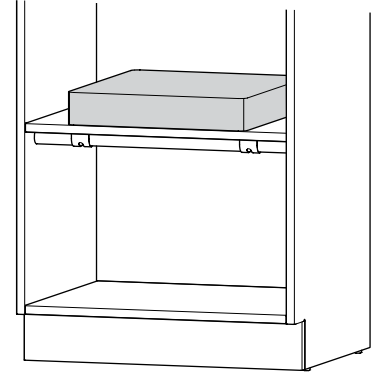

**Padded Seat Cushion**  
Available for  
Fixed or Hinged Seats  
(see separate installation instructions)

# Locker Options (continued)

---

## Pre-Installed Options

The following options may be installed on the locker prior to shipping with no assembly required.

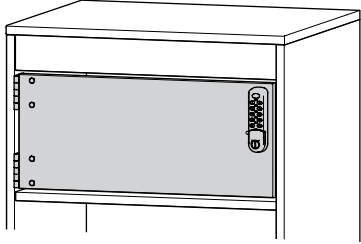

**Cubby Compartment with Programmable Digital Lock**

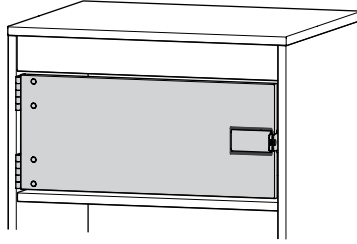

**Cubby Compartment with Hasp Lock**

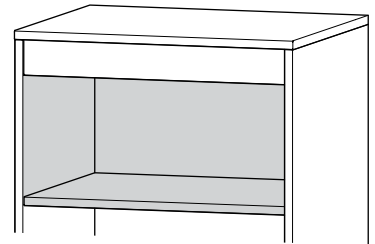

**Cubby Compartment with No Door**

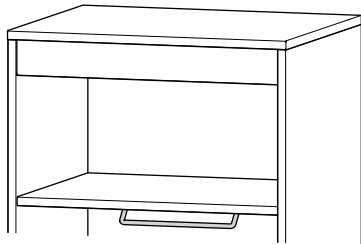

**Flip-down Garment Bar**

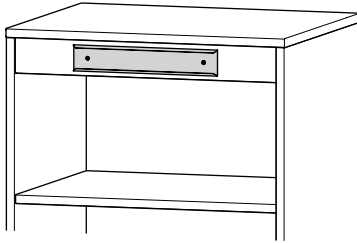

**Nameplate Housing**

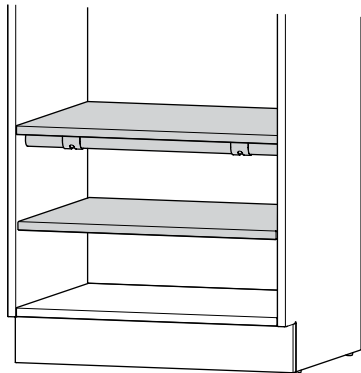

**Fixed Seat with Open Foot Locker  
Shelf is available for Open Foot Locker**

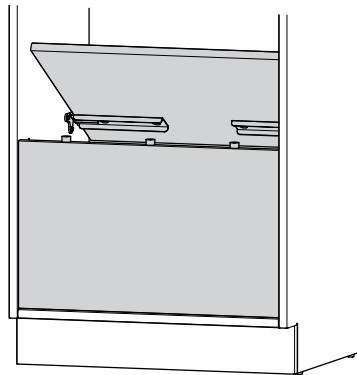

**Hinged Seat with Enclosed Foot Locker**

# Wall Mount Configuration Locker Components

Item	Description	Item	Description	Item	Description
1	Locker Unit	5	Single End Cover Panel (Optional)	9	#8 x 1-3/8" Wood Screw
2	Leveler	6	Tack Glide	13	Connector Bracket
3	1/4-20 x 1.181" Connector Bolt	7	Toe Kick Cover Plate	14	#8 x 5/8" Pan Head Screw
4	1/4-20 Cap Nut	8	#8-15 x 1-1/4" Truss Head Screw		

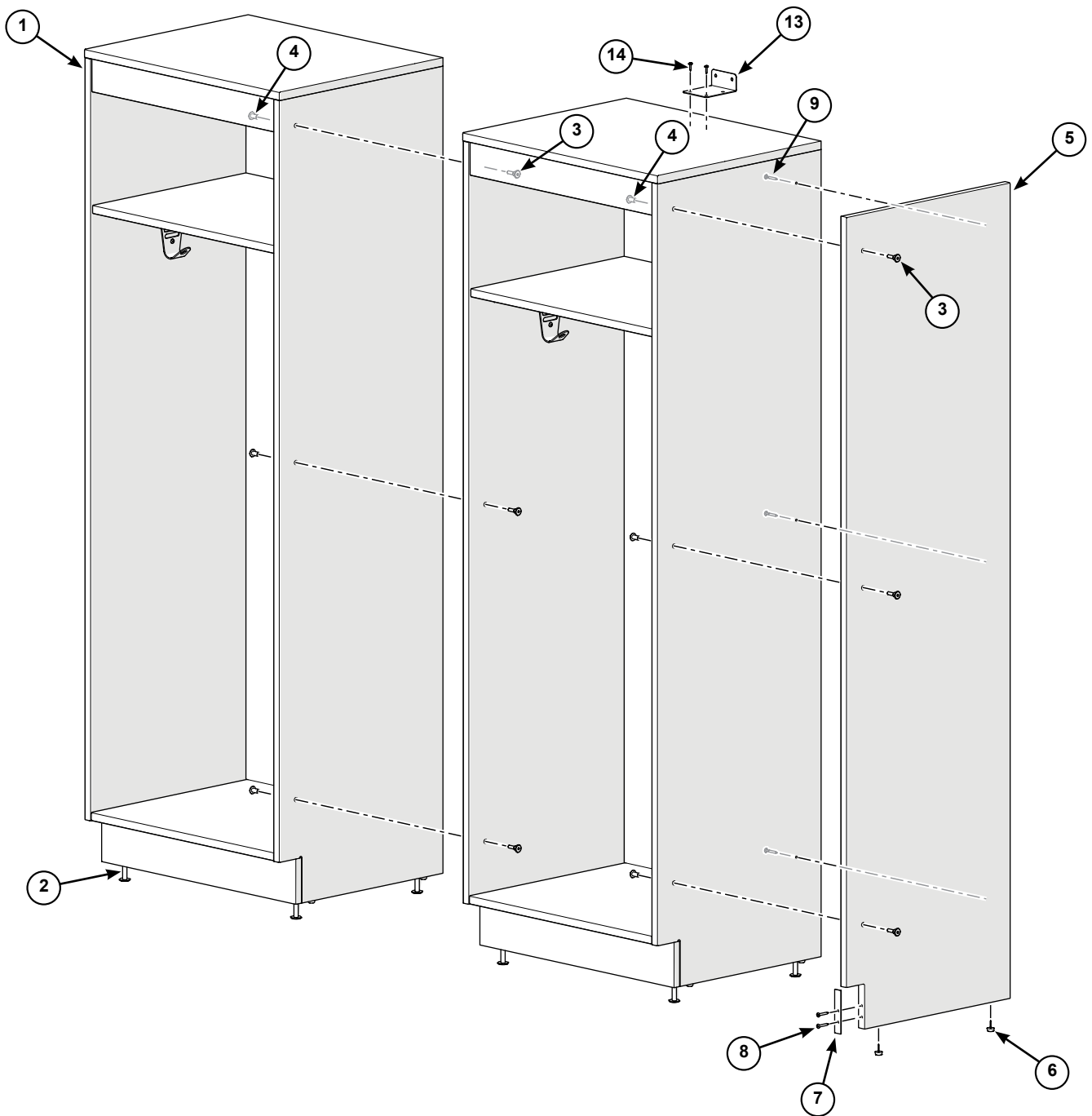



# Island Mount Configuration Locker Components

Item	Description	Item	Description	Item	Description
1	Locker Unit	6	Tack Glide	11	1/4-20 Insert Nut
2	Leveler	7	Toe Kick Cover Plate	12	Island End Cover Panel (Optional)
3	1/4-20 x 1.181" Connector Bolt	8	#8-15 x 1-1/4" Truss Head Screw	13	Connector Bracket
4	1/4-20 Cap Nut	10	1/4-20 x 1.77" Machine Screw	14	#8 x 5/8" Pan Head Screw

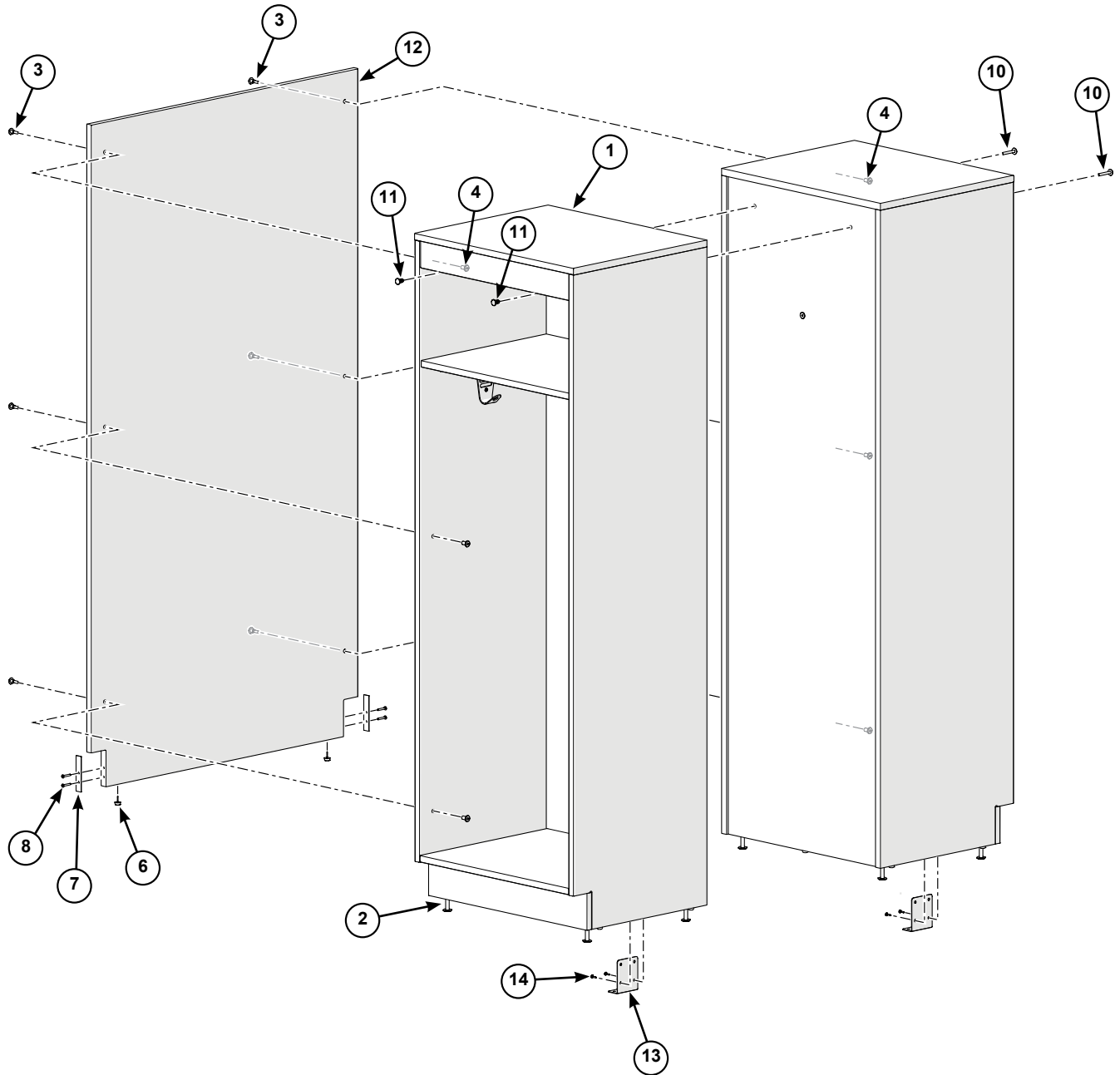

# Installation

---

## Unpacking

1. Unpack each individual locker unit.  
Use more than one person and take care to avoid damage.



2. Set each locker unit upright.

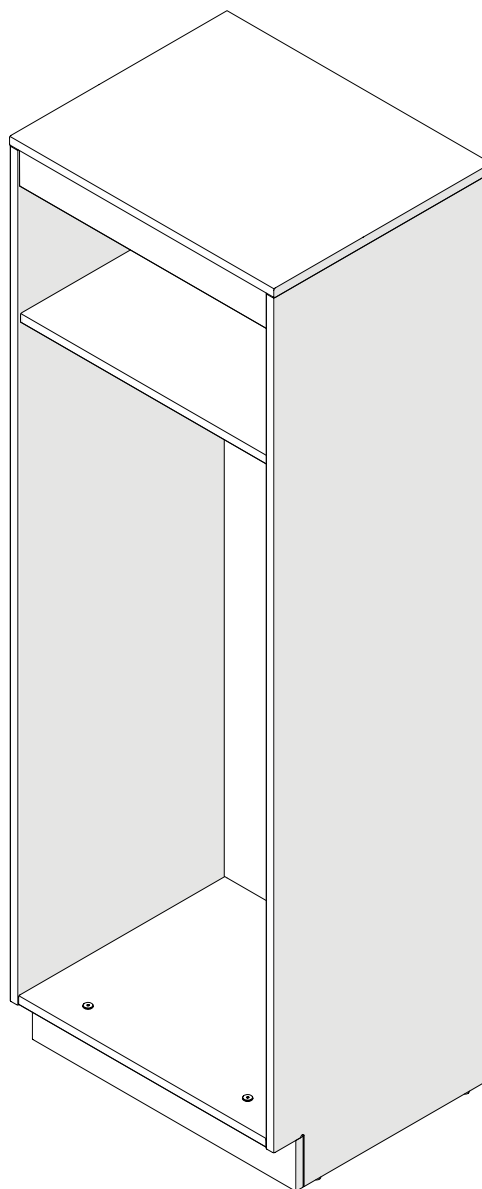

# Installation

---

## Leveling

The lockers must be leveled to each other before attaching them together.

1. The bottom shelf must be removed to access the levelers.
  - a. Remove the two screws that secure the shelf to the locker.
  - b. Pull the shelf out.
  - c. Set the shelf and screws aside to reattach later.
2. Move the lockers to be within a few inches of their final location according to the layout drawings.
3. Turn the levelers to adjust the height at each corner.

*Continued on the next page.*

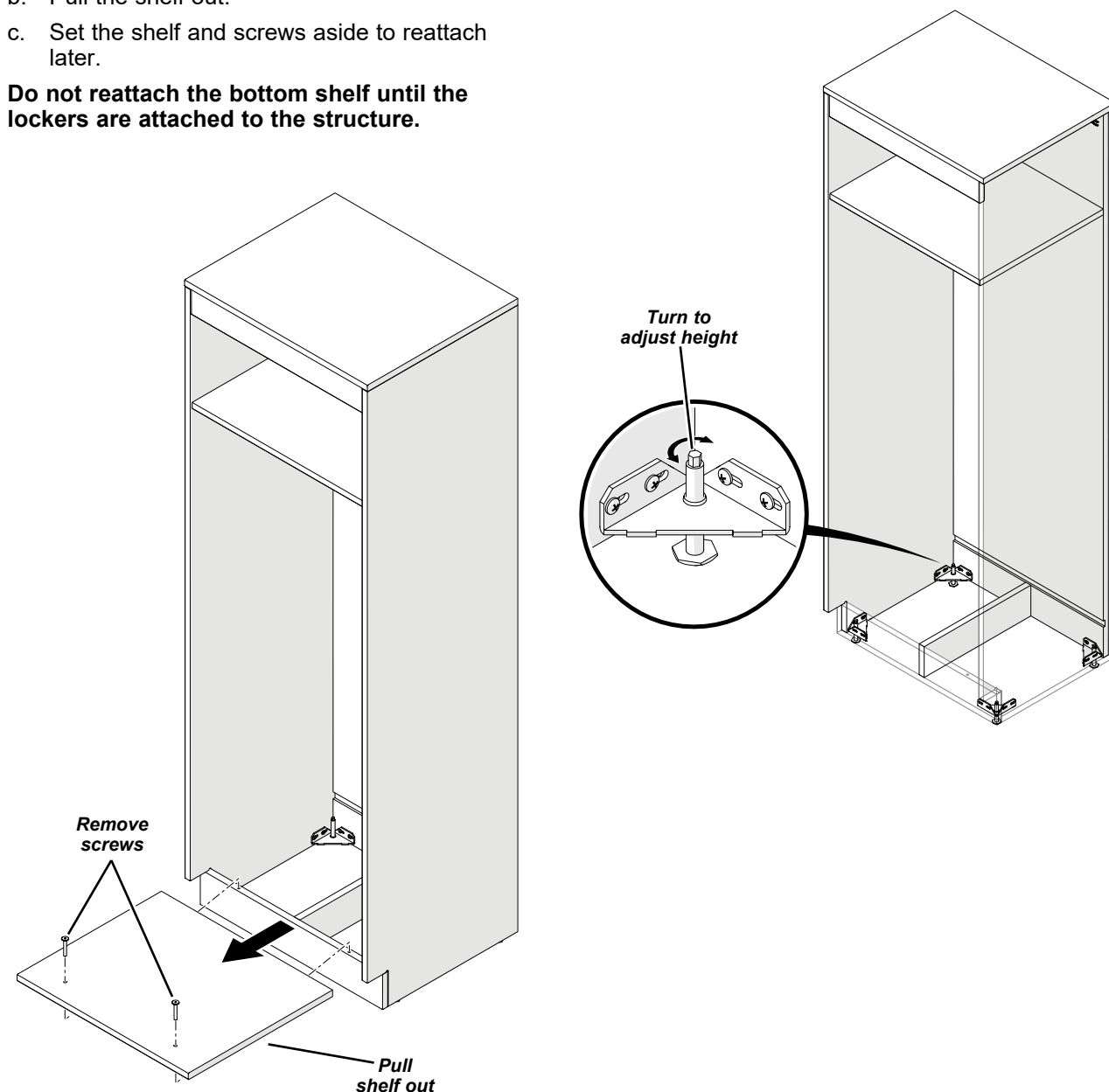

## Installation (continued)

### Leveling (continued)

4. a. Check the level of the entire floor where the lockers will be installed.
- b. Determine the highest point of the floor in that area.
- c. The locker installed at this highest location will be the reference for all other lockers to be leveled against.

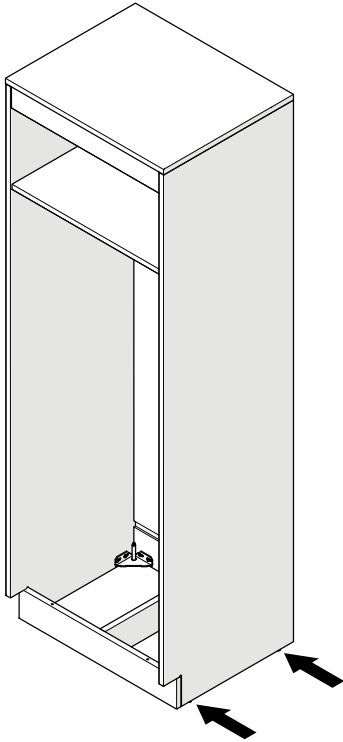

5. Adjust the levelers on one side until the front edges of the locker side panels are plumb (side-to-side).

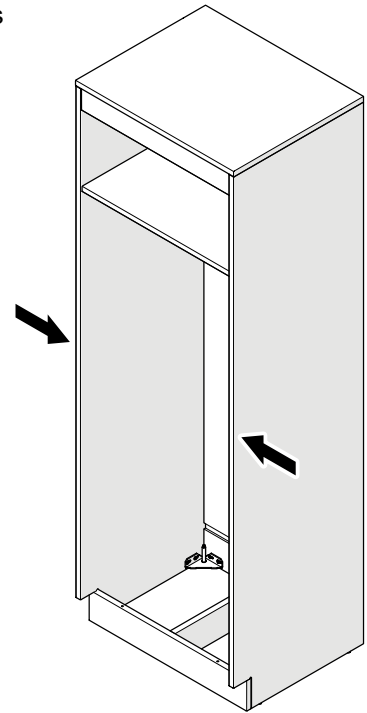

6. Measure A and B and adjust the front levelers until  $A=B$  (+1/32 inch).

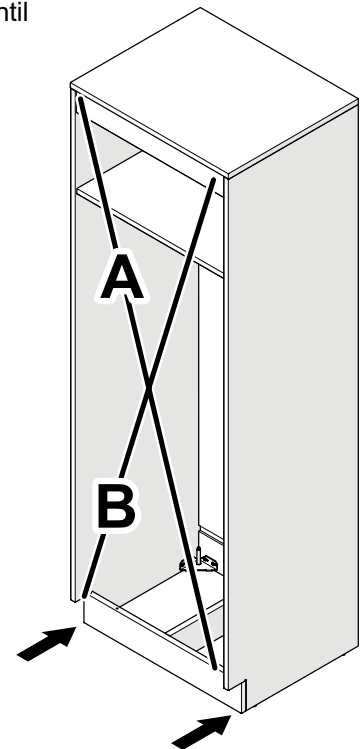

## Installation (continued)

### Leveling (continued)

7. Adjust both front levelers equally until the front edges of the locker are plumb (front-to-back).

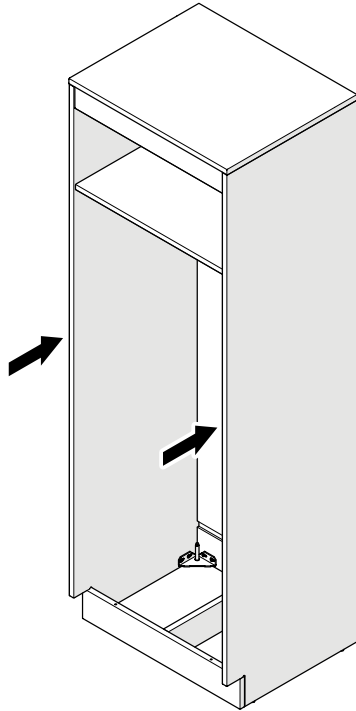

8. Recheck that  $A=B$ . Readjust if necessary (repeat steps 4-6).

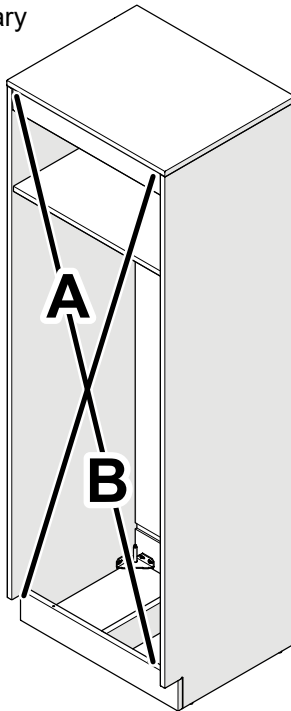

9. Adjust the levelers on the adjacent locker so it will line up with the top of the highest locker.

Confirm that adjacent lockers are level using a connector bracket or carpenter's level across the tops.

*Adjacent lockers must be level along tops*

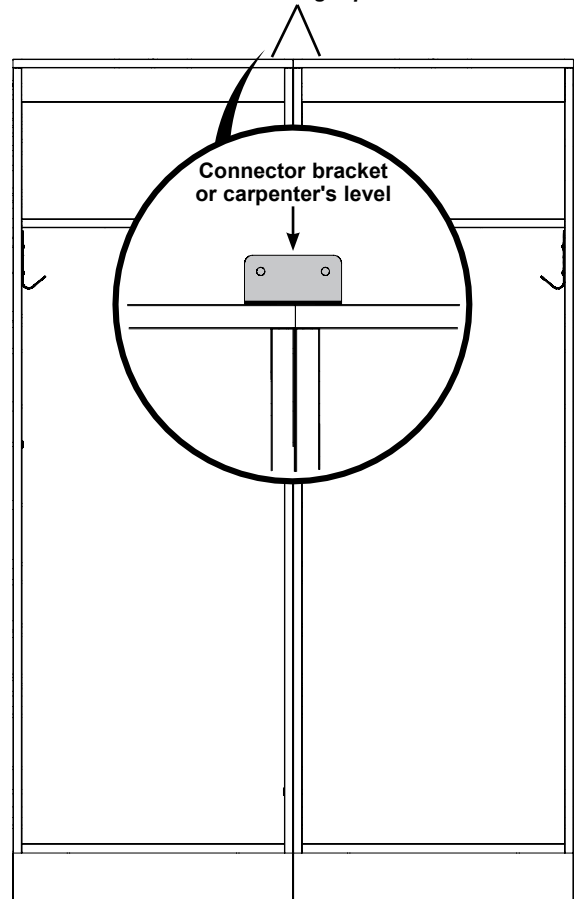

10. Repeat steps 5-9 for the remaining lockers.

## Installation (continued)



*This procedure is for securing the sides of adjacent lockers.  
Island mount lockers will require additional steps on the next pages.*

*For standard installations only, see separate seismic instructions if required.*

### Connect All Locker Sides Together

There are three holes at the front of the side panels for securing adjacent lockers together.

See Detail A1. All adjacent locker sides must be connected together.

See Detail A2. Island mount lockers must also be connected together at the back in addition to the sides.

### **CAUTION**

*All adjacent locker sides must be connected together.*

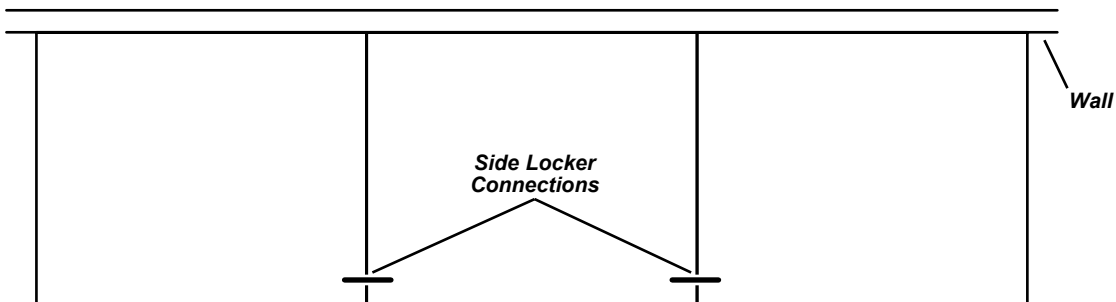

Detail A1 - Top View of Wall Mounted Lockers

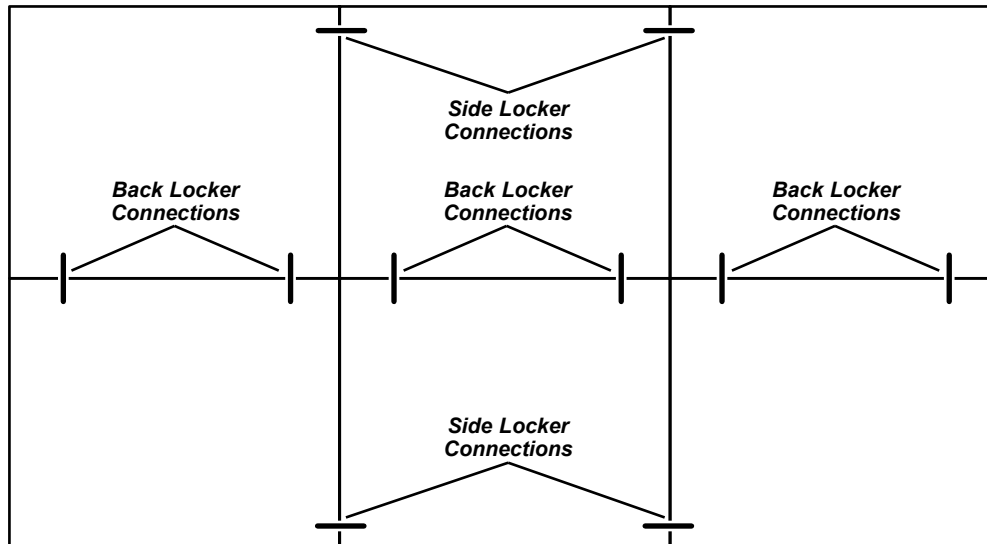

Detail A2 - Top View of Island Mounted Lockers

## ***Installation (continued)***

### ***Connect All Locker Sides Together (continued)***

1. Check that each locker is level vertically and adjacent lockers are level along the tops. Make any necessary leveling adjustments before connecting the locker sides together.
2. Be sure that the front pilot holes in the end panels are aligned and connect the locker units together using 1/4-20 x 1.181" connector bolts (3) and 1/4-20 cap nuts (4).

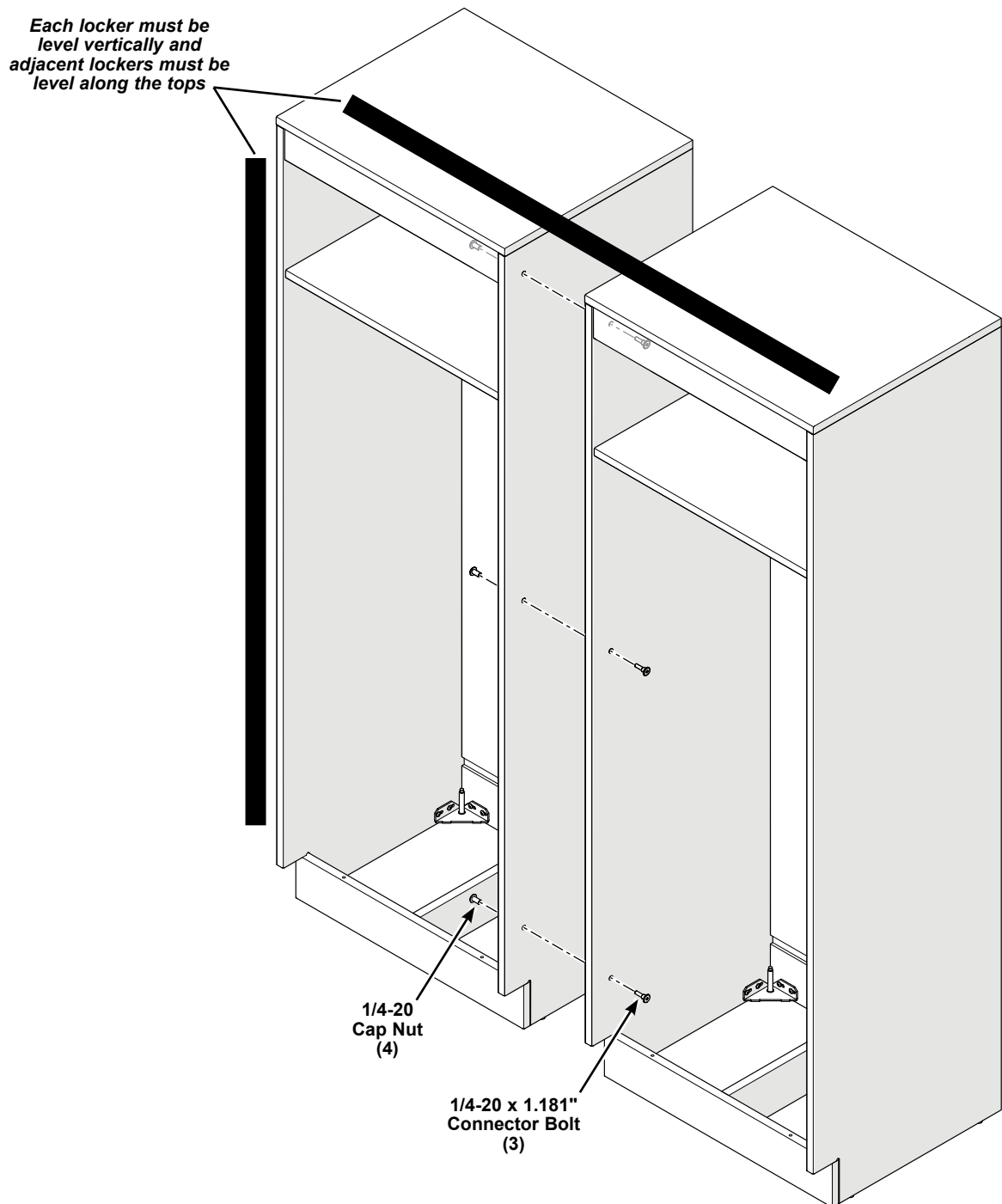

3. If installing island mounted lockers continue to the next page.  
If installing wall mounted lockers skip to page 17.

## Installation (continued)



**This procedure is for securing the backs of adjacent island mount lockers. The sides of the lockers must already be connected as described on the previous page.**

**This instruction is for standard installation only.**

**For seismic installation, see the instructions included with the Seismic Island Kit 243A028.**

### **CAUTION**

**In an island configuration, the adjacent locker backs must also be connected in addition to the sides of the lockers.**

### **Connect Locker Backs Together (island mount lockers only)**

**NOTE:** If lockers are installed in a back-to-back configuration, two holes must be drilled through both lockers to secure the adjacent backs together.

**NOTE:** Make sure the locker sides are secured together before attaching them back-to-back.

1. From inside one locker, drill two 3/8" holes 3" down from the top of the inside through the backs of both lockers.

These holes should be a minimum of 4" in from the sides of the locker.

2. Use a plastic mallet to pound 1/4-20 insert nuts (11) from the inside of one of the lockers and install 1/4-20 x 1.77" machine screws (10) from the other side and tighten.

3. Skip to page 18.

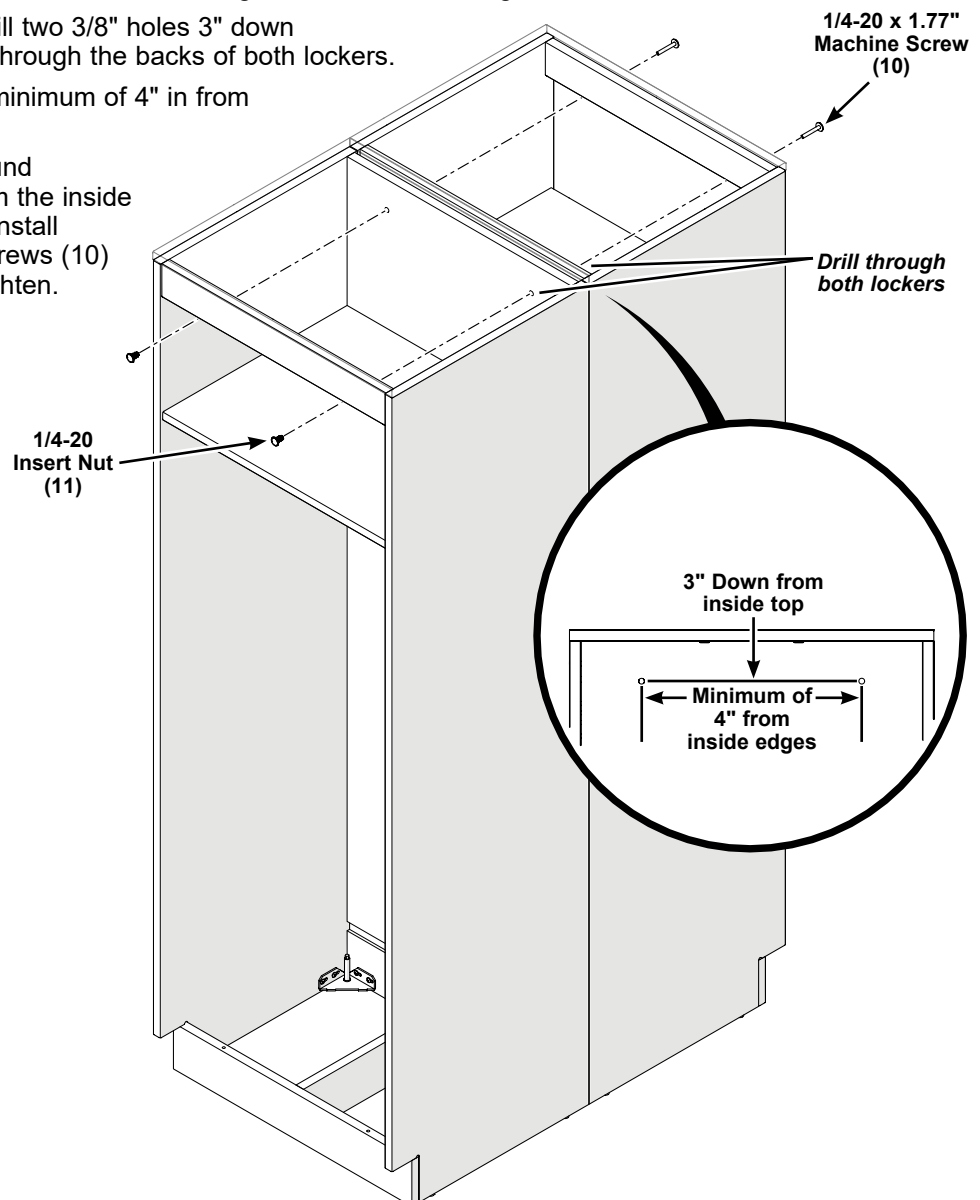



## Installation (continued)



*This procedure is for securing wall mount lockers to the structure.  
See the next page for securing island mount lockers to the structure.*

*This instruction is for standard installation only.*

*For seismic installation, see the instructions included with the Seismic Wall Kit 243A024.*

### CAUTION

*In addition to the sides of the lockers being secured, the locker backs must also be attached to a back wall.*

### WARNING

*Inferior or improperly installed fasteners could cause the lockers to tip over.*

### Secure Lockers to Back Wall (wall mount lockers only)

Because materials and construction of walls can vary, fasteners for attaching the lockers to the structure are not provided. The installer must choose the appropriate fastener and follow the manufacturer's instructions. See "Fasteners - Not Supplied" on page 5 for more information.

**NOTE:** At least every 2nd locker must be secured to the back wall.

**NOTE:** Make sure all adjacent locker sides are secured together before attaching them to the back wall.

1. Place the connector bracket (13) onto the top of the locker and position it to be flush with the back wall.
2. Secure the bracket to the locker using a minimum of two #8 x 5/8" pan head screws (14).  
The brackets have extra holes for the best fit on the top of the locker.
3. Secure the bracket to the wall using the appropriate fasteners.
4. Reattach the bottom shelves in the lockers.

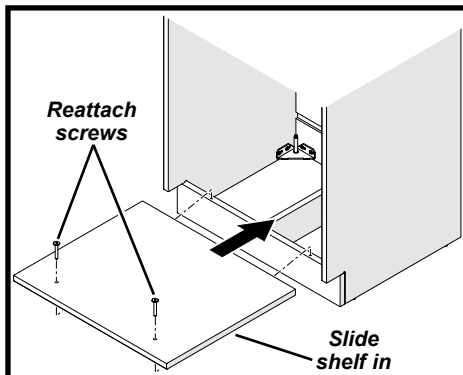

5. Install any optional equipment as shown on the following pages before continuing to "Finalize Installation" on page 23.

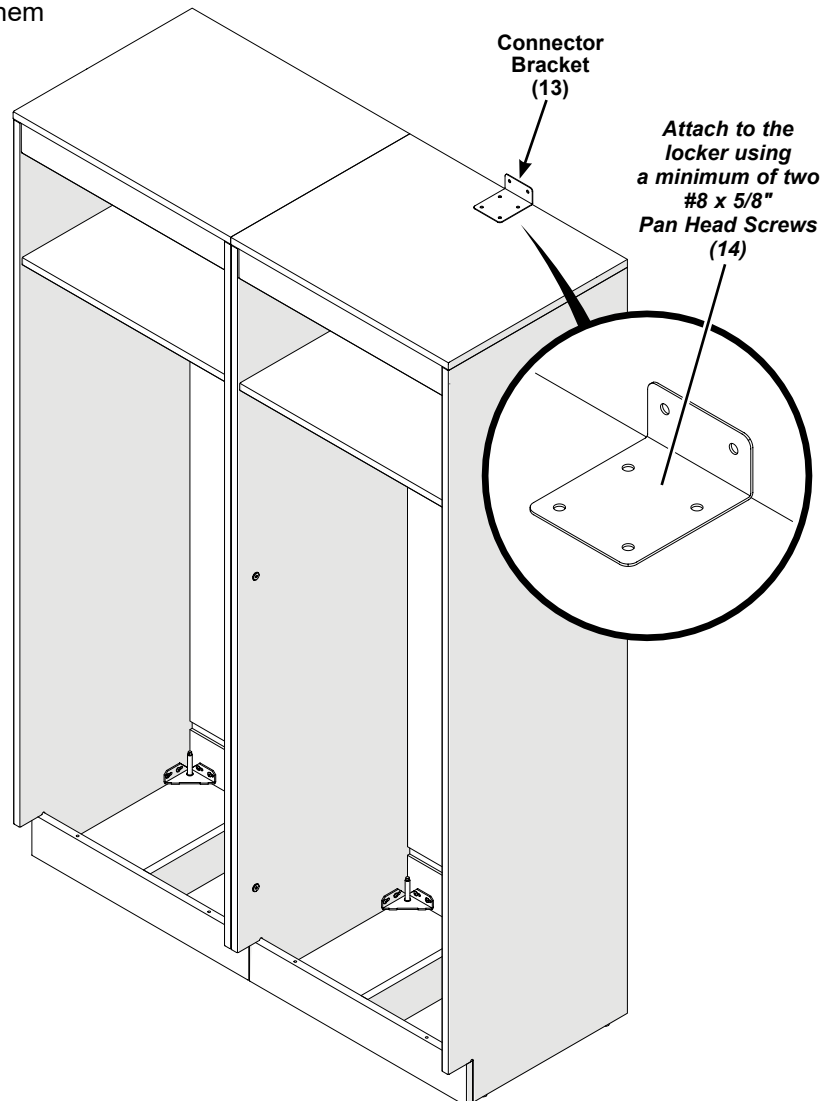

## Installation (continued)



This procedure is for securing island mount lockers to the structure.  
See the previous page for securing wall mount lockers.

This instruction is for standard installation only.

For seismic installation, see the instructions included with the Seismic Island Kit 243A028.

### CAUTION

In addition to the sides and backs of the lockers being secured, the lockers must also be attached to the floor.

### WARNING

Inferior or improperly installed fasteners could cause the lockers to tip over.

### Secure Island Mount Lockers

Because materials and construction of walls can vary, fasteners for attaching the lockers to the structure are not provided. The installer must choose the appropriate fastener and follow the manufacturer's instructions. See "Fasteners - Not Supplied" on page 5 for more information.

**NOTE:** The end of every locker bank must be secured to the floor.

**NOTE:** Make sure all the lockers are secured together before attaching them to the floor.

1. At the ends of the locker bank, attach one connector bracket (13) to the bottom inside of each locker using a minimum of two #8 x 5/8" pan head screws (14).

The brackets have extra holes for the best fit.

2. Secure the bracket to the floor using the appropriate fasteners.
3. Reattach the bottom shelves in the lockers.

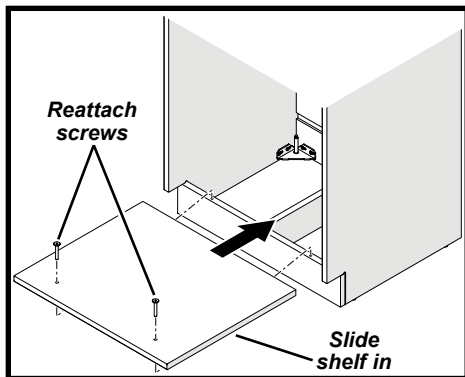

4. Install any optional equipment as shown on the following pages before continuing to "Finalize Installation" on page 23.

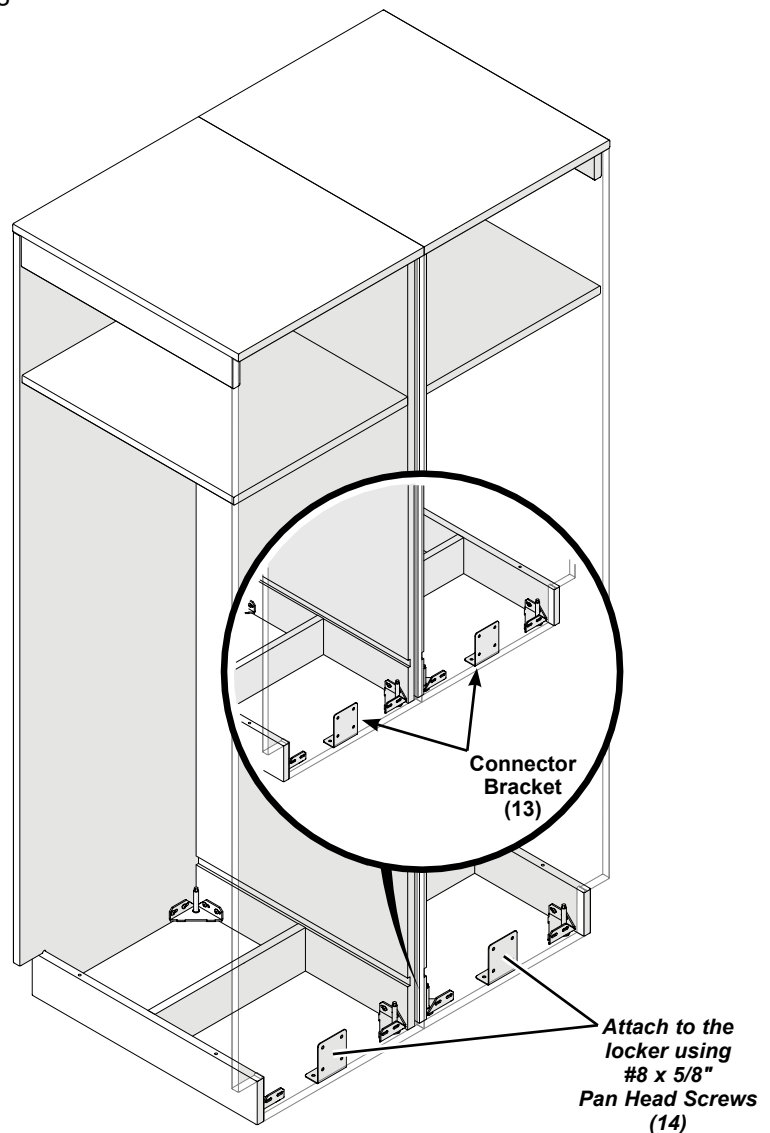

## End Cover Panel Option



End cover panels may be attached to cover exposed ends of locker formations.

For Single End Cover Panel attachment, see page 20.

For Island End Cover Panel attachment, see page 21.

### Assembly

1. Carefully remove the end cover panel from the package.
2. Pound two plastic tack glides (6) into the bottom edge, centered and 2"-3" from each end.
3. Attach one toe kick cover plate (7) to the bottom notched edges of the end cover panel using two #8-15 x 1-1/4" truss head screws (8).

Single end cover panels (5) use one cover plate.

Island end cover panels (12) use two cover plates.

4. If attaching a single end cover panel, go to the next page.  
If attaching an island end cover panel, skip to page 22.

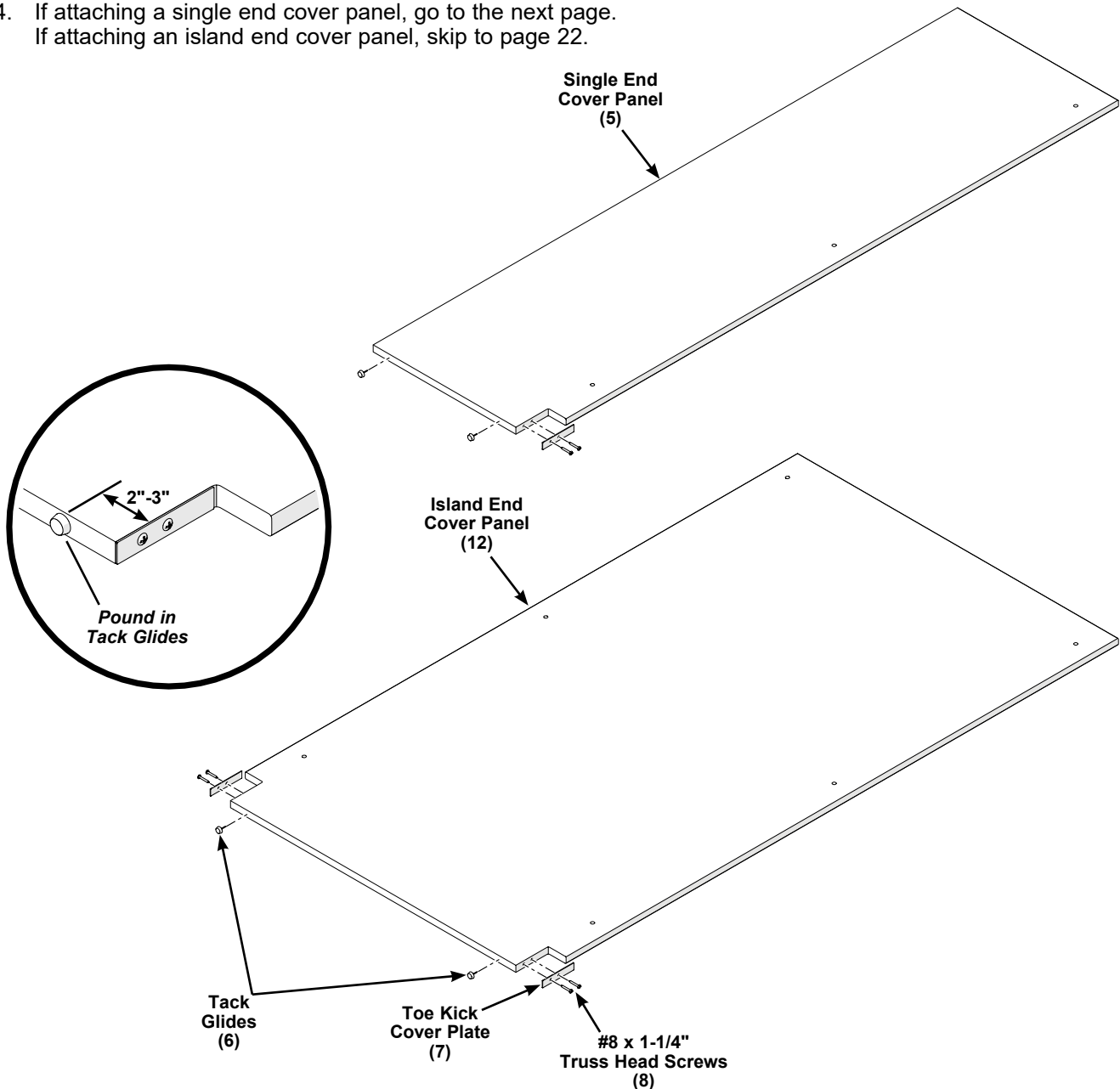

## End Cover Panel Option (continued)

### Single End Cover Panel Attachment

- To further secure the single end cover panel, screws must be installed through the rear of the end locker.
  - From the outside of the locker at the end of the locker formation, measure and mark for three holes. These holes should be parallel with the existing holes in the front of the locker and 2-1/2"-3" in from the back of the locker as shown.
  - Drill three 5/32" holes completely through the locker.
- Raise the single end cover panel into position covering the cabinet side and flush with the front edge. Be sure that the front holes in the single end cover panel (5) are aligned with the front holes in the locker.
- Attach the front of the single end cover panel to the locker using three 1/4-20 x 1.181" connector bolts (3) and 1/4-20 cap nuts (4).
- Attach the back of the end cover panel using three #8 x 1-3/8" wood screws (9) through the locker holes drilled in Step 1 and into the end cover panel.

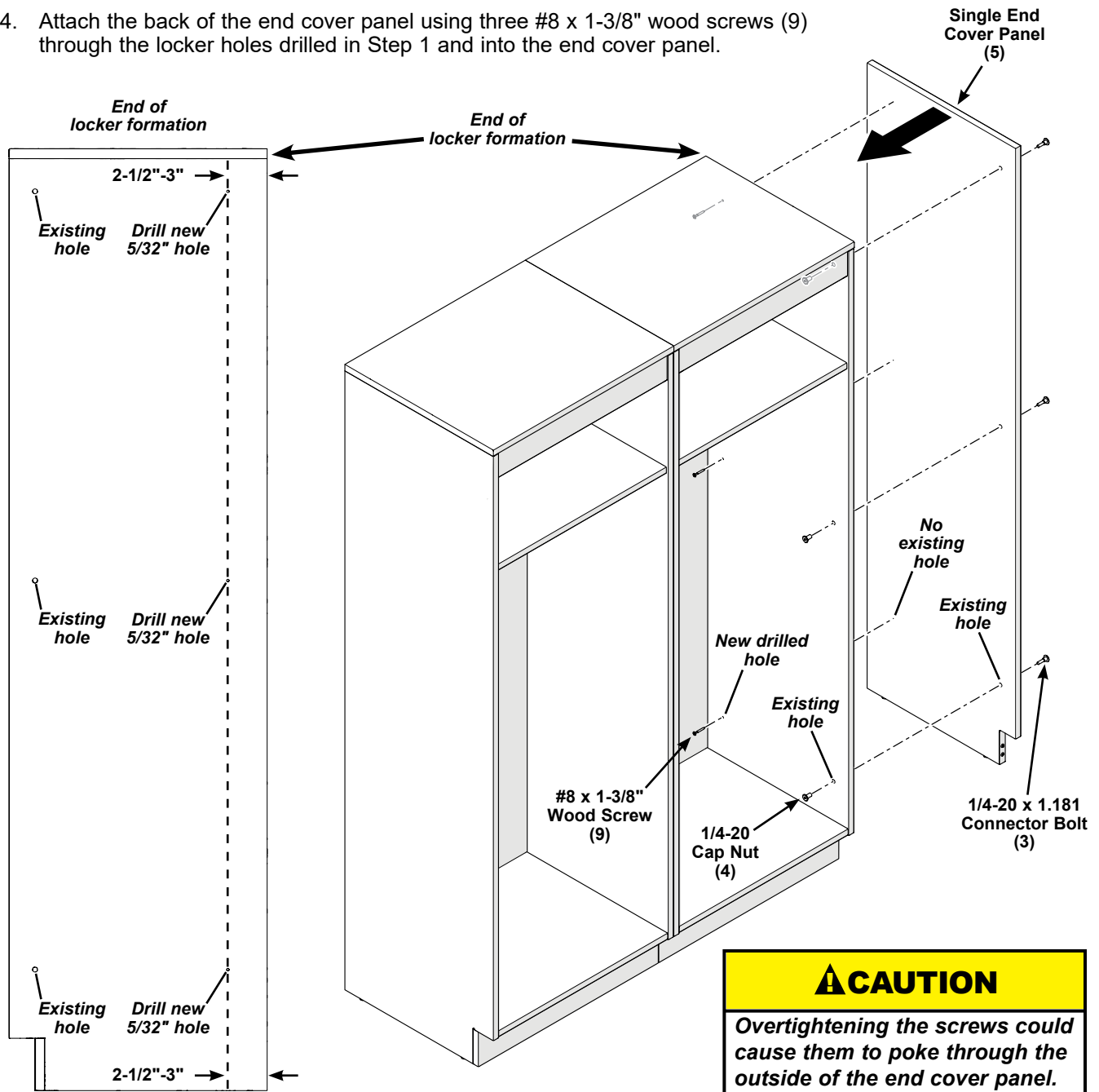

## ***End Cover Panel Option (continued)***

---

### ***Island End Cover Panel Attachment***

1. Raise the single end cover panel into position covering the locker side and flush with both edges. Be sure that both sets of pilot holes in the island end cover panel (12) are aligned with the pilot holes in both lockers at the end of the formation.
2. Attach both edges of the island end cover panel to both lockers using six 1/4-20 x 1.181" connector bolts (3) and 1/4-20 cap nuts (4).

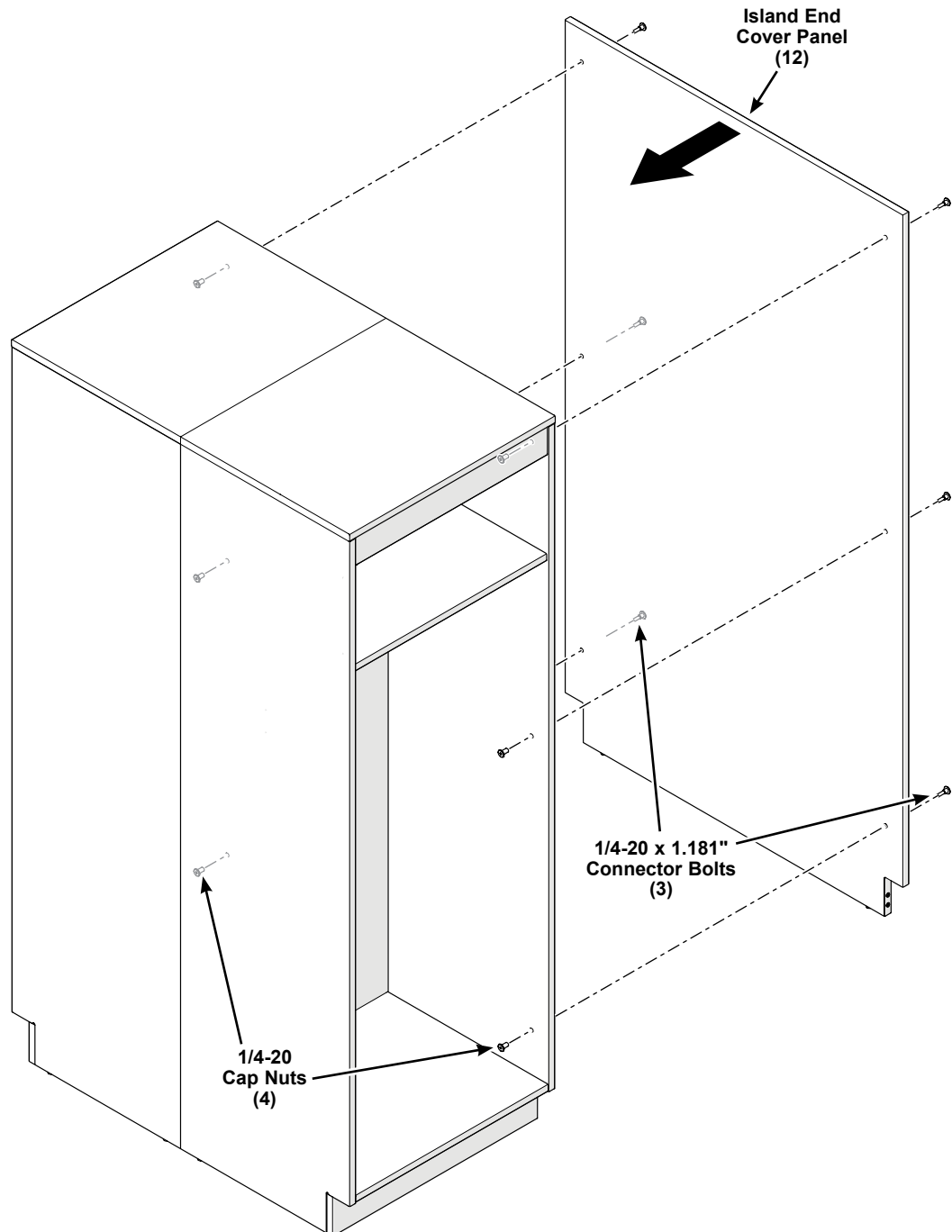

## Helmet & Shoulder Pad Holder Accessory Installation

A helmet & shoulder pad holder option can be installed on top of the locker.



**A minimum 30" (762 mm) of clearance is recommended between the top of the locker and the ceiling to allow fitting the equipment.**

1. Place the helmet & shoulder pad holder (19) to be centered over the four holes on top of the locker.
2. Secure the holder to the top of the locker using four 3/8-16 x 3/4" flange bolts (20) into the already installed insert nuts.

**NOTE:** The lips of the flange bolts hold it in place as shown.

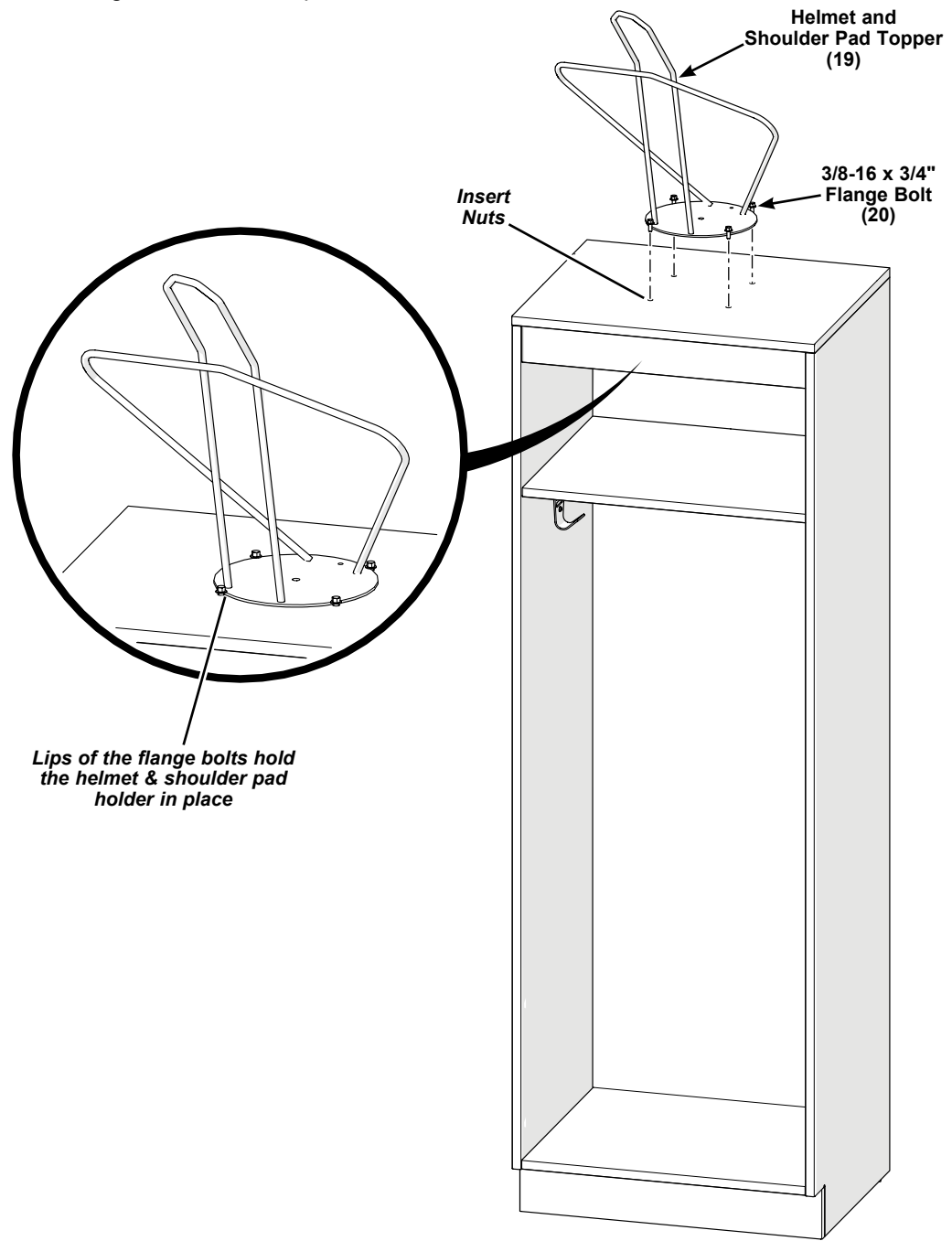

## Finalize Installation

### Plug Empty Holes

Any unfilled holes in the locker sides can be plugged by either pushing in 1/4-20 insert nuts (11) or gluing in 1/4-20 cap nuts (4).

### Tighten All Fasteners

Check to see that all fasteners used for the installation are tight.

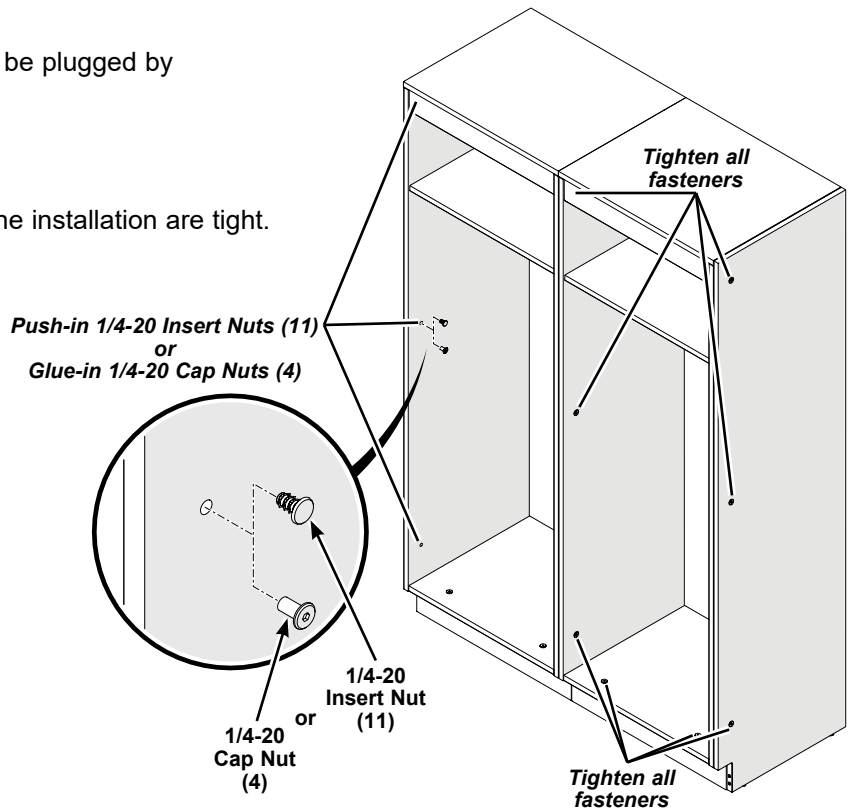

## Care and Maintenance

### Electronic Lock

If the locker has an electronic lock, **the default user code is 2244**. Contact Wenger for information about updating the codes.

### Cleaning

For removal of mild stains and mild scuff marks, panels and shelves may be cleaned using an all-purpose household cleaner or just simple mild soap and water.

For heavier scuff marks, ink stains, felt pen and magic marker stains, or other tough stains; use a nonabrasive cleaner, or an industrial all-purpose cleaner.

Ammoniated or vinegar-based glass cleaners also work well for these stains.

Do not use harsh abrasive cleaners, as permanent damage could occur to the panel surface. Be sure to quickly remove all cleanser residues with water and wipe dry with a soft cloth.

### Humidity Control

To insure longevity of panel performance, maintain the relative humidity between 25% - 55% at the permanent installation site.

### Fasteners

Check fasteners after each season to ensure that they are not loose or dislodged.

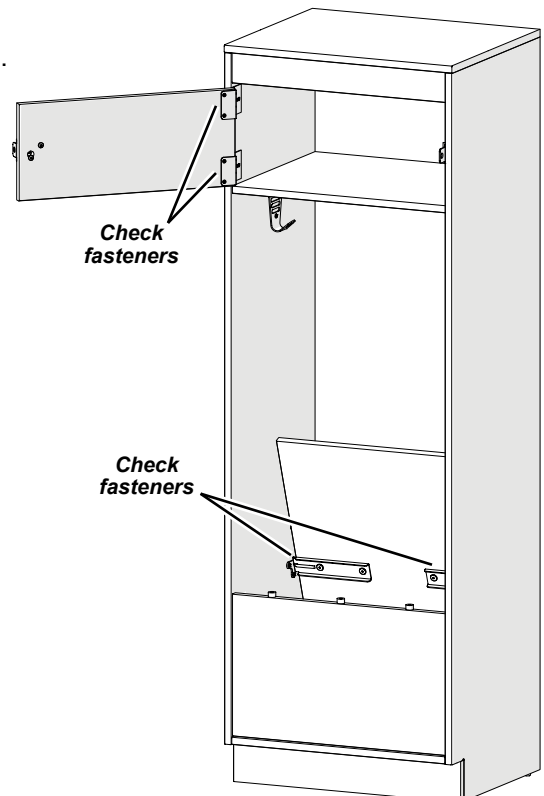

# Replacement Parts

Item	Description	Item	Description	Item	Description	Item	Description
1	Hook Bracket	6	Nameplate*	11	Padded Seat Cushion*	16	Top Shelf
2	Garment Bar*	7	Cubby Door*	12	Left Side Panel	17	Back Panel
3	Fixed Seat*	8	Hasp Lock*	13	Marquee Panel	18	Bottom Shelf
4	Foot Locker Shelf*	9	Hinged Seat*	14	Top Panel	19	Toe Kick Panel
5	Helmet & Shoulder Pad Holder*	10	Digital Lock*	15	Right Side Panel	20	End Cover Panel

\*Optional component

