

 NIAGARA



NANO™

0.5/0.8 GPF Dual Flush Toilet Compact Elongated Bowl with 12" Rough-In



NANO™

0.5/0.8 GPF DUAL FLUSH TOILET

Compact Elongated Bowl with 12" Rough-In

FEATURES

- Quiet, powerful flush delivered with a patented Stealth flush chamber and air transfer system
- Reliable standard Fluidmaster fill valve
- One flush thoroughly evacuates the bowl every time, eliminating double flushing
- Compact elongated shape offers comfort while occupying the same space as a round bowl
- Two-piece toilet
- Stylish, inconspicuous and durable flush button
- EZ Height design makes it easier to sit and stand
- No flapper to cause leakage

SPECIFICATIONS



Materials: Vitreous China

Finish Color: White

ASME Certification: A112.19.2

CSA Certification: B45.1

MEASUREMENTS

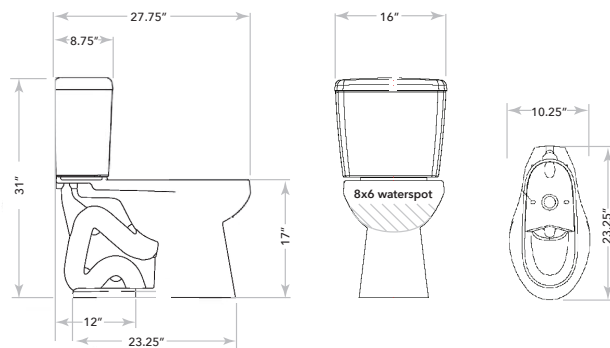

BULK PACKAGING

N7737EB Compact Elongated Bowl	
UPC Code	732291773713
Packaging Type	Kraft Corrugated
Packaging Dimensions	15.5" W 17.5" H 28.5" D
Packaging Weight	51.2 lbs
Skid Quantity	18 or 12
N7747T-DF Tank	
UPC Code	732291774727
Packaging Type	Kraft Corrugated
Packaging Dimensions	9" W 17.5" H 17" D
Packaging Weight	32.8 lbs
Skid Quantity	30

*LIMITED LIFETIME WARRANTY on vitreous china products. Toilet tank trim: fill valve and flush valve assembly and plumbing fittings are warranted for a period of ten (10) years to the purchaser from the date of purchase. Call Niagara for complete warranty details.

CORPORATE HQ 1200 Lakeside Parkway, Suite 450, Flower Mound, Texas 75028 USA

(t) 800.831.8383 (p) 817.391.0800 (f) 682.200.6962 (e) info@niagaracorp.com

© 2018 Niagara Conservation May 8, 2018 2:15 PM

niagaracorp.com