

STABIL'X® X STACKER™

GET ALL THE BENEFITS OF MICHELIN®
RADIAL TIRE TECHNOLOGY!

With the STABIL'X® X STACKER™, you will get:

- Improved damage resistance
- Increased productivity
- Enhanced maneuverability in tight spaces



THE TIRE OF CHOICE FOR:



REACH STACKERS



CONTAINER
HANDLERS



The long-lasting Michelin® radial tire designed to increase the productivity of reach stackers and container handlers in difficult to extremely severe working conditions.

Exceptional Performance:

- Excellent traction; outstanding stability; enhanced operator comfort; less vehicle damage

Excellent Productivity:

- Resistance to impacts and cuts means fewer flats

Low Operating Costs:

- Long-lasting, even-wearing tread pattern; durable with low rolling resistance for efficient fuel economy; easy to repair



STABIL'X® X STACKER™

SIZE	TREAD DEPTH
	32nds MM
18.00R25	113 90

Increased Wear Resistance

New massive slick tread with increased tread depth is designed for long life.

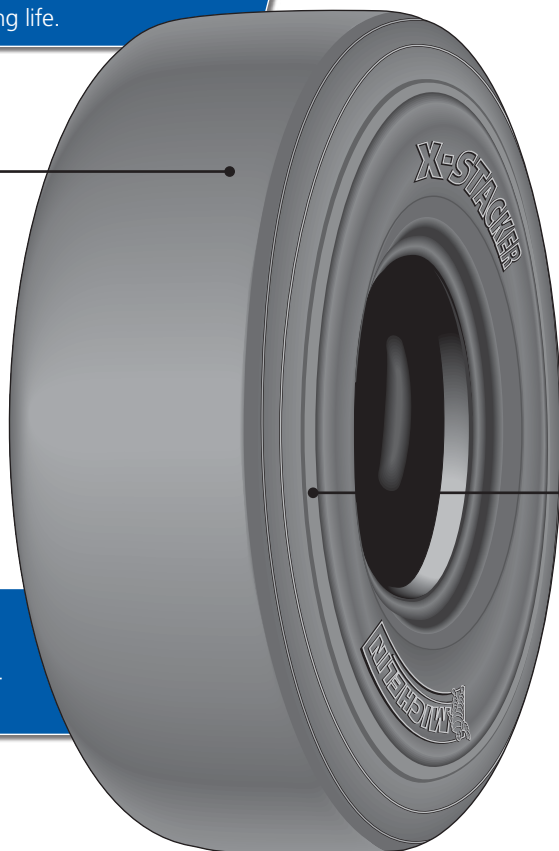

More Productivity

The STABIL'X® X STACKER™ decreases the cost-per-hour ratio by 27% for cycles less than 5 km/h*. Low rolling resistance improves fuel economy.

Better Mileage

Revolutionary rubber compound reduces cost-per-hour by up to 55%*.

Significant Reduction in Downtime

Flexible radial casing, reinforced crown and sidewall areas help enhance reliability.

*Versus the Michelin® STABIL'X® XZM™

MICHELIN NORTH AMERICA, INC.
One Parkway South, P.O. Box 19001, Greenville, SC 29602-9001
1-877-574-8473

www.michelinearthmover.com

© 2005 MNA, Inc.
MEL43002 (Rev 2/06)

