

**Get all the benefits  
of Michelin® radial  
tire technology!**

**With the STABIL'X®  
X STACKER™, you will get:**

- Improved damage resistance
- Increased productivity
- Enhanced maneuverability  
in tight spaces

**STABIL'X®  
X STACKER™**  
The tire of choice for:



Reach Stackers

# STABIL'X® X STACKER™

The long-lasting Michelin® radial tire  
designed to increase the productivity of  
reach stackers in difficult to extremely  
severe working conditions.

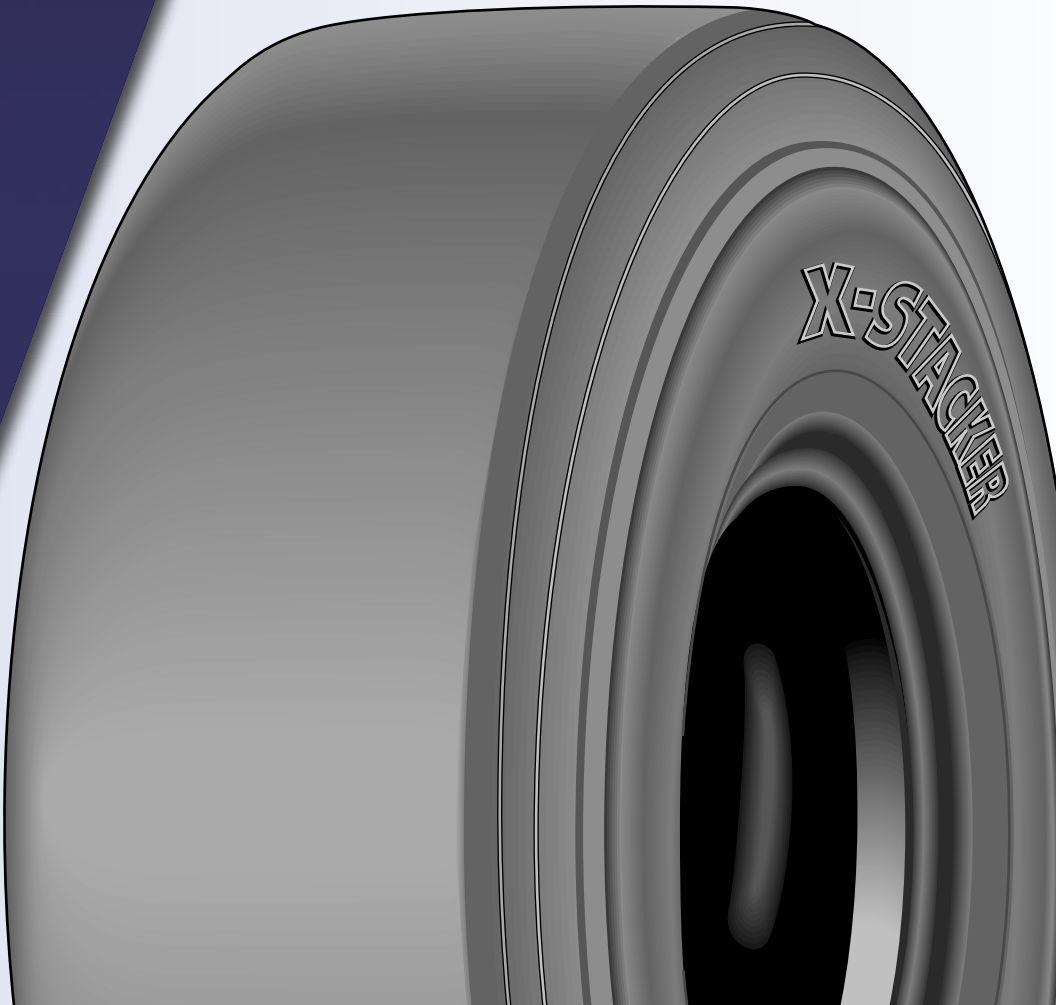

# The benefits of Michelin® radial tires

## Exceptional Performance:

- Excellent traction, outstanding stability and enhanced operator comfort – less vehicle damage.

## Excellent Productivity:

- Resistance to impact and cuts means fewer flats.

## Low Operating Costs:

- Long-lasting, even-wearing tread pattern, durable with low rolling resistance for efficient fuel economy, easy to repair.

## STABIL'X® X STACKER™

### PRODUCT OFFERINGS

#### Increased Wear Resistance

New massive slick tread with increased tread depth is designed for long life.

#### Better Mileage

Revolutionary rubber compound reduces cost-per-hour by up to 55%\*.

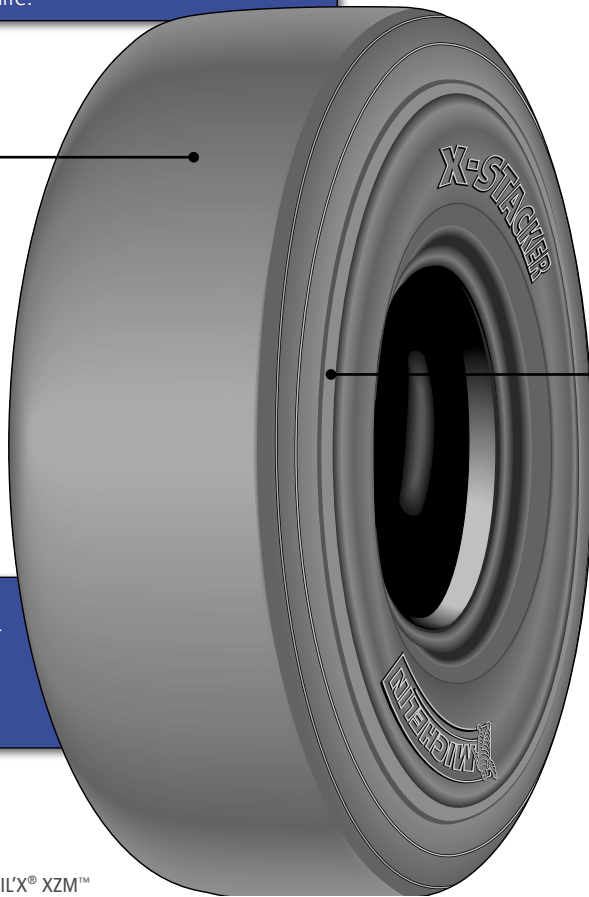

#### SIZE

#### TREAD DEPTH

	32nds	MM
18.00R25	113	90

#### More Productivity

The STABIL'X® X STACKER™ decreases the cost-per-hour ratio by 27% for cycles less than 5 km/h\*. Low rolling resistance improves fuel economy.

#### Significant Reduction in Downtime

Flexible radial casing, reinforced crown and sidewall areas help enhance reliability.

\*Versus the Michelin® STABIL'X® XZM™

[www.michelinearthmover.com](http://www.michelinearthmover.com)  
One Parkway South, P.O. Box 19001, Greenville, SC 29602-9001  
1-877-574-8473

© 2005 MNA, Inc.  
MEL43002

