



↖  
We make things MOVE®

# Collaborative Robot Vacuum Tool

## Unparalleled flexibility in collaborative robotics



## We Make Things Move®

A forward-thinking innovator, Bimba provides industry-leading pneumatic, hydraulic and electric motion solutions that are easy-to-use, reliable and ready for your engineering challenges.

Doing whatever it takes to help you get the job done is what the Bimba companies do best. With an extensive line of industry-leading air cylinders, rotary actuators, linear thrusters, rodless cylinders, NFPA, hydraulics, flow controls, position-sensing cylinders, valves, switches and air preparation equipment, the people of Bimba are ready to tackle your toughest applications.

Bimba is part of IMI Precision Engineering, a world leader in motion and fluid control technologies. Wherever precision, speed and engineering reliability are essential, we deliver exceptional solutions which improve the productivity and efficiency of customers' equipment.

Our range of high-performance products, such as actuators, valves, valve islands, pressure monitoring controls and air preparation products together with trusted products brands including IMI Norgren, IMI Buschjost, IMI FAS, IMI Herion and IMI Maxseal underpin our position as a leading global supplier.

Part of IMI plc, we have a sales and service network in 75 countries, as well as manufacturing capability in the USA, Germany, China, UK, Switzerland.

## Contents

---

**02** Introduction

---

**03** Collaborative Robot Vacuum Tool

---

**04** Product Features

---

---

**05** How It Works

---

**06** How It's Used

---

**08** How To Specify

---

---

**09** How to Accessorize

---

**10** How to Order

---

**11** How to Customize

---

# Collaborative Robot Vacuum Tool

The Collaborative Robot Vacuum Tool (CRVT) adds unparalleled flexibility to your collaborative robot. The standard CRVT is highly configurable to meet your application needs, but simple to install and operate. This fully integrated tool means all you need to supply is compressed air and a signal to control the valve. A variety of standard and custom options make the CRVT the perfect tool for your next collaborative robot project.



# Product Features

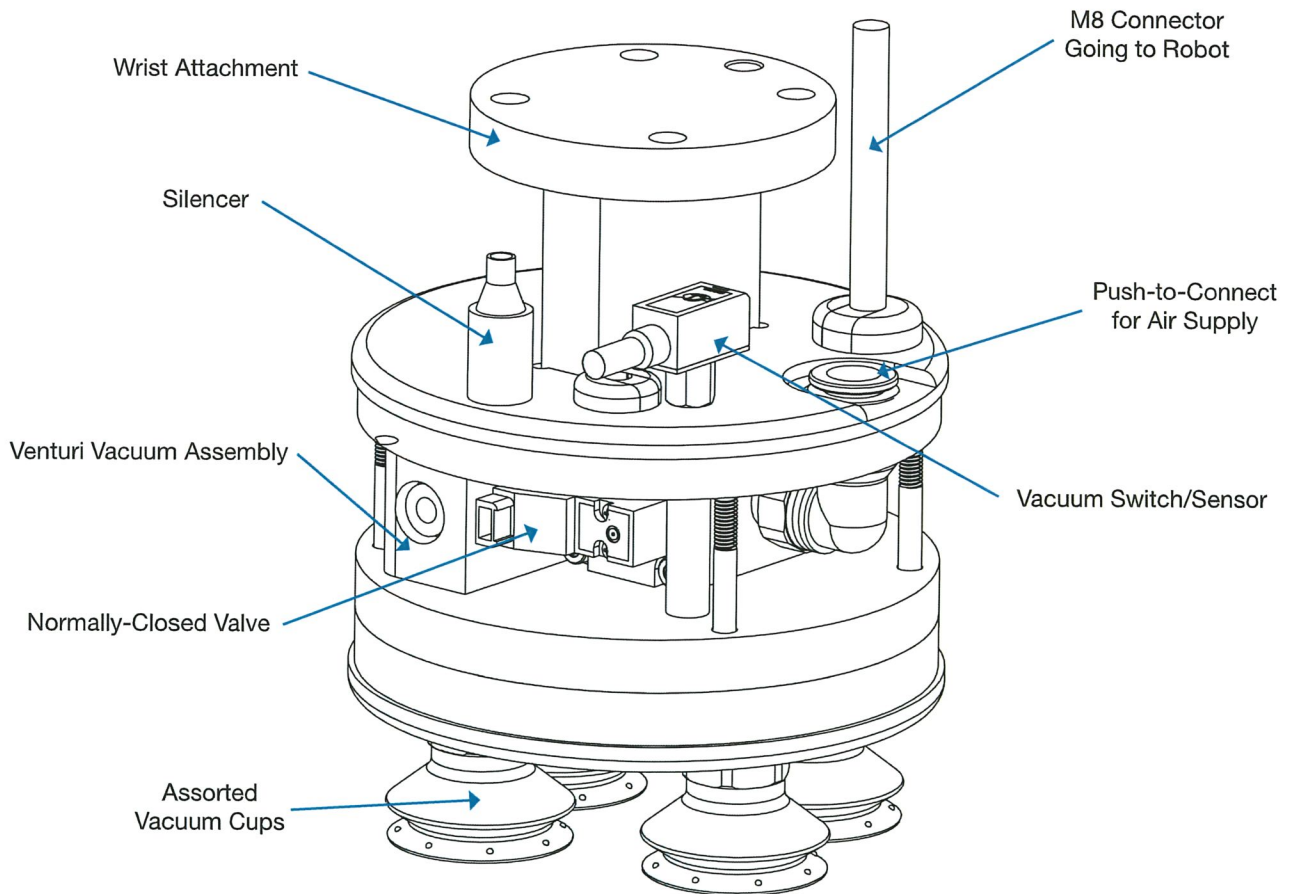

## Features and Benefits

- Plug and play operation: Just simply add air
  - » Mounting plate is designed for specific robot brand
  - » Adjustable vacuum switch for part detection
  - » Pre-installed muffler for quiet operation
  - » Integrated valve simplifies installation
  - » Mounting hardware included
- Stocked configurations:
  - » CRVTU-150M-80-P-#### for semi-porous applications
  - » CRVTU-100H-80-P-#### for non-porous applications
  - » Consult factory for assistance choosing the correct vacuum characteristics for your applications
- Standard vacuum ports:
  - » (1) 1/4" NPT female
  - » (4) 1/8" NPT female
- Consult factory for custom options

## Performance Characteristics

	Air consumption (scfm [slpm])		
	L	M	H
	10" Hg [339 bar]	20" Hg [677 bar]	28" Hg [948 bar]
060	N/A	0.5 [14.2]	0.8 [22.6]
090	0.5 [14.2]	1.4 [39.6]	1.8 [51.0]
100	1.4 [39.6]	1.8 [51.0]	2.8 [79.3]
150	1.8 [51.0]	2.8 [79.3]	4.8 [135.9]

	Approximate time to reach full vacuum (seconds) <sup>5</sup>		
	L	M	H
	10" Hg [339 mbar]	20" Hg [677 mbar]	28" Hg [948 mbar]
060	N/A	1.2	4.2
090	0.2	0.6	1.5
100	0.1	0.3	1.3
150	0.1	0.3	0.7

	Maximum recommended load (lb [kg]) <sup>1</sup>		
	L	M	H
	10" Hg [339 mbar]	20" Hg [677 mbar]	28" Hg [948 mbar]
1DSB	3.9 [1.8]	7.9 [3.6] <sup>2</sup>	11.0 [5.0] <sup>3</sup>
4DSB	5.5 [2.5] <sup>2</sup>	10.9 [4.9] <sup>3</sup>	15.3 [6.9] <sup>3</sup>
1SFL	8.5 [3.9] <sup>2</sup>	17.1 [7.8] <sup>3</sup>	23.9 [10.8] <sup>4</sup>
4SFL	4.8 [2.2] <sup>2</sup>	9.5 [4.3] <sup>3</sup>	13.3 [6.0] <sup>3</sup>

**NOTES:**

- <sup>1</sup> 4X factor of safety applied
- <sup>2</sup> Exceeds load capacity of UR 3
- <sup>3</sup> Exceeds load capacity of UR 5
- <sup>4</sup> Exceeds load capacity of UR 10
- <sup>5</sup> Actual time will vary based on cup selection, leakage and part shape
- <sup>6</sup> Average performance data shown. All data is for reference only. Please contact factory for assistance with your application

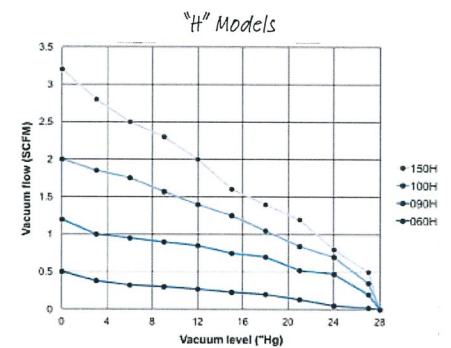
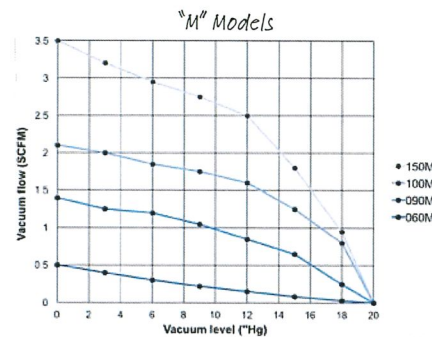
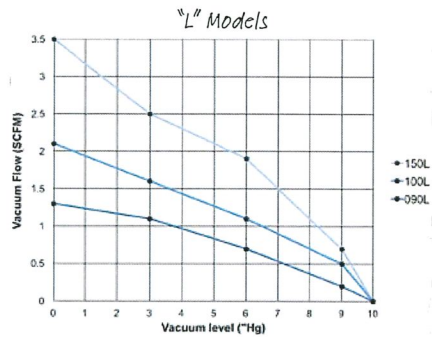

## Wiring Pinout

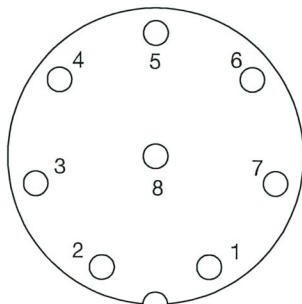

M8 Female CRVTA, CRVTU

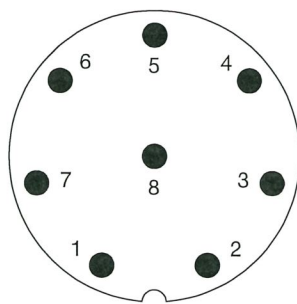

M12 Male CRVTR

	Pin 1	Pin 2	Pin 3	Pin 4	Pin 5	Pin 6	Pin 7	Pin 8
CRVTU	-	Switch	-	Sensor	24V (Power)	-	Valve	Ground
CRVTA	Ground	24V (Power)	Valve	Switch	-	-	Sensor	-
CRVTR	24V (Power)	Valve	-	Sensor	Sensor GND	Switch	-	Sensor GND

# How It's Used

## Application Ideas

- Pick & place
- CNC machine automation
- Packaging and palletizing
- Assembly
- Lab analysis and testing
- Machine tending

## Target Applications

The Collaborative Robot Vacuum Tool (CRVT) is an end of arm tool designed specifically for the needs of the collaborative robot market. The CRVT combines a single stage venturi vacuum pump, vacuum switch or sensors, and a valve in a simple, easy-to-use package. This allows it to be used anywhere you need to grip a part with a collaborative robot.



## Advantages

Feature	Advantage	Benefit
Vacuum pump mounted at work piece	Faster response	The vacuum pump has less volume to evacuate, allowing for a faster response time and firmer hold.
Integrated valve	Easier to install	A single connector supplies the power and I/O to the tool, simplifying installation.
Pressure switch	Part detection	The integrated vacuum switch signals the robot when a set vacuum level is achieved, ensuring the robot picks a part before it moves

## Set-up - Universal Robots

1. Mount the tool to the robot wrist using the four (4) mounting bolts supplied.
2. Ensure the I/O cable can reach the Tool I/O connector on the wrist.
3. Connect the M8 connector to the Tool I/O connector on the Universal Robot.
4. Connect the 3/8" polyurethane tube to the tool.
5. Route and secure the tubing along the length of the robot ensuring enough slack to allow the robot to move freely.
6. Connect tubing to a filtered and regulated air supply set to 60 or 80 PSI depending on tool.\*
7. The Collaborative Robot Vacuum Tool uses the Universal Robot Tool I/O to control the tool. All configuration is done in the Universal Robot Graphical User Interface (GUI). Set the Universal Robot internal power supply to 24V in the I/O tab of the Universal Robot GUI.
8. Vacuum On/Off: Tool Output I Digital 0
9. Part present:
  - » Vacuum switch: Tool Input I Digital 0
  - » Vacuum sensor: Tool Input I Analog in[3]
10. Set Vacuum Switch: With the tool active and holding the product, use setpoint adjustment tool to adjust the sensing trimmer to set the "ON" vacuum level. Rotate clockwise to increase the vacuum setpoint; rotate counter-clockwise to decrease the setpoint. The red LED will light when switch is on.
11. Vacuum Sensor: Provides a 1-5V analog output to the I/O. Contact factory for assistance with configuring the robot to respond to this signal.

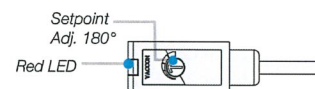

\* Clean dry air is required to prevent damage to tool.

## Set-up - Aubo Robotics

1. Mount the tool to the robot wrist using the four (4) mounting bolts supplied.
2. Ensure the I/O cable can reach the Tool I/O connector on the wrist.
3. Connect the M8 connector to the Tool I/O connector on the Aubo Robot.
4. Connect the 3/8" polyurethane tube to the tool.
5. Route and secure the tubing along the length of the robot ensuring enough slack to allow the robot to move freely.
6. Connect tubing to a filtered and regulated air supply set to 60 or 80 PSI depending on tool.\*
7. The Collaborative Robot Vacuum Tool uses the Aubo Tool I/O to control the tool. All configuration is done in the Aubo Graphical User Interface (GUI).
  - » Set pin 2 power to DC 24V
  - » Set T\_DI/O\_02 to Digital Output - Vacuum On/Off,
  - » Set T\_DI/O\_03 to Digital Input - Part Present Switch
8. Set Vacuum Switch: With the tool active and holding the product, use setpoint adjustment tool to adjust the sensing trimmer to set the "ON" vacuum level. Rotate clockwise to increase the vacuum setpoint; rotate counter-clockwise to decrease the setpoint. The red LED will light when switch is on.
  - » T\_AI\_00 is used when tool has an Analog Vacuum Sensor
9. Vacuum Sensor: Provides a 1-5V analog output to the I/O. Contact factory for assistance with configuring the robot to respond to this signal.

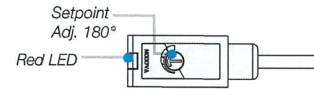

\* Clean dry air is required to prevent damage to tool.

## Set-up - Rethink Robotics

1. Mount the tool to the robot wrist using the four (4) mounting bolts supplied.
2. Ensure the I/O cable can reach the Tool I/O connector on the wrist.
3. Connect the M12 connector to the ClickSmart™ plate
4. Connect the 3/8" polyurethane tube to the tool.
5. Route and secure the tubing along the length of the robot ensuring enough slack to allow the robot to move freely.
6. Connect tubing to a filtered and regulated air supply set to 60 or 80 PSI depending on tool.\*
7. The Collaborative Robot Vacuum Tool uses the Rethink ClickSmart™ Plate to control the tool. All configuration is done using the inertia software.
8. Vacuum On/Off - A\_out2 or B\_out2
9. Part present:
  - » Vacuum switch - A\_in1 or B\_in1
  - » Vacuum sensor - A\_analog\_in or B\_analog\_in
10. Refer to inertia software manual for detailed configuration instructions.
11. Set Vacuum Switch: With the tool active and holding the product, use setpoint adjustment tool to adjust the sensing trimmer to set the "ON" vacuum level. Rotate clockwise to increase the vacuum setpoint; rotate counter-clockwise to decrease the setpoint. The red LED will light when switch is on.
12. Vacuum Sensor: Provides a 1-5V analog output to the I/O. Contact factory for assistance with configuring the robot to respond to this signal.

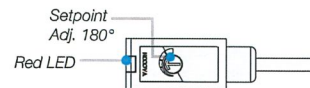

\* Clean dry air is required to prevent damage to tool.

# How To Specify

## Vacuum Port Layout

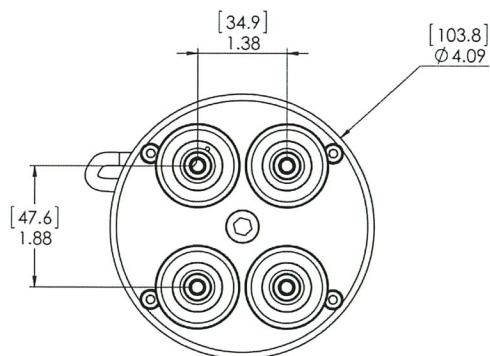

## Dimensional Drawing

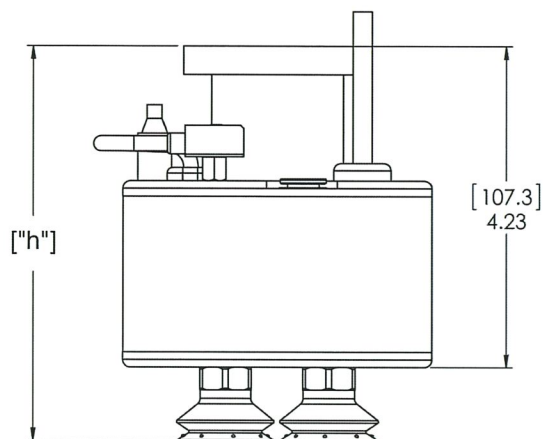

	Height "h" [mm]	Weight lb [kg]
0000	4.23 [107.3]	1.9 [0.86]
1DSB	5.67 [144.1]	2.0 [0.91]
4DSB	5.20 [132.0]	2.1 [0.95]
1SFL	5.78 [146.8]	2.1 [0.95]
4SFL	4.92 [125.0]	2.0 [0.91]

## Operating Ranges

Temperature ranges for normal operation of end effector.

Cup	Working temperature
0000	14° F to 140° F (-10° C to 60° C)
1DSB	50° F to 122° F (10° C to 50° C)
4DSB	50° F to 122° F (10° C to 50° C)
1SFL	14° F to 140° F (-10° C to 60° C)
4SFL	14° F to 140° F (-10° C to 60° C)



## Cups

Although extremely flexible, the standard cup options for the CRVT may not be the best solution for an application. The CRVT can be purchased with no cups. This option offers one (1) 1/4-18 NPT vacuum port in the center of the tool and (4) 1/8-27 NPT vacuum ports near the edge of the tool. These ports can be used to mount the wide variety of cups offered by Bimba. Adapters may be required. The use of reducers may affect performance. Contact customer service for assistance choosing the correct tool and cup combination for your application.



# How to Order

The model number of the Collaborative Robot Vacuum Tool consists of an alphanumeric cluster designating product series, robot type, maximum flow level, maximum vacuum level, operating pressure, switch/sensor option, and cup configuration, which together make up the complete part number to use in ordering. Use the ordering information below to build a valid part number.

An example of a basic CRVT unit with high flow, 28" maximum vacuum, 80 PSI operating pressure, a PNP switch, and quad polyurethane cups is shown below.

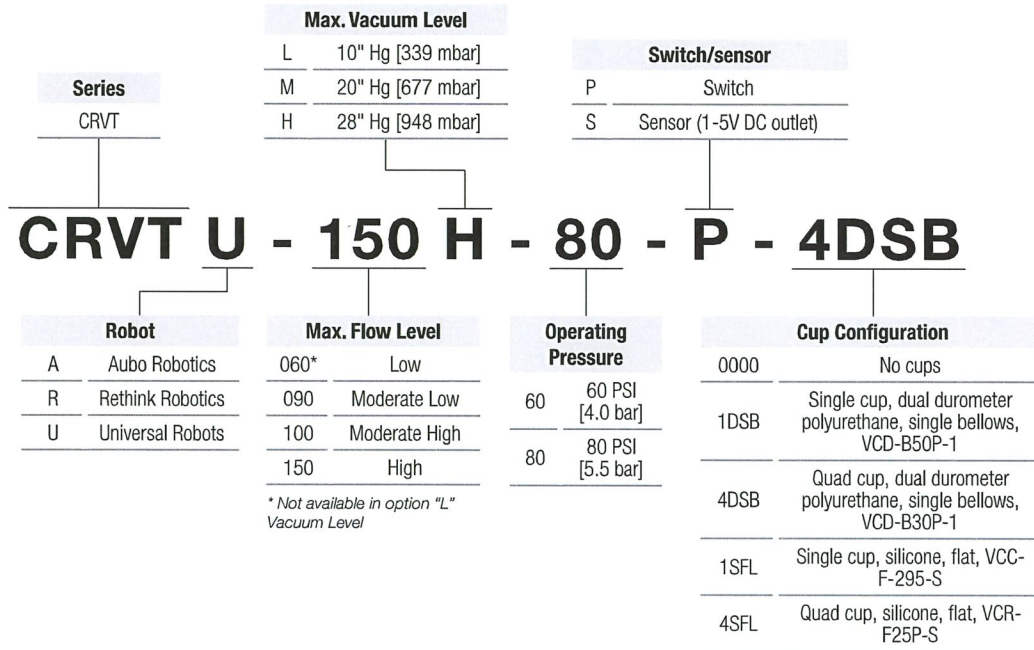

CRVT□-150M-80-P-#### recommended for semi-porous applications  
 CRVT□-100H-80-P-#### recommended for non-porous applications  
 Consult factory for assistance choosing the correct vacuum characteristics for your application

## Custom Vacuum Ports

---

The bottom plate of the CRVT has five (5) vacuum ports standard. The ports are positioned to provide maximum flexibility. In some cases, additional ports or different threads may be required. Contact customer service for assistance developing a custom vacuum plate to optimize the performance of the CRVT for your application.

## Custom Mounting Plates

---

The number of collaborative robots on the market continues to grow. The standard CRVT mounting plate is compatible with robots using the ISO 9409-1-50-4-M6 bolt pattern. Other patterns may be required. The CRVT is designed to allow custom mounting plates to be added to the tool, enabling it to mount to different bolt patterns. Contact Bimba customer service for assistance adapting the CRVT to your robot.

For further customization, contact the factory.

IMI Precision Engineering operates four global centres of technical excellence and a sales and service network in 75 countries, as well as manufacturing capability in the USA, Germany, China, UK, Switzerland, Czech Republic, Mexico and Brazil.

For information on all IMI Precision Engineering companies visit

[www.imi-precision.com](http://www.imi-precision.com)

**Supported by distributors worldwide.**



Due to our policy of continuous development, Bimba reserve the right to change specifications without prior notice.

BIM-CRVTC-0518

Selected Images used under license from Shutterstock.com

**Bimba**

25150 S. Governors Hwy  
University Park, IL 60484

Tel: +1 708 534 8544

Fax: +1 708 235 2014

For further information, scan this QR code or visit [www.bimba.com](http://www.bimba.com)

