

### COMPONENT LIST

Quantity	PART#	REV	ID
2	OUTER-C SIDES	A	SIDES, CORRUGATED SHEET, KRAFT, C-FLUTE, 108.5" X 49" SCORED AT 30" EACH END
2	OUTER-C T&B	A	TOP AND BOTTOM CORRUGATED COVER, KRAFT, C-FLUTE, 63.5" X 60", SCORED AT 5" EACH SIDE
1	PALLET		48" X 40" PALLET
1	F-6 PANNEL	A	6 PANNEL EPS, 1.5# DENSITY , T&B: 52.000 X 47.000 X 2.000, SIDES: 52.000 X 45.000 X 2.000, ENDS: 43.000 X 45.000 X 2.000

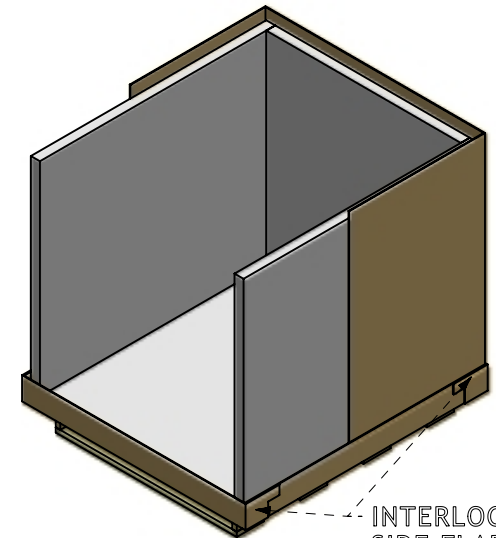
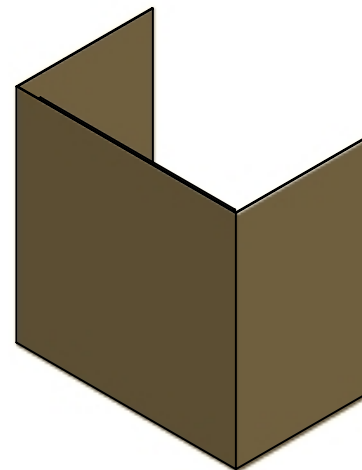
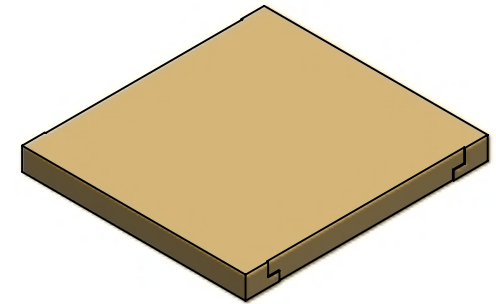
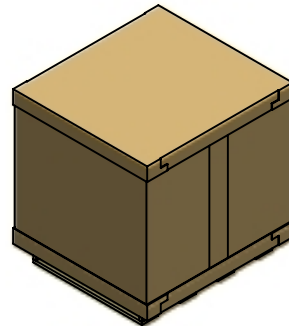
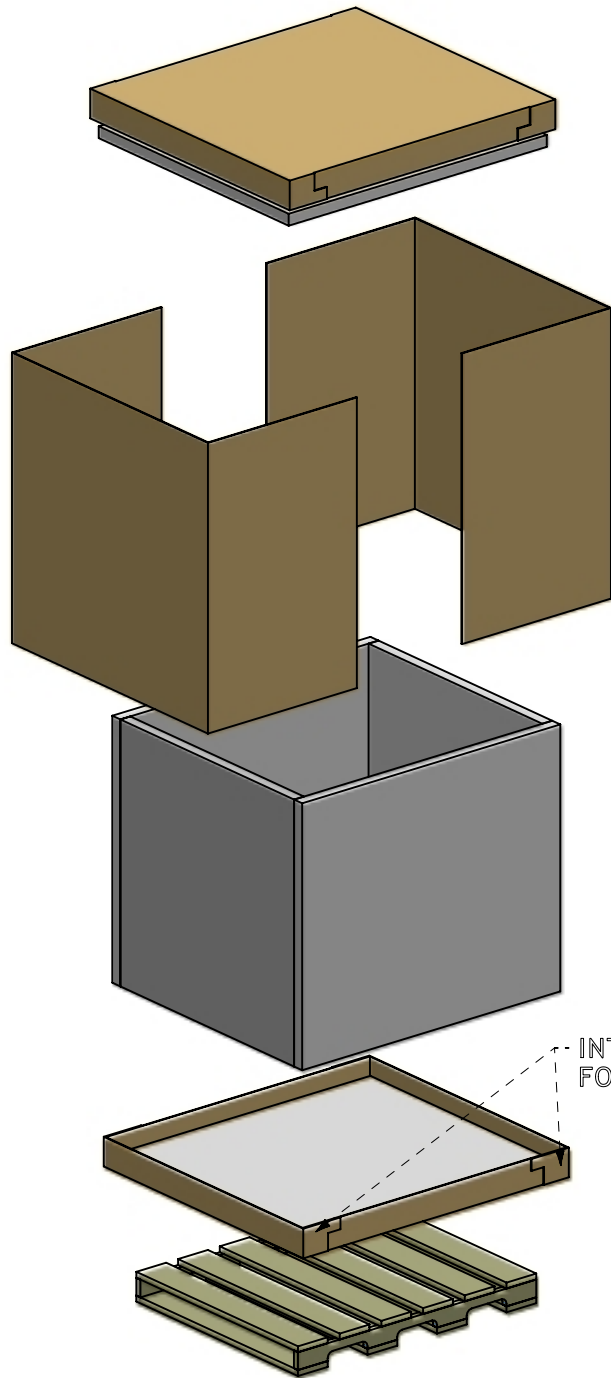

INTERLOCKING SIDE FLAPS FOR EASY ACCESS

INTERLOCKING SIDE FLAPS

REVISIONS			
REV	REV. DATE	DCO	DESCRIPTION



DRAWN: MKA	CHECKED: -	Packaging Technology Group 565 Commerce Drive Fall River, MA 02720	PLANT
UNLESS OTHERWISE SPECIFIED TOLERANCES 2 PLACES : .01 3 PLACES : .005 ANGLES : 1/2 FRACTIONS : 1/16	QA APPROVAL: -	DO NOT SCALE DRAWING	0-0-0
THIS DRAWING AND INFORMATION CONTAINED THEREON ARE CONFIDENTIAL AND THE PROPERTY OF PACKAGING TECHNOLOGY GROUP. ANY OTHER USE OR REPRODUCTION OF THIS DRAWING IS EXPRESSLY PROHIBITED WITHOUT PACKAGING TECHNOLOGY GROUP CONSENT.		ENG#: 004-021 OP1	REV #: A
DWG NUMBER: PALLET CONFIG			