

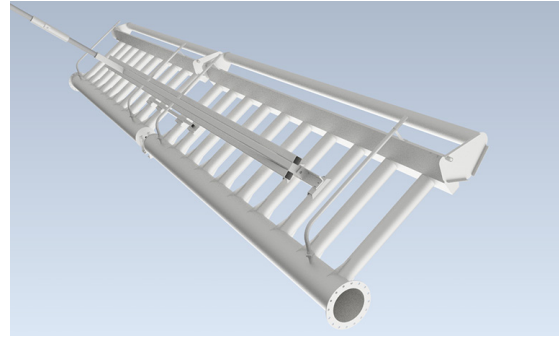

Armor ABJ is a leading manufacturer of stainless-steel decanters

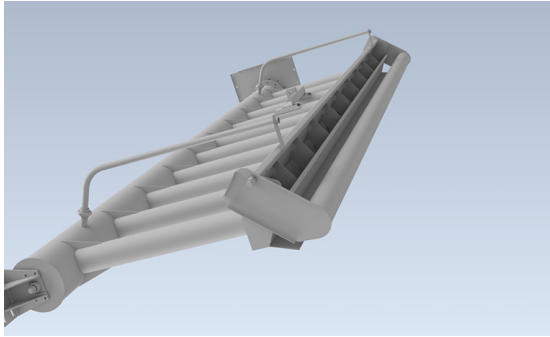

End Wall Titrating Trough Decanter

Designs based on detailed stress analysis

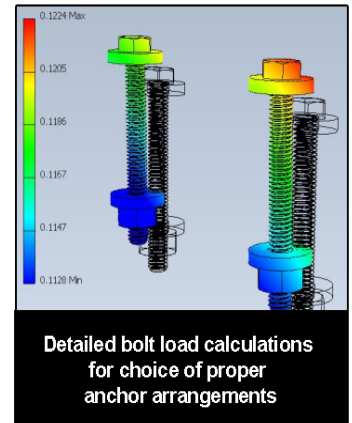
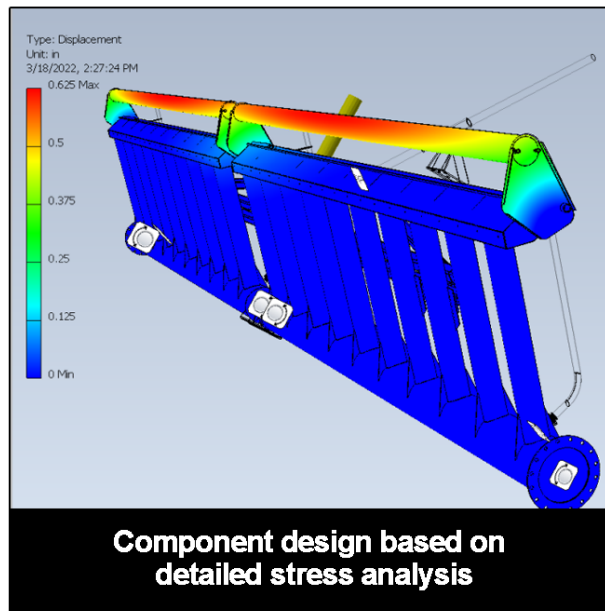
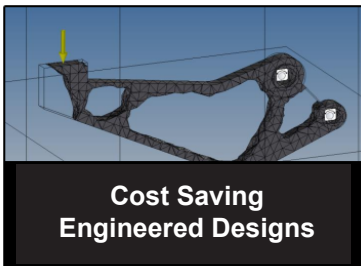

Other Build Features:

- Stainless steel 304L and 316 construction
- In-house engineering
- Designs based on detailed stress analysis
- Custom sizes, 4' to 40' weir length
- Leak free swivel joints built in-house
- Single and dual decanter designs
- Fully passivated
- Shape optimized bracket
- Accurate bolt loads for anchor selection
- Rugged efficient design



Contact us today

4600 N. Mason-Montgomery Road | Mason, OH 45040 | 513-923-5600 | sales@TheArmorGroup.com

www.ArmorABJ.com

