

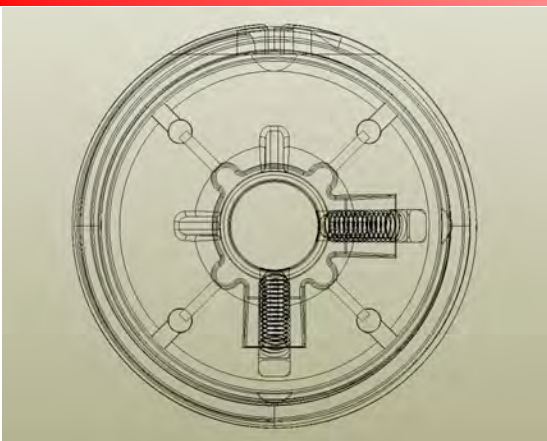















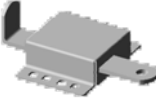

Guardian—Your home to quality garage door components



www.adhguardianusa.com



	CABLE DRUMS.....	3
	SPRING FITTINGS.....	6
	SHAFT KEY	8
	ROLLERS.....	9
	HINGES.....	12
	BRACKETS.....	16
	SAFETY DEVICES.....	20
	ROLLER DOOR PARTS.....	22
	LOCKS & HANDLES.....	23
	BEARINGS & PULLEYS.....	26
	SHAFT COUPLERS.....	28
	COLLARS	30
	HOISTS.....	31
	MISCELLANEOUS	33
	DOOR OPENERS.....	37
	COMPANY PROFILE	45

400-8

- Max. door height: 8 feet (2440mm)
- Capacity: 265 lbs (120kgs) per drum
- Max. cable size: 1/8" (3mm)
- Set screws: 1" x2pcs installed
- LH/RH I.D. and Color Coded
- Recommended for 1" tubing only

0.43kg/pair
 100
 3200

400-13

- Max. door height: 13 feet (3960mm)
- Capacity: 375 lbs (170kgs) per drum
- Max. cable size: 1/8" (3mm)
- Set screws: 1" x 2pcs installed
- LH/RH I.D. and Color Coded
- 1/4" keyway & use on 1" shaft

0.79kg/pair
 60
 1800

525-18

- Max. door height: 18 feet (5500mm)
- Capacity: 500 lbs (227kgs) per drum
- Max. cable size: 1/16" (4.8mm)
- Set screws: 1" x 3pcs installed
- LH/RH I.D. and Color Coded
- 1/4" keyway & use on 1" shaft

1.6kg/pair
 30
 960

800-32

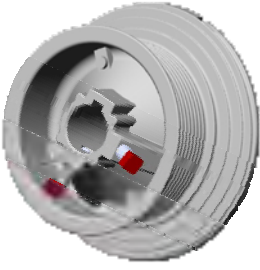
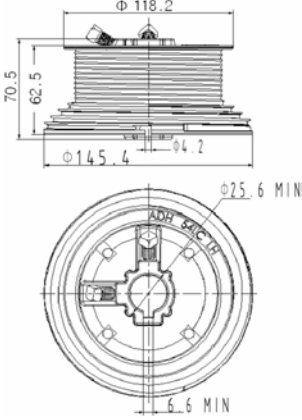

- Max. door height: 32feet (9750mm)
- Capacity: 1,000bs (455kgs) per drum
- Max. cable size: 1/16" (4.8mm)
- Set screws: 1" x 3pcs installed
- LH/RH I.D. and Color Coded
- 1/4" keyway & use on 1" shaft

6.5kg/pair
 4
 240

400-54



- Max. door height: 10' 3" + high lift
- Max. high lift: 54" (1370mm)
- Capacity: 275 lbs (125kgs) per drum
- Max. cable size: 1/8" (3mm)
- Set screws: 1" x 2pcs installed
- LH/RH I.D., Color Coded & 1/4" keyway

 0.93kg/pair
 60
 1440

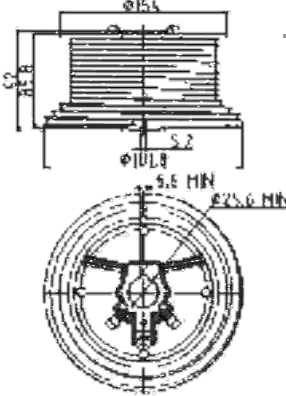
525-54



- Max. door height: 15' 3" + high lift
- Max. high lift: 54" (1370mm)
- Capacity: 500 lbs (227kgs) per drum
- Max. cable size: 3/16" (4.8mm)
- Set screws: 1" x 2pcs installed
- LH/RH I.D., Color Coded & 1/4" keyway

 1.86kg/pair
 30
 720

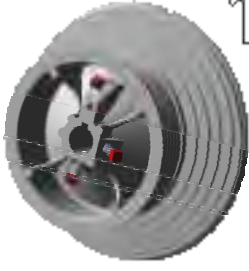
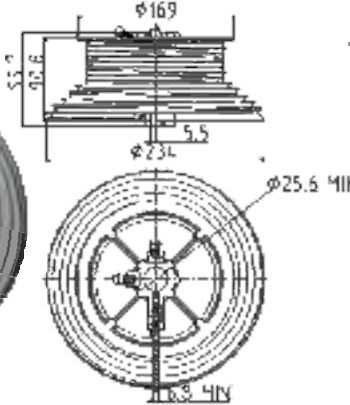
575-120



- Max. door height: 12' 6" + high lift
- Max. high lift: 120" (3050mm)
- Capacity: 500 lbs (227kgs) per drum
- Max. cable size: 3/16" (4.8mm)
- Set screws: 1" x 3pcs installed
- LH/RH I.D., Color Coded & 1/4" keyway

 2.3kg/pair
 20
 480

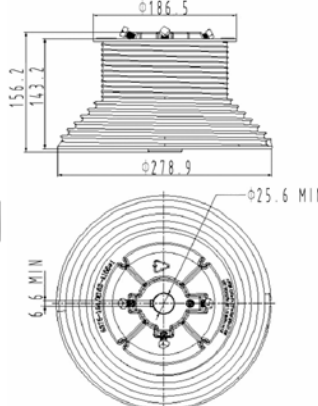
638-164

- Max. door height: 19' 6" + high lift
- Capacity: 800 lbs(363kgs) per drum
- Max. cable size: 1/4"
- Set screws: 1" installed
- LH/RH I.D., Color Coded & 1/4" keyway

 7.3kg/pair
 4
 192



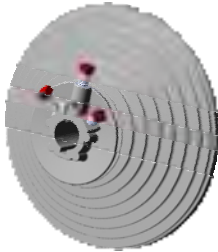
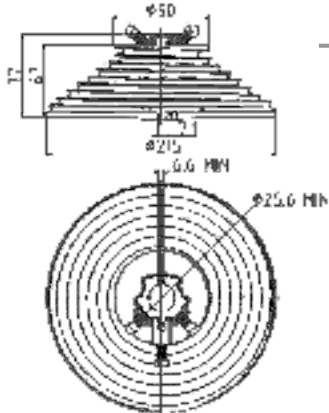

143-11

- Max. door height: 11 feet (3350mm)
- Capacity: 425 lbs (193kgs) per drum
- Max. cable size: 3/16" (4.8mm)
- Set screws: 1" installed
- LH/RH I.D. and Color Coded
- 1/4" keyway & use on 1" shaft

 1.7kg/pair

 30

 900

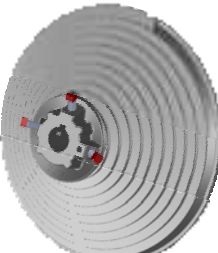
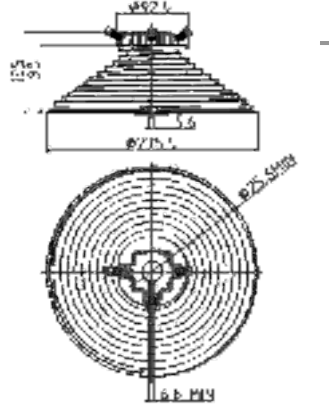



1100-18

- Max. door height: 18 feet (5480mm)
- Capacity: 500 lbs. (227kgs) per drum
- Max. cable size: 3/16" (4.8mm)
- Set screws: 1" x 3pcs installed
- LH / RH I.D. and Color Coded
- 1/4" keyway & use on 1" shaft

 3.36kg/pair

 4

 192

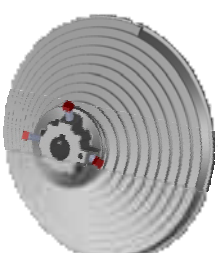
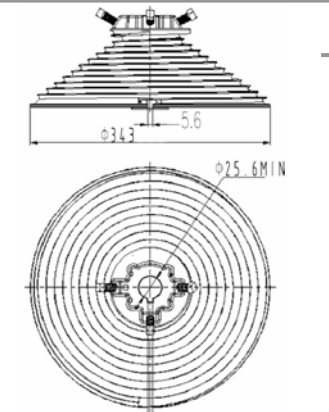



348-28

- Max. door height: 28feet (8524mm)
- Capacity: 700lbs. (317kgs) per drum
- Max. cable size: 3/16" (4.8mm)
- Set screws: 1" x 3pcs installed
- LH / RH I.D. and Color Coding
- 1/4" keyway & use on 1" shaft

 8.7kg/pair

 2

 48

SPRING FITTINGS

SF 175

- 2 pcs/set
- Winding & stationary packed separately
- Set screws installed
- Max. wire: 0.295"
- Supplied without keyway
- Color coded

0.18/0.1kg/pc
 100/200
 6,000/10,800

SF 200

- 2 pcs/set
- Winding & stationary packed separately
- Set screws installed
- Max. wire: 0.295"
- Supplied without keyway
- Color coded

0.1/0.21kg/pc
 80/160
 5,760/7,200

SF 263

- 2 pcs/set
- Winding & stationary packed separately
- Set screws installed
- Max. wire: 0.331"
- Supplied without keyway
- 4 keyways available
- Color coded

0.16/0.28kg/pc
 150/100
 4,500/6,000

SF 375-SS

- 4 pcs/set
- Winding & stationary packed separately
- Set screws installed
- 1" bore standard, 1-1/4" bore available
- Max. wire: 0.406"
- Supplied without keyway
- 4 keyways available
- Color coded

0.21/0.3kg/pc
 45/90
 2,700/1,200

SPRING FITTINGS

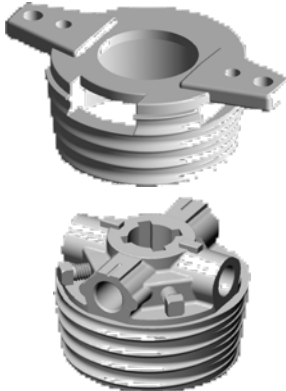

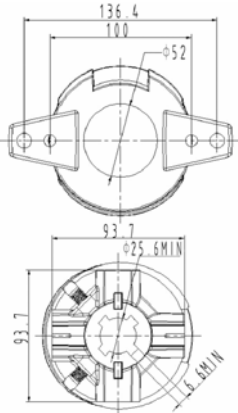



SF 375-SL

- Universal thread for LH or RH 3 3/4" torsion springs
- Each set contains 1 pc. winding 1 pc. stationary
- Max. wire: 0.406"
- Set screws: 1.5" x 2pcs installed
- Designed for use on 1" solid shaft
- Color Coded
- 4pcs/set

 0.6/0.3kg/pc

 45/90

 2,050/2,700

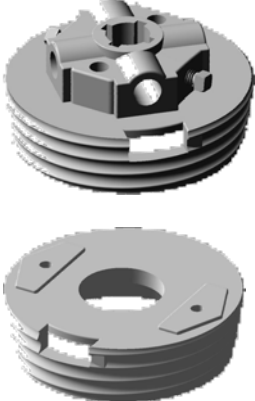

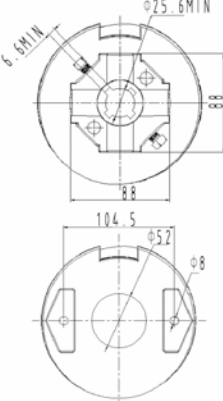



SF 525

- For use on 5 1/4" I.D. torsion springs
- Individually threaded - RH or LH
- Each set contains 2 pcs. winding / 2 pcs. stationary
- Max. wire size: 0.437"
- Set screws: 1.5" x 2pcs installed
- LH/RH I.D. and color-Coded
- Designed for use on 1" solid shaft
- 4pcs/set

 0.775/0.6kg/pc

 30/60

 1,200/1,920



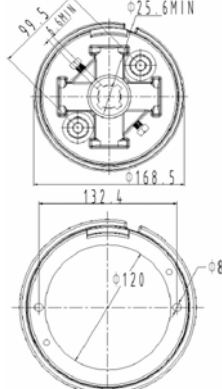



SF 600

- For use on 6" I.D. torsion springs
- Individually threaded - RH or LH
- Each set contains 2 pcs. winding 2 pcs. stationary
- Max. wire size: 0.437"
- Includes 2 bearing retaining plates per set
- Set screws: 1.5" x 2pcs installed
- LH/RH I.D. and color-Coded
- Designed for use on 1" and 1-1/4" steel shaft
- 4pcs/set

 0.9/0.47kg/pc

 30/60

 900/1,800

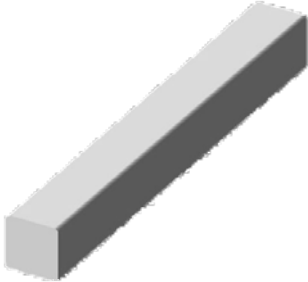

SHAFT KEYS

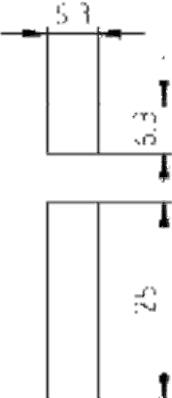





KY 1401

- Straight Key
- 1" x 1/4" x 1/4"
- Zinc plated
- For standard 1/4" keyway
- 3" available

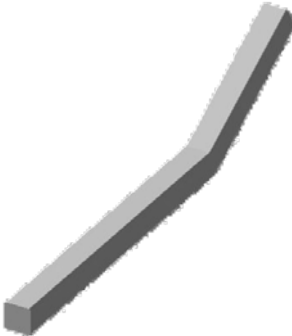

 0.008kg/m
 2,000
 150,000





KY 1403

- Bend Key
- 3-3/4 x 1/4" x 1/4"
- 30° bend x 3/4" long
- Zinc plated
- For standard 1/4" keyway

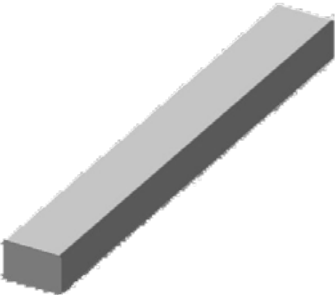

 0.036kg/m
 600
 30,000

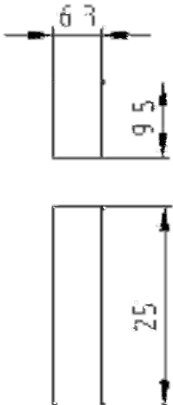



KY 3801

- Straight High Key
- 1" x 1/4" x 3/8"
- Zinc plated
- For tubular shaft with keyway
- 3" available

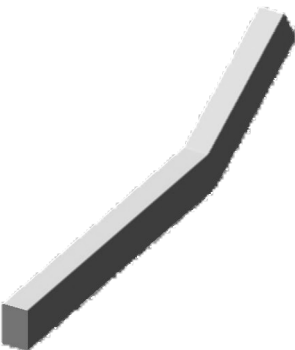

 0.012kg/m
 1,800
 90,000

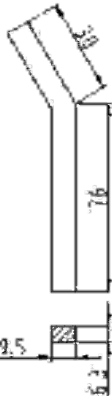



KY 3813

- Bend High Key
- 3-3/4 x 1/4" x 3/8"
- 30° bend
- Zinc plated
- For tubular shaft with keyway

 0.054kg/m
 400
 20,000

BR 2004

2" Residential Nylon Roller

- Nylon roller
- 4" zinc plated stem
- Bulged shoulder
- Solid stem
- Rating:50-lbs load
- 10,000 x 8' Door cycles

0.11kg/pc
 150
 7,200

BR 2004K

2" Residential Nylon Roller

- Nylon roller
- 4" zinc plated stem
- Bulged shoulder
- Tubular stem
- Rating:50-lbs load
- 10,000 x 7' Door cycles

0.052kg/pc
 150
 7,200

BR2074

2" 7-Ball Roller

- 7-Ball
- 4" stem
- Bulged shoulder
- Rating:35-lbs load
- 10,000 x 8' Door cycles

0.132kg/pc
 150
 7,200

BR2104

2" 10 Ball Roller Short Stem

- 10-ball
- Hardened
- 4" stem
- Bulged shoulder
- Rating:75-lbs load
- 15,000 x 12' Door cycles

0.153kg/pc
 150
 7,200

BR2107

2" 10 Ball Roller Long Stem

- 10-ball
- Hardened
- 7" stem
- Bulged shoulder
- Rating:75-lbs load
- 15,000 x 12' Door cycles

0.207kg/pc
 100
 4,800

BR2114

2" Commercial Nylon Roller

- 11-ball
- Hardened
- 4" stem
- Bulged shoulder
- Rating:75-lbs load
- 15,000 x 12' Door cycles

0.145kg/pc
 150
 7,200

BR2115

2" Commercial Nylon Roller

- 11-ball
- Hardened
- 4.5" stem
- Bulged shoulder
- Rating:75-lbs load
- 15,000 x 12' Door cycles

0.173kg/pc
 150
 7,200

BR2117

2" Commercial Nylon Roller Long

- 11-ball
- Hardened
- 7" stem
- Bulged shoulder
- Rating:75-lbs load
- 15,000 x 12' Door cycles

0.198kg/pc
 100
 4,800

BR3104

3"-5" Stem Roller

- 10-ball
- For 3" track
- Hardened
- Bulged shoulder
- Rating: 150-lbs load
- 50,000 x 12' Door cycles

0.317kg/pc
 60
 2,880

BR3107

3" – 7" Stem Roller

- 10 - ball
- For 3" track
- 7" stem
- Hardened
- Bulged shoulder
- Rating: 150-lbs load
- 50,000 x 12' Door cycles

0.364kg/pc
 60
 2,880

BR3109

3" – 9" Stem Roller

- 10-ball
- 9" stem
- Hardened
- Staked shoulder
- Rating: 150-lbs load
- 50,000 x 12' Door cycles

0.41kg/pc
 50
 2,400

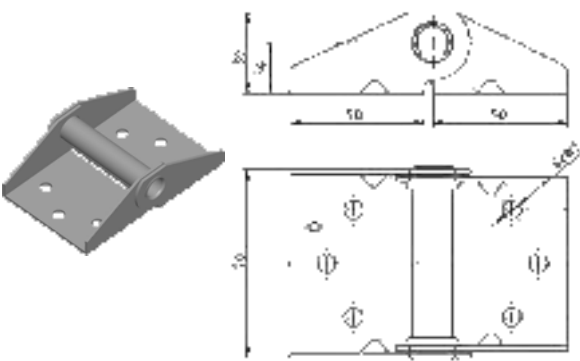



Technical drawings for HG 1400 hinge showing a 3D perspective view, a top view with dimensions (10, 50, 50, 15), and a side view with dimensions (15, 15).

HG 1400

- 14 gauge steel
- Zinc plated
- For regular single skin door panel

 0.1kg/pc

 50

 2,000

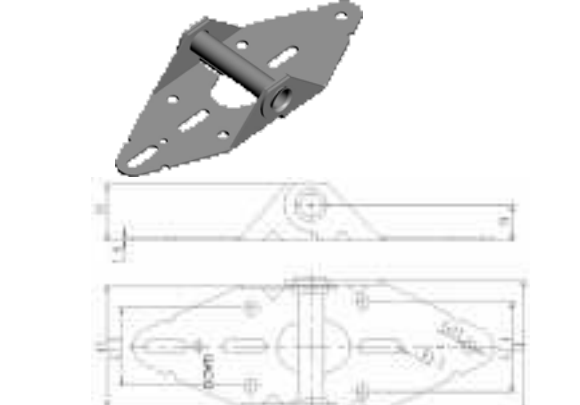



Technical drawings for HG 1401 hinge showing a 3D perspective view, a top view with dimensions (10, 50, 50, 15), and a side view with dimensions (15, 15).

HG 1401

- 14 gauge steel
- Zinc plated
- For regular sandwich door panel

 0.17kg/pc

 100

 2,000

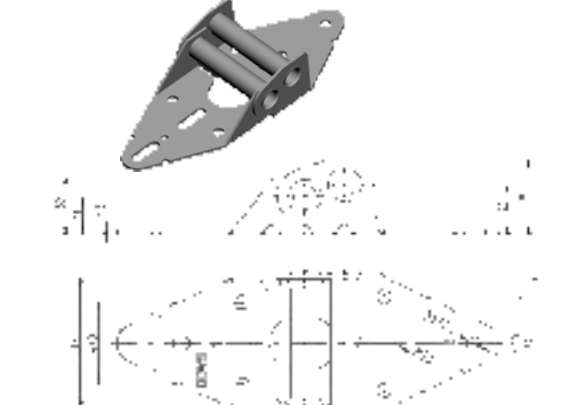



Technical drawings for HG 1402 hinge showing a 3D perspective view, a top view with dimensions (10, 50, 50, 15), and a side view with dimensions (15, 15).

HG 1402

- 14 gauge steel
- Zinc plated
- For standard roller stem

 0.23kg/pc

 100

 2,000

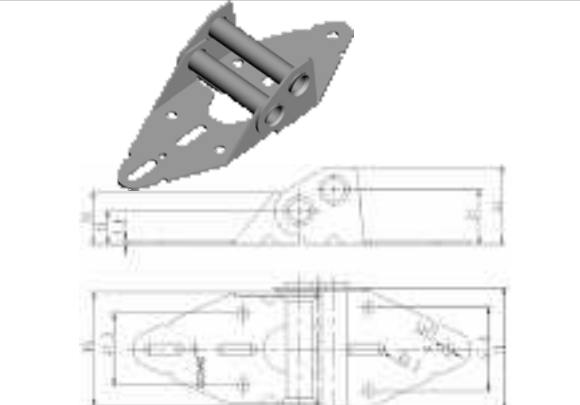



Technical drawings for HG 1403 hinge showing a 3D perspective view, a top view with dimensions (10, 50, 50, 15), and a side view with dimensions (15, 15).

HG 1403

- 14 gauge steel
- Zinc plated
- For standard roller stem

 0.24kg/pc

 100

 2,000

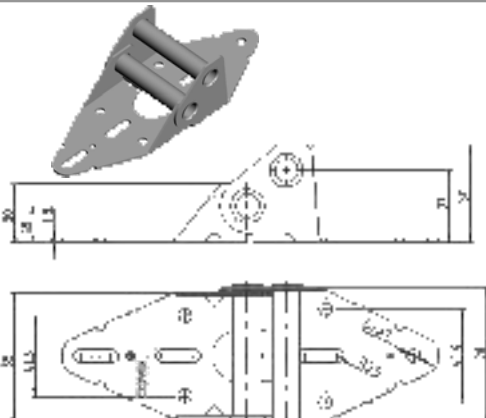

HG 1404

- 14 gauge steel
- Zinc plated

 0.23kg/pc

 80

 2,000

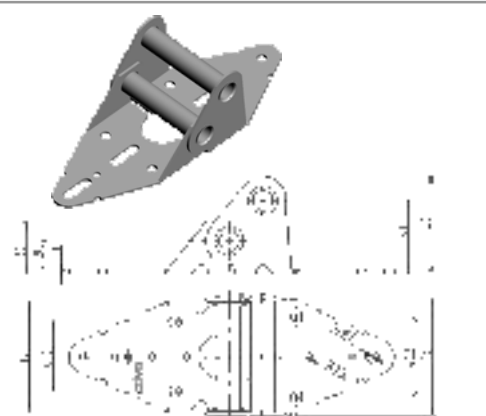

HG 1405

- 14 gauge steel
- Zinc plated

 0.24kg/pc

 60

 2,000

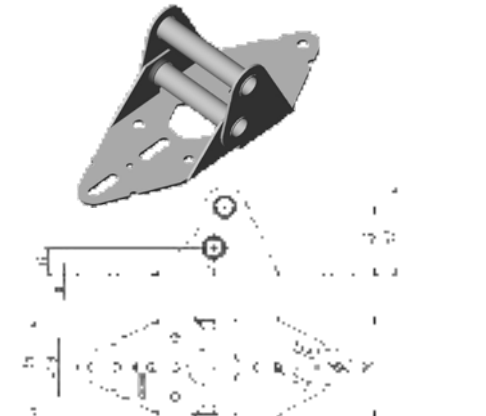

HG 1406

- 14 gauge steel
- Zinc plated

 0.23kg/pc

 50

 2,000

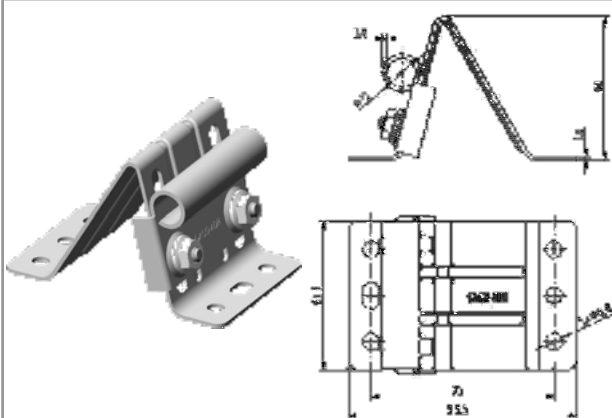



SP 3980

Residential Top Bracket

- 15 gauge steel base
- 14 gauge steel roller carrier
- Bright zinc plated
- For standard roller stem

 0.21kg/pc

 100

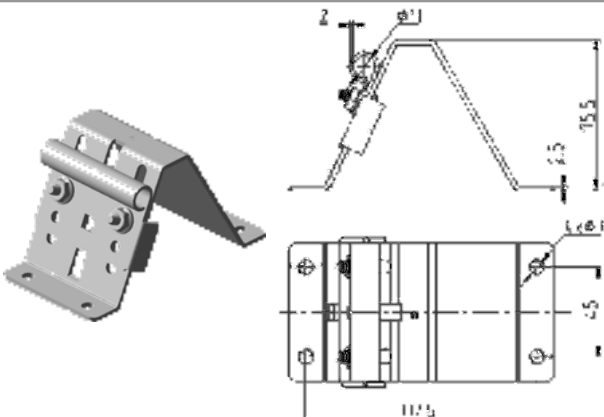

 1500



SP 3981

Commercial Top Bracket

- 12 gauge steel base
- 14 gauge steel roller carrier
- Zinc plated
- For standard stem roller

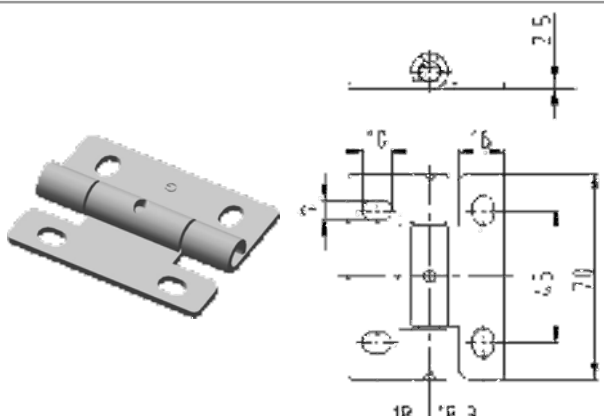

 0.32kg/pc
  25
  1,500



HC 2516

Center Hinge

- 12 gauge steel
- Zinc plated
- For residential pinch free door
- 18mm center line (3/4")

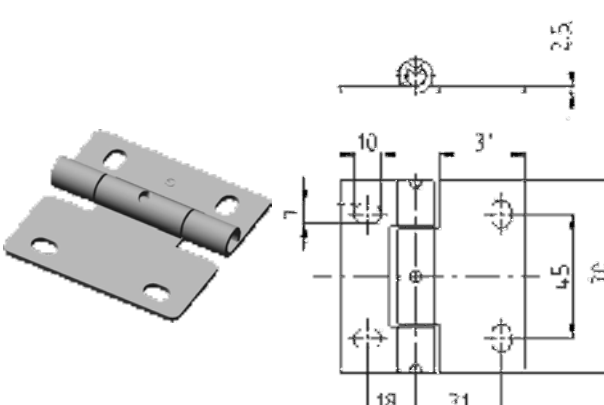

 0.11kg/pc
  100
  10,800



HC 2531

Center Hinge

- 12 gauge steel
- Zinc plated
- For residential pinch free door
- 31mm center line (1-1/2")

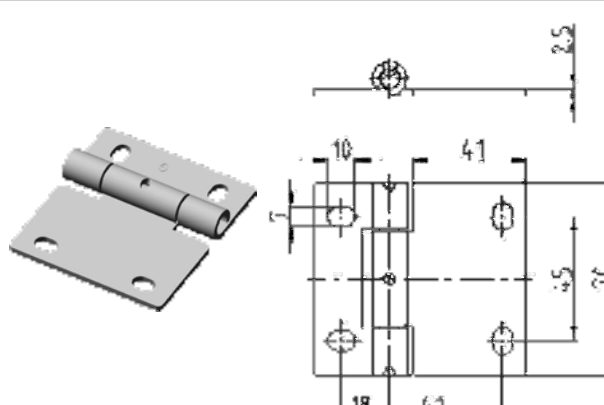

 0.12kg/pc
  150
  10,800



HC 2541

Center Hinge

- 12 gauge steel
- Zinc plated
- For residential pinch free door
- 41mm center line (1-5/8")

 0.14kg/pc
  200
  10,800

HS 2516

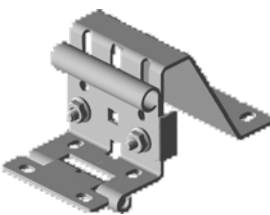
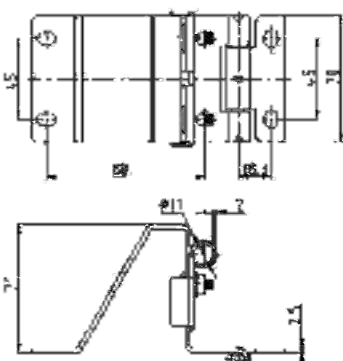
- 12 gauge steel
- Zinc plated
- Side hinge for pinch free door

 0.1kg/pc

 50

 1,800

HS 2531

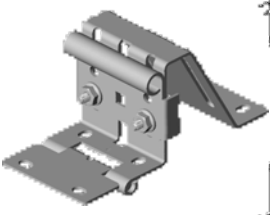
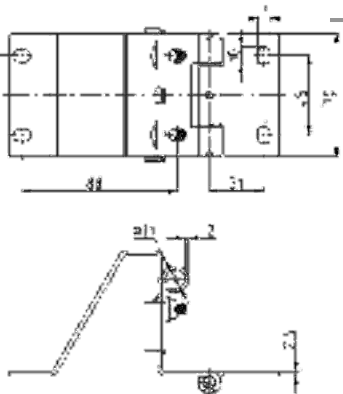
- 12 gauge steel
- Zinc plated
- Side hinge for pinch free door

 0.13kg/pc

 60

 1,800

HS 2541

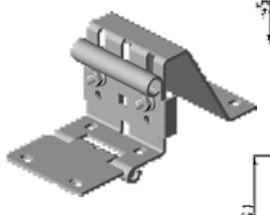
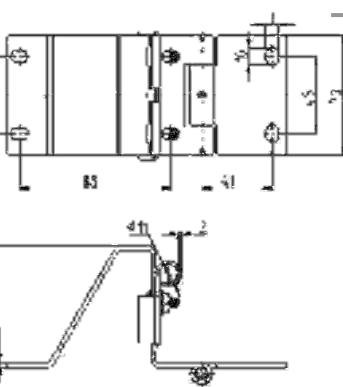
- 12 gauge steel base
- Bright zinc plated
- Side hinge for pinch free door

 0.5kg/pc

 40

 1,800

FB 1201

Universal Decorator (Flag angle)

- 12 gauge steel
- Zinc plated
- For 12" radius track

0.65kg/pc

20

200

JB 1106

12 GA Jamb Bracket

- 12 gauge steel
- Zinc plated

0.156kg/pc

150

7,200

JB 1108

12 GA Jamb Bracket

- 12 gauge steel
- Zinc plated

0.168kg/pc

150

7,200

JB 1110

12 GA Jamb Bracket

- 12 gauge steel
- Zinc plated

0.181kg/pc

150

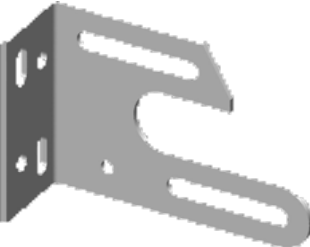
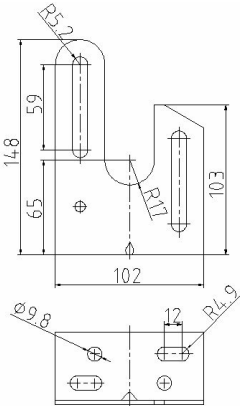

7,200





CB 1100

Universal Spring Anchor

- 11 gauge steel base
- Bright zinc plated
- Universal adjustable wall center
- Suitable for 1" bearing

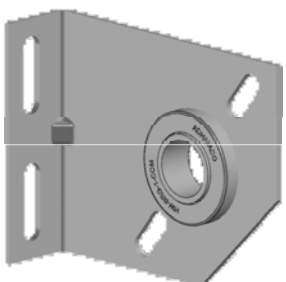
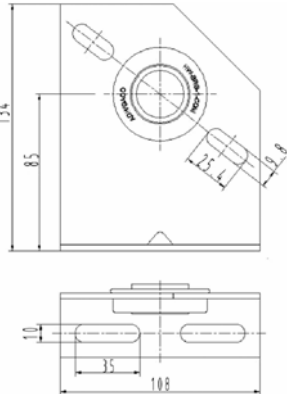

 0.4kg/pc
 90
 4320





CB 1100L

Center Bearing support

- Zinc plated
- Wall center 3-3/4"
- Heavy duty bearing installed

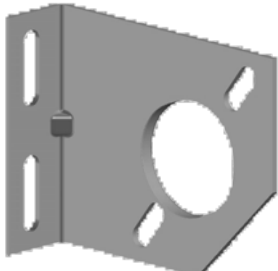
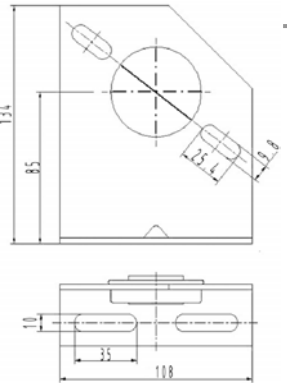

 0.42kg/pc
 50
 3000





CB 1101

Spring Anchor

- Zinc plated
- Wall center 3-3/4"
- Option with open bearing slot

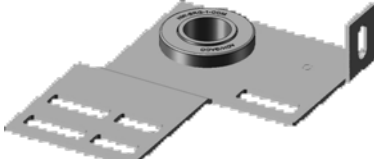
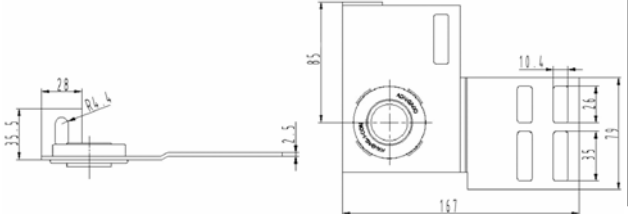

 0.33kg/pc
 80
 4800

EB 0011

End Bearing Flanged

- 12 gauge steel
- Zinc plated
- Heavy duty bearing installed

 0.37kg/pc
 80
 3200

BB 0300

Adjustable Aluminum Bottom Bracket

- Suitable for standard roller stem
- Maximum door weight 1,000lbs
- Adjustable cable tension

1.0kg/pair
 20
 400

BB 1200

12 GA Bottom Bracket

- 12 gauge steel
- Zinc plated
- Suitable for standard roller stem
- Maximum door weight 350lbs

0.52kg/pair
 100
 2,000

BB 1400

12 GA Bottom Bracket for Low Head Room

- 12 gauge steel
- Zinc plated
- Maximum door weight 250lbs

1.15kg/pair
 40
 360

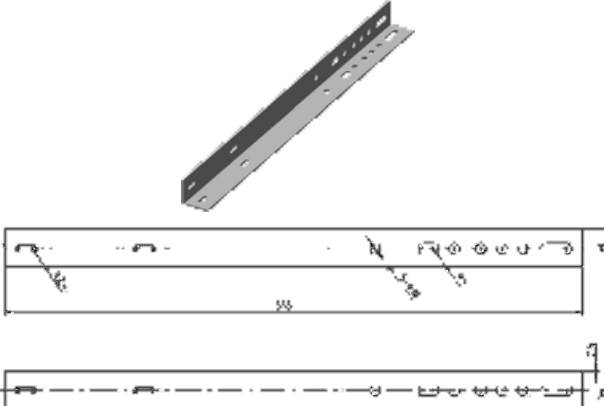



HB 0019

12GA Horizontal Bracket

- 12 gauge steel
- Zinc plated
- Universal hole pitch

 0.725kg/pc

 20

 10,000

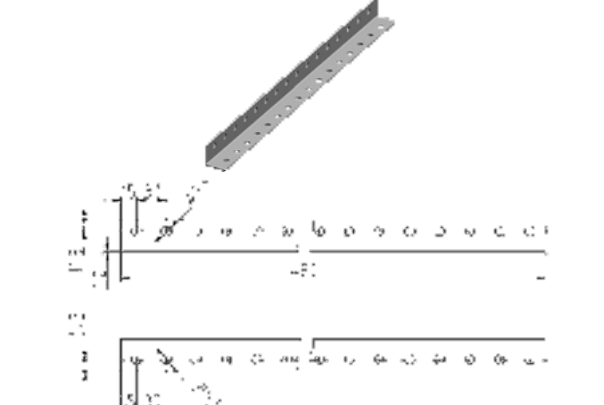

PA 0500

- Perforated angle
- 3/8"round hole x 1-1/4" apart
- 12 gauge steel
- 19" long

 0.25kg/pc

 100

 10,000

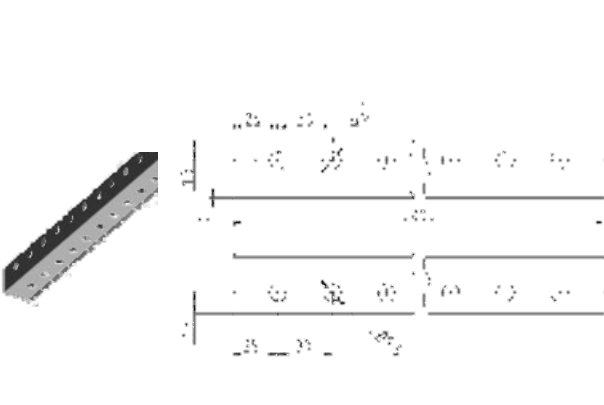

PA 1995

- Perforated angle
- 3/8"round hole x 1-1/4" apart
- 12 gauge steel
- 6'5" long

 1.065kg/pc

 N/A

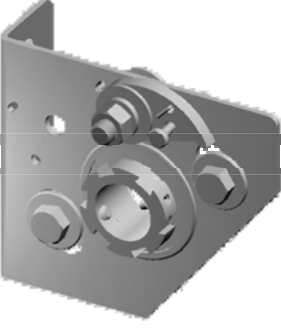
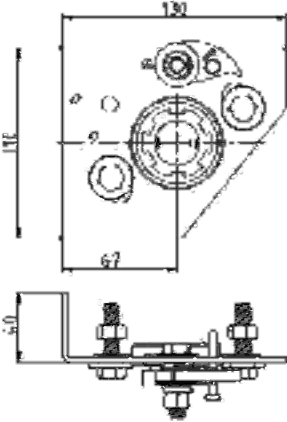

 2,000





SD 175 / 200

Residential Spring Braking Device

- For use with spring fitting SS 175 / SS 200
- Universal adjustable wall center 2-5/8"
- Zinc plated
- Steel coating ratchet wheel

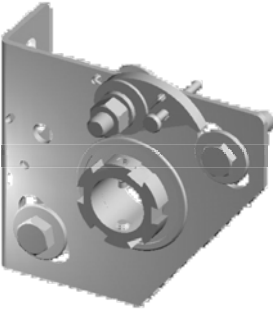
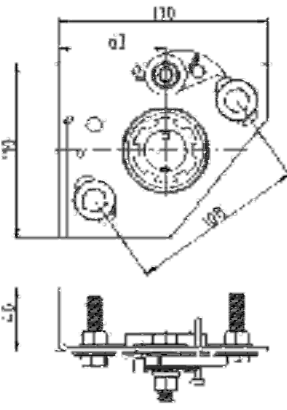

 0.6kg/pc
 35
 735





SD 263

Residential Spring Braking Device

- For use with spring fitting SS 263
- Universal adjustable wall center 2-5/8"
- Zinc plated
- Steel coating ratchet wheel

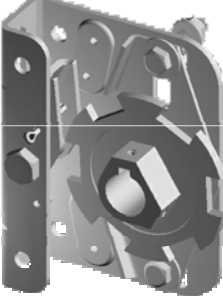
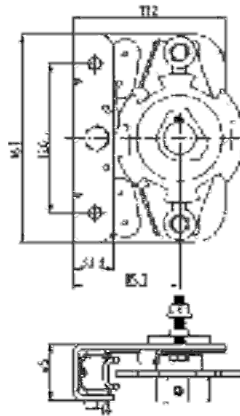

 0.61kg/pc
 35
 735





SD 375

Residential Spring Braking Device

- For use with spring fitting SS 375
- Universal adjustable wall center 3-3/8"
- Zinc plated
- Steel coating ratchet wheel

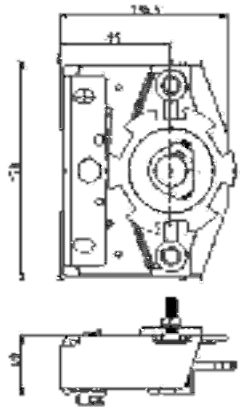

 1.7kg/pc
 20
 100

SD 600

Residential Spring Braking Device

- For use with spring fitting SS 600
- Universal adjustable wall center 3-1/2"
- Zinc plated
- Steel coating ratchet wheel

 2.1kg/pc
 20
 100

BB 0200

2" Safety Device

- European design, premium quality bottom brackets are built to stop and hold a door in the event of a cable failure.
- This device activates when the cables go slack. Some applications may require pusher springs or inclined tracks.

1.74kg/pc
 10
 180

BB 0230

2" Safety Device

- European design, premium quality bottom brackets are built to stop and hold a door in the event of a cable failure.
- This device activates when the cables go slack. Some applications may require pusher springs or inclined tracks.

2.9kg/pc
 6
 180

DW 0001

Drum Wheel

- For curtain roller door
- Rigid plastic

0.38kg/pc
 15
 240

DW 0011

Drum Wheel

- Steel
- Black painting
- Small drum for curtain roller door

0.61kg/pc
 15
 240

RL 0003

Roller Door Lock

- For curtain roller door
- Lock ban available

0.3kg/pc
 35
 3290

RP 0001

Saddle

- Malleable iron
- For use with shaft of 1-5/16" diameter
- U bolt available

0.25kg/pc
 100
 5,000

HSB 001

Hand Slide Shoot Bolt

- D handle design
- Hole for pad lock
- Zinc plated

0.7kg/pc
 20
 720

SP 4000

Slide Lock

- Spring activated lock bar system
- Bright zinc plated steel
- Universal, fits 2" and 3" track

0.41kg/pc
 50
 800

SP 5000

Slide Lock

- Spring activated lock bar system
- Bright zinc plated steel
- Universal, fits 2" and 3" track

0.27kg/pc
 80
 4000

SP 4660

Swivel Latch

- Bright zinc plated steel
- For use with outside keyed handle to operate auto spring latches.

0.125kg/pc
 200
 10,000

SP 5690

Snap latch-(Auto Latch)

- Bright zinc plated steel
- 13 gauge steel base
- 11 gauge steel arm
- 8 lbs force required to open

0.23kg/pc
 100
 2,400

SP 5700

Auto Latch striker

- Bright zinc plated steel
- 14 gauge steel base
- For use with auto spring latches

0.07kg/pc
 300
 15,000

HL 0001

Lift Handle

- Zinc die casting
- Chrome finish

0.053kg/pc
 100
 1,800

SC 7231

Lift Handle

- 14 gauge
- Zinc plated

0.08kg/pc
 100
 1,800

ZT 5160

Keyed T Handle

- Available with exterior mounted base or with interior blind mounted base with screw posts
- Heavy duty wafer cylinder keylock and 2 keys
- 3.5" shaft length
- Bright chrome plated finish
- Clockwise locking rotation

0.26kg/pc
 100
 1,000

ZT 5161

Keyed T Handle

- Available with exterior mounted base or with interior blind mounted base with screw posts
- Heavy duty wafer cylinder keylock and 2 keys
- 3.5" shaft length
- Bright chrome plated finish
- Clockwise locking rotation

0.26kg/pc
 100
 1,000

ZT 5160D / 5161D

Dummy T Handle

- Available with exterior mounted base or with interior blind mounted base with screw posts
- 3.5" shaft length
- Bright chrome plated finish

0.21kg/pc
 100
 1,000

ER 0122

Swivel Latch

- Bright zinc plated steel
- For use with outside keyed handle to operate auto spring latches.

0.17kg/pc
 100
 1,000

BB2011

1" Commercial Bearing

- Flanged diameter: 2 1/8"
- Standard 1" I.D. x 2" O.D.
- Races case hardened
- Grease packed
- Chromate finish

0.11kg/pc
 200
 10,000

BN2011

1" Center Plastic Bearing

- Flanged diameter: 2 1/8"
- Standard 1" I.D. x 2" O.D.
- Self-Lubricating
- Industrial grade nylon

0.013kg/pc
 800
 9600

BB2012

5/8" Commercial Bearing

- Flanged diameter: 1-1/2"
- Standard 5/8" I.D. x 1-3/8" O.D.
- Races case hardened
- Grease packed
- Zinc plated

0.10kg/pc
 200
 10,000

BB2013

1-1/4" Commercial Bearing

- Flanged diameter: 2-5/8"
- Standard 1-1/4" I.D. x 2-1/2" O.D.
- Races case hardened
- Grease packed
- Zinc plated

0.18kg/pc
 2,00
 10,000

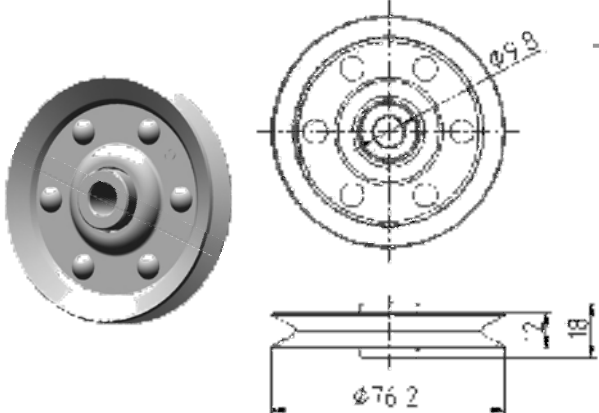



BR 3091

3" Sheave

- Hardened inner bearing raceway
- 9 Steel ball bearing
- 18 gauge steel
- Zinc plated
- Rating: 100 lbs load

 0.13kg/pc

 150

 7,200

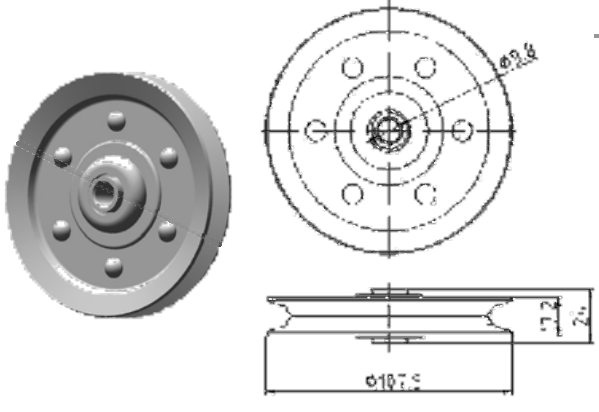



BR 3092

4" Sheave

- Hardened inner bearing raceway
- 9 Steel ball bearing
- 18 gauge steel
- Zinc plated
- Rating: 200 lbs load

 0.34kg/pc

 120

 3,600

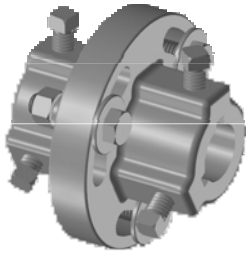
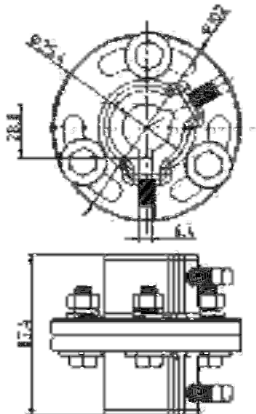

SHAFT COUPLERS





SC 4240

1" Coupler adjustable

- Complete with set screws
- Assembled with 3/8" bolts, nuts, and washers
- FC200-200 lb. min. tensile material
- Rust preventative coating – 72 hrs. salt spray and 480 hrs. humidity test (no rusting)
- Torque rating: 6400 In-lb

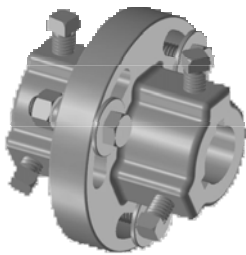
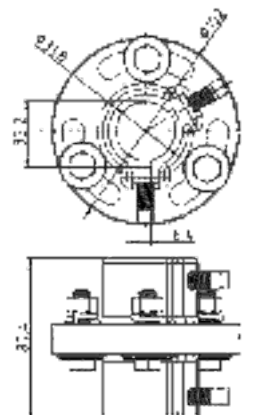

 1.58kg/pc
 12
 420





SC 4245

1-1/4" Coupler adjustable

- Complete with set screws
- Assembled with 3/8" bolts, nuts, and washers
- FC200-200 lb. min. tensile material
- Rust preventative coating – 72 hrs. salt spray and 480 hrs. humidity test (no rusting)
- Torque rating: 6400 In-lb

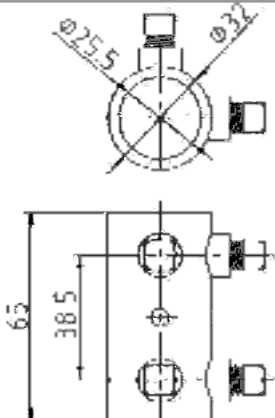

 1.50kg/pc
 12
 420





SC 4246

1" Couple light gauge

- Steel pipe
- Black painting
- For 1" tubular shaft

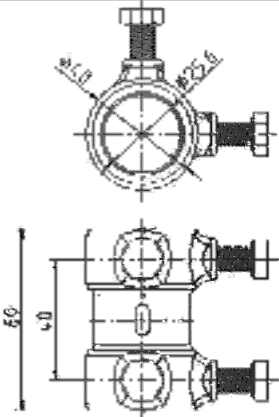

 0.2kg/pc
 100
 1,000

SC 4247

1" Couple Aluminum Casting

- For 1" tubular shaft
- A380 die casting
- Sand blasting finished

 0.16kg/pc
 100
 1,000

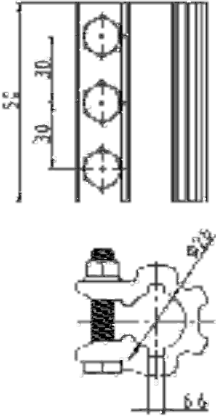

SHAFT COUPLERS





SC 4251

Aluminum Coupler - 90mm

- 2-keyway design
- 3-crew/nuts tighten

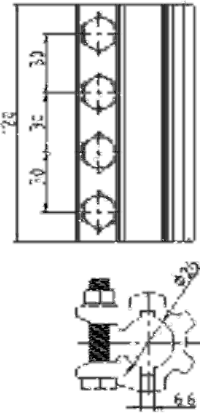

 0.42kg/pc
 40
 3000





SC 4252

Aluminum Coupler - 120mm

- 2-keyway design
- 4-crew/nuts tighten

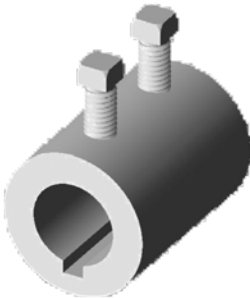
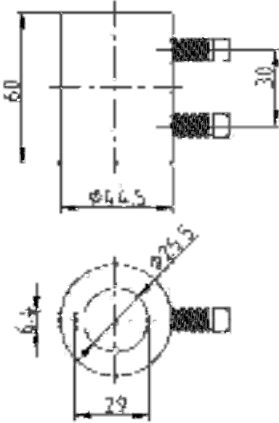

 0.56kg/pc
 40
 2400





SC 4262

Adjustable Coupler - 60mm

- Steel bar machined
- Zinc plated
- With 1/4" keyway

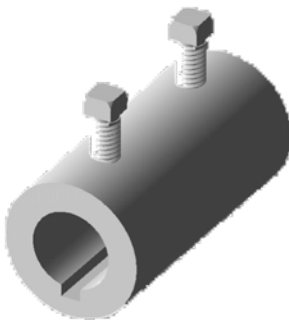
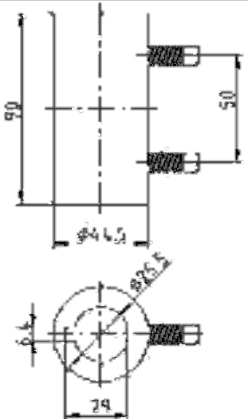

 0.50kg/pc
 40
 1,440





SC 4263

Adjustable Coupler - 90mm

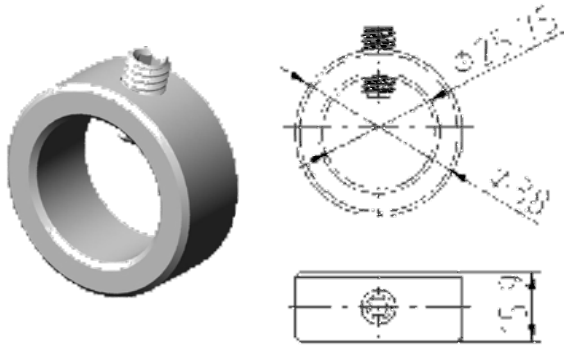

- Steel bar machined
- Zinc plated
- With 1/4" keyway

 0.78kg/pc
 25
 500



BC 0001

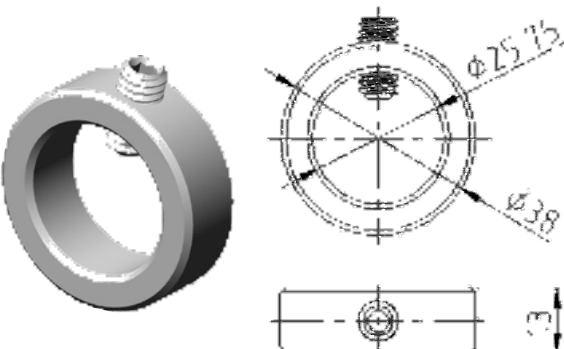

- Zinc plated
- For 1" shaft
- 5/8" width for spacing

 0.073kg/pc
 400
 8,400



BC 0001 Y1

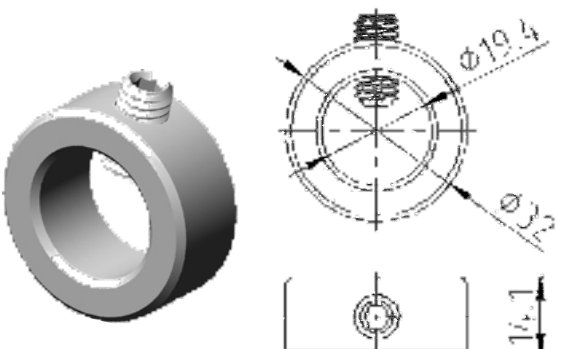

- Zinc plated
- For 1" shaft
- 11/16" width for spacing

 0.06kg/pc
 400
 8,400



BC 0002

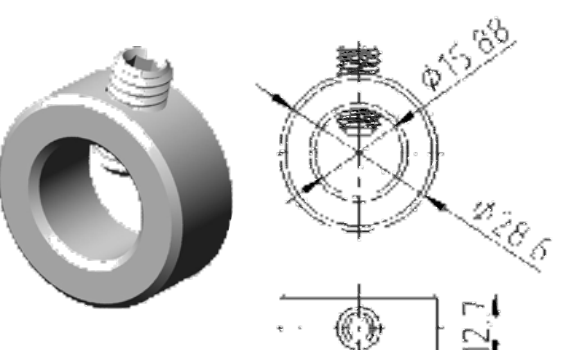

- Zinc plated
- For 3/4" shaft
- 9/16" width for spacing

 0.057kg/pc
 400
 8,400



BC 0003

- Zinc plated
- For 5/8" shaft
- 1/2" width for spacing

 0.032kg/pc
 400
 8,400

SP 4950

SIR900 Chain Hoist (Ratio: 3:1)

- 12T:36T 41B Sprocket
- 1" bore (1-1/4" available)
- 72 links of 41 Roller Chain
- 26' of Hand Chain
- 1 Chain Keeper & 1 Key 1/4"

10kg/pc
 3
 54

SP 5250

SIR880 Chain Hoist (Ratio: 4:1)

- 9T:36T 41B Sprocket
- 1" bore (1-1/4" available)
- Includes:
 - 72 links of 41 Roller Chain
 - 26' of Hand Chain
 - 1 Chain Keeper & 1 Key 1/4"

8.3kg/pc
 3
 54

SP 5260

SDR880 Chain Hoist (Ratio: 1:1)

- Direct Drive for 1" Shaft
- Includes:
 - 26' of Hand Chain
 - 1 Chain Keeper
 - 2 Shaft Collars
 - 1 Key 1/4"

8.0kg/pc
 3
 54

SP 5770

SJR Chain Hoist (Ratio: 4:1)

- 9T:36T 41B Sprocket
- Bearing for 1" Shaft (Bushing available)
- 46 links of 41 Roller Chain
- 26' of Hand Chain
- 1 Chain Keeper
- 2 Shaft Collars
- 1 Key 1/4"

8.3kg/pc
 3
 60

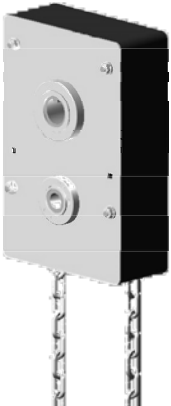

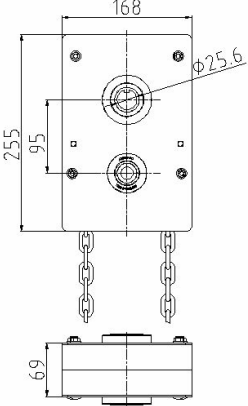



RDR 410

Inside Gear Reduced Hoist (Ratio: 4:1)

- Chain keeper
- 2 Locking collars
- Wall bracket
- For 1" shaft sectional door
- Full steel enclosure
- Cast gear

 9.0kg/pc

 3

 54

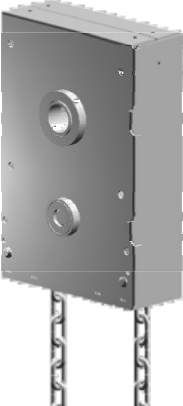

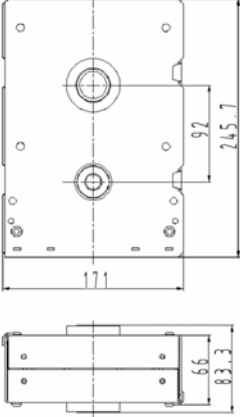



RIR 25025

- Chain keeper
- 2 Locking collars
- Wall bracket
- For 1" shaft sectional door
- Full steel enclosure
- Machined gear

 9kg/pc

 3

 54

SB 0235

Spring Bumper

- Zinc plated
- Direct mounted
- 4" cushion

0.87kg/pc

8

1,280

SB 0485

Spring Bumper

- Zinc plated
- Direct mounted
- 10" cushion
- Adjustable mounting plate available

1.25kg/pc

8

400

HT 0114

1" Tubular Shaft with 1/4" Keyway

- Suitable for rectangular key
- Heavy gauge
- Zinc plated

1.40kg/m

50

N/A

ST 0114

1" Solid Shaft with 1/4" Keyway

- Suitable for square key
- Up to 6 meter per piece
- Plain finish

3.80kg/m

25

350

FS 822

1/4-20x3/4 Tek Screw

- 7/16 Across Face, W/Serration, Point #2
- Zinc plated
- Meet IFI Standard
- Hardened

0.007kg/pc
 3,000
 150,000

FS 823

1/4-20x1" Tek Screw

- 7/16 Across Face, W/Serration, Point #2
- Zinc plated
- Meet IFI Standard
- Hardened

0.008kg/pc
 2,500
 125,000

FS 827

1/4-20x5/8 Ribbed Neck Track Bolt

- Combination head, slot head available
- Zinc plated
- Meet IFI Standard

0.005kg/pc
 4,000
 200,000

FS 841

3/8-16x1 1/2 Machine Screw

- Full thread
- Zinc plated
- Meet IFI Standard

0.023kg/pc
 800
 40,000

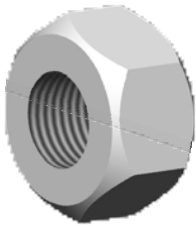
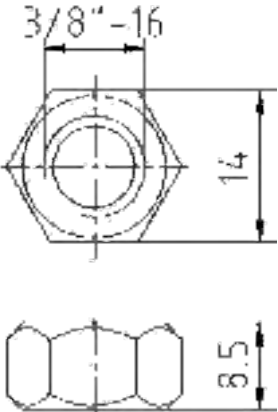



FS 843

3/8-16 Hex Nut

- 7/16 Across Face, W/Serration, Point #2
- Zinc plated
- Meet IFI Standard

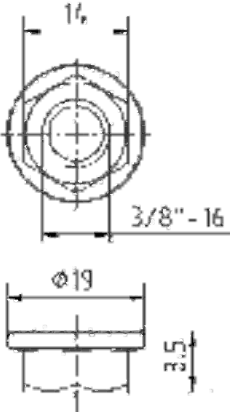
0.006kg/pc
 2,500
 125,000





FS 8244

3/8-16 Whiz Flange Nut Zinc

- Zinc plated
- Meet IFI Standard
- With Anti-tighten serration

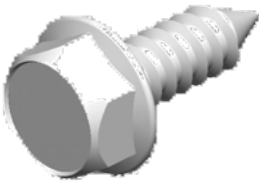
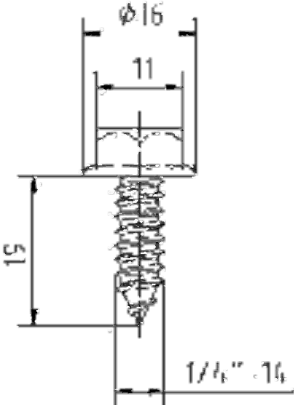
0.008kg/pc
 2,500
 125,000





FS 8212

1/4x3/4\" Sheet Metal Screw

- Zinc plated
- Meet IFI Standard
- Hardened available
- 7/16\" across face

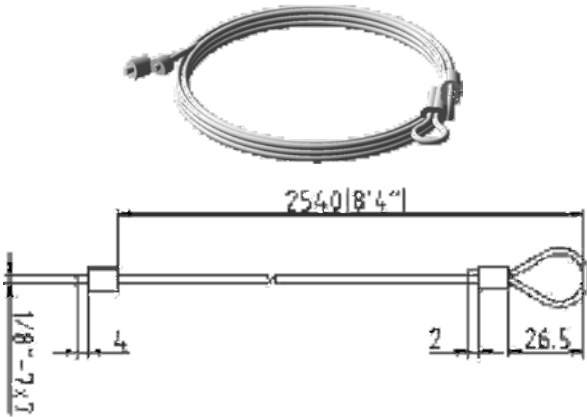
0.007kg/pc
 2,500
 125,000



CT 0847

Cable

- Customized length
- Extension
- Torsion
- Safety
- 1/8\" x 7 x 7
- 1/8\" x 7 x 19

SB 0211

Chain Keeper

- 2 bolt holes
- Padlock hole
- Zinc plated

0.01kg/pc
 100
 5,000

SS 3000

Spring Support

- Cut-to-length
- 4"O.D. x 1-1/2" I.D.
- Rigid plastic

0.05kg/pc
 N/A
 N/A

SS 3600

Spring Support

- Cut-to-length
- 4"O.D. x 1-1/2" I.D.
- Rigid plastic

0.06kg/pc
 N/A
 N/A

RW 0001

Weight Bar

- 1kg per bar
- Black painting

1.0kg/pc
 20
 1000

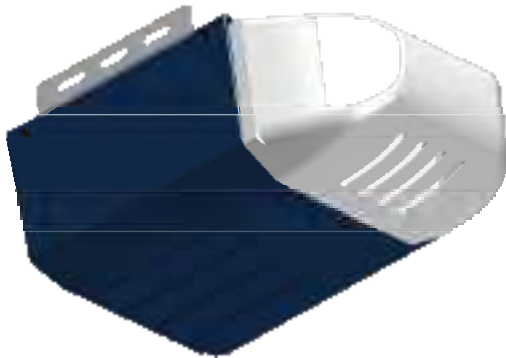

Sectional Garage Door Openers

- Equipped with powerful AC or smooth DC motor
- For residential sectional door up to height of 10'
- Dual 100W lighting system available
- Complies with UL325

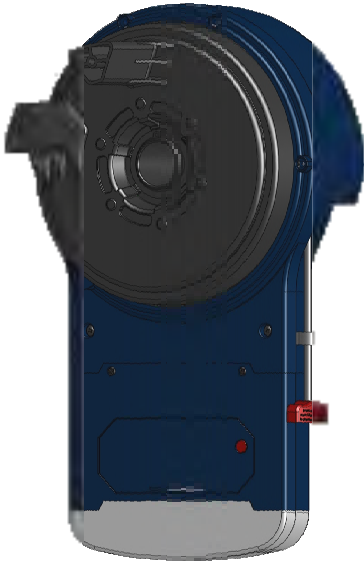

Roller Door Openers

- Equipped with powerful DC motor
- For roller door size up to 16.5m²
- LED-array courtesy light
- Optional Battery-Backup

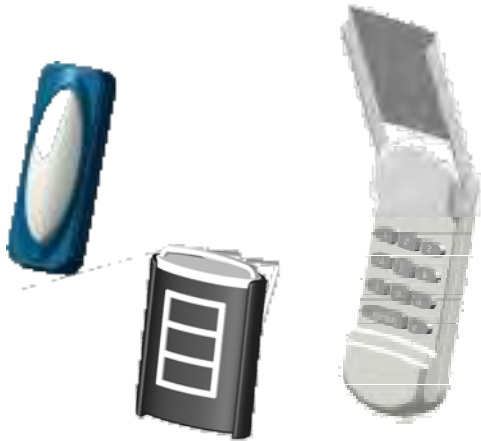

Accessories

Accessories including remote controls and Wireless keyless Entry Keypad provide ease-of-access to your door.

SECTIONAL DOOR OPERATOR - ACS 1/2 HP

Electrical Rating

Input	AC 120V 60Hz or 240V 50Hz
Current	4.5A
Power	375W
Standby power	2W

Motor

Type	120V Single phase 1/2HP
------	-------------------------

Recommended Lifting Forces

Lifting force-spec.	750N/165lbf
Lifting force-rec.	150N/33lbf

Door Travel

Door travel limits	3m/10 ft
Trolley travel speed	190mm/s 7.5in/s

Courtesy Light

Light bulb	1 x 100W
Lighting duration	4.5 minutes

Radio Controls

Frequency	303 or 433.92 MHz
Operation range	30m/100ft (open-field)
Coding type	Fixed-code
Battery	12V (A23 Alkaline) x 1

Miscellaneous

Carton Dimension	466x290x198mm/18.3"x11.4"x7.8"
Carton Weight	9.5kg/21lbs
Rail / Drive	T or C-rail/ chain or belt

Safety and Features

Down safety reversal
Up safety stop
Infra-red Photo-eyes
Emergency Quick Release

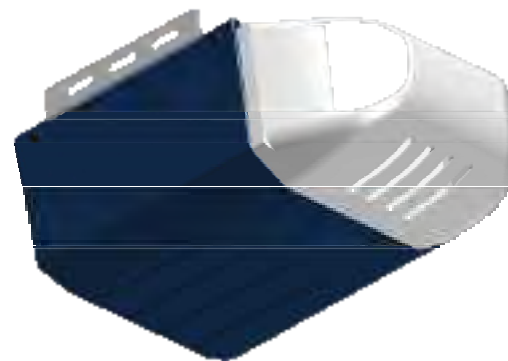

Interfaces

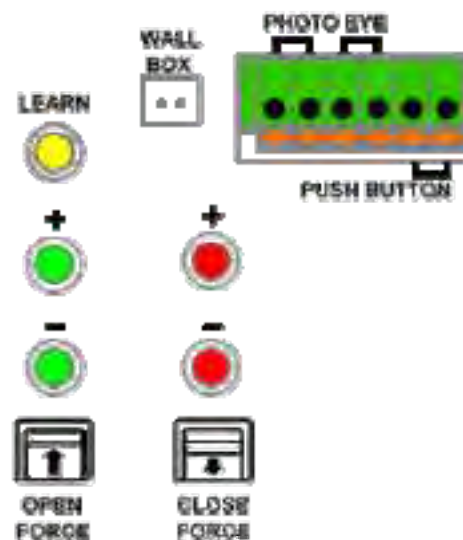

Dimensions

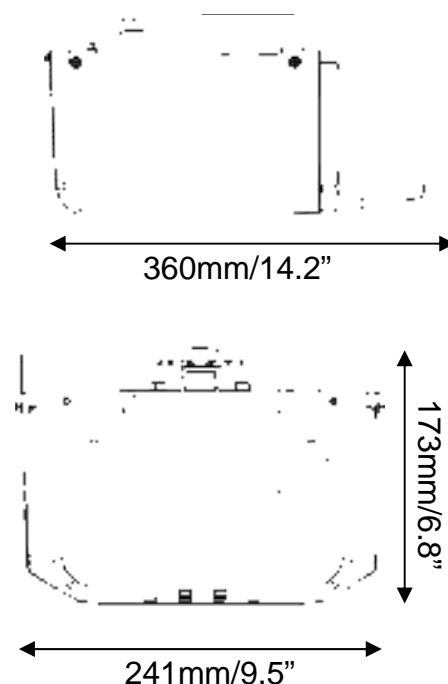

SECTIONAL DOOR OPERATOR — DCS 1/2HPE

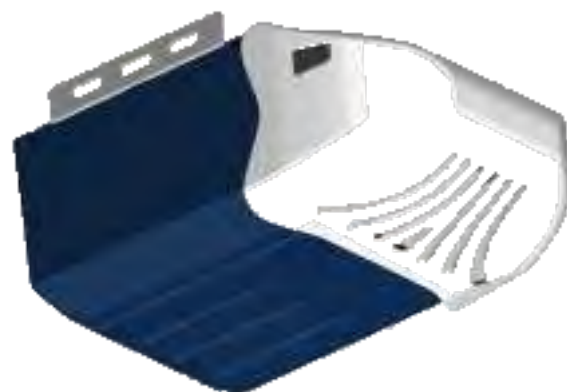

Electrical Rating

Input	AC 120V 60Hz or 240V 50Hz
Current	<1A
Power	100W
Standby power	2W

Motor

Type	DC 24V Brush
------	--------------

Lifting Forces

Lifting force-spec.	750N/165lbf
Lifting force-rec.	150N/33lbf

Door Travel

Door travel limits	3m/10ft
Trolley travel speed	150mm/s 5.8in/s

Courtesy Light

Light bulb	1 x 100W
Lighting duration	4.5 minutes

Radio Controls

Frequency	303MHz or 433.92MHz
Operation range	30m/100ft (open-field)
Coding type	Fixed-code
Battery	12V (A23 Alkaline) x 1

Miscellaneous

Carton Dimension	466x290x198mm/18.3"x11.4"x7.8"
Carton Weight	9.0kg/20lbs
Rail / Drive	T or C-rail/ chain or belt

Safety and Features

Down safety reversal
Up safety stop
Infra-red Photo-eyes
Emergency Quick Release
Soft start & stop
Auto-learn force

Interfaces

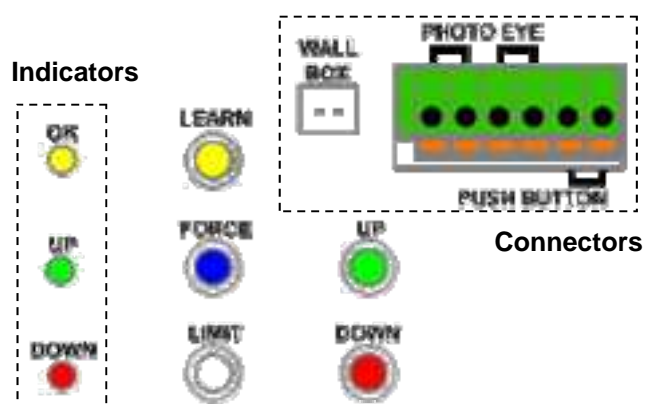

Controls

Dimensions

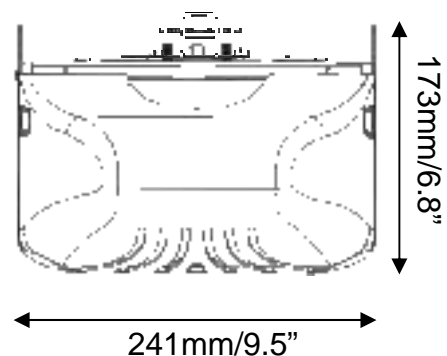
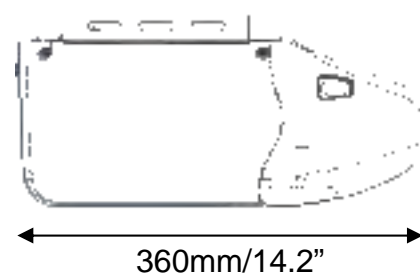

SECTIONAL DOOR OPERATOR — DCS 3/4HPE

Electrical Rating

Input	AC 120V 60Hz or 240V 50Hz
Current	1A
Power	120W
Standby power	2W

Motor

Type	DC 24V Brush
------	--------------

Lifting Forces

Lifting force-spec.	850N/185lbf
Lifting force-rec.	150N/33lbf

Door Travel

Door travel limits	3m/10ft
Trolley travel speed	150mm/s 5.8in/s

Courtesy Light

Light bulb	2 x 100W (200W)
Lighting duration	4.5 minutes

Remote Control

Frequency	303MHz or 433.92MHz
Operation range	30m/100ft (open-field)
Coding type	Fixed-code
Battery	12V (A23 Alkaline) x 1

Miscellaneous

Carton Dimension	628x 290x198mm/25"x11.4"x7.8"
Carton Weight	9.1kg / 20lbs
Rail / Drive	T or C-rail/ chain or belt

Safety and Features

Down safety reversal
Up safety stop
Infra-red Photo-eyes
Emergency Quick Release
Soft start & stop
Auto-learn force



Interfaces

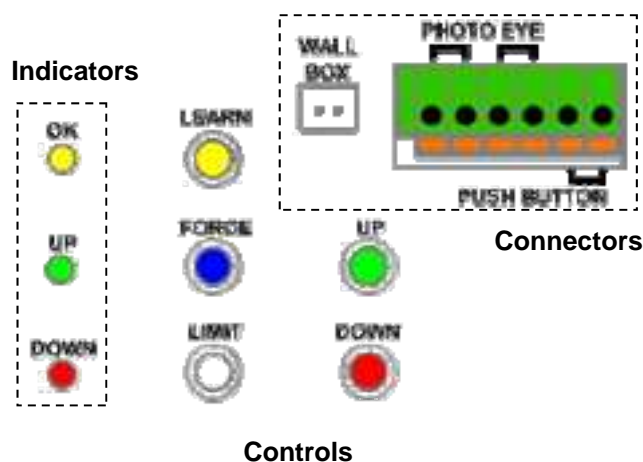

Indicators

Connectors

Controls

Dimensions

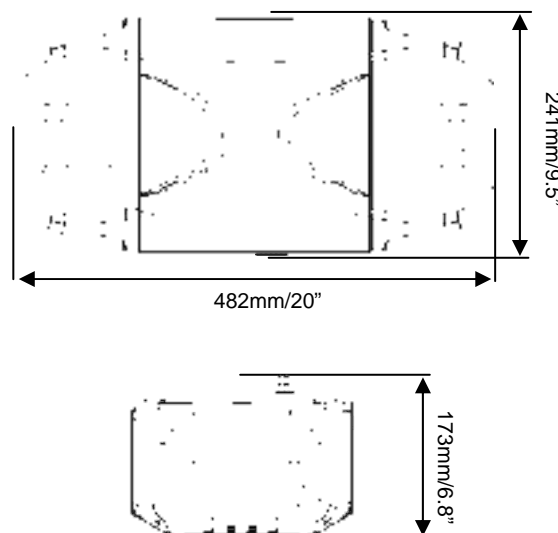

SECTIONAL DOOR OPERATOR — DCS1

Electrical Rating

Input	AC 120V 60Hz or 240V 50Hz
Current	1A
Power	120W
Standby power	2W

Motor

Type	DC 24V Brush
------	--------------

Lifting Forces

Lifting force-spec.	850N/185lbf
Lifting force-rec.	150N/33lbf

Door Travel

Door travel limits	3m/10ft
Trolley travel speed	150mm/s 5.8in/s

Courtesy Light

Light bulb	1 x 60W
Lighting duration	4.5 minutes

Remote Control

Frequency	303MHz or 433.92MHz
Operation range	30m/100ft (open-field)
Coding type	Fixed-code
Battery	12V (A23 Alkaline) x 1

Miscellaneous

Carton Dimension	495x 295x192mm/19.5"x11."x7.6"
Carton Weight	9.1kg / 20lbs
Rail / Drive	C-rail/ chain or belt

Safety and Features

Down safety reversal
Up safety stop
Infra-red Photo-eyes
Emergency Quick Release
Soft start & stop
Auto-learn force

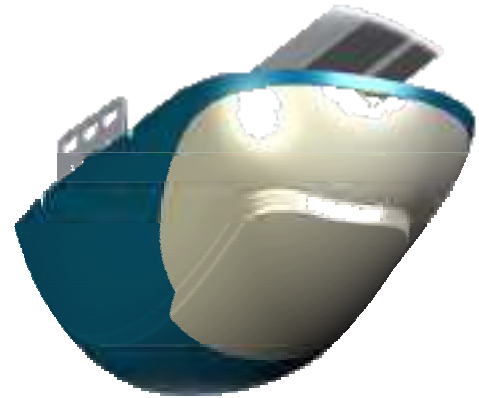

Interfaces

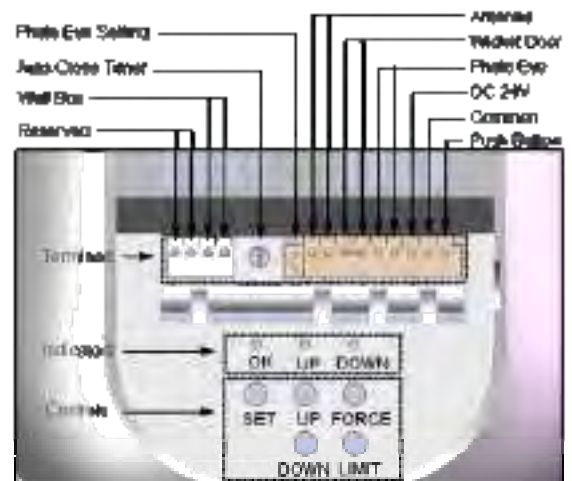

Dimensions

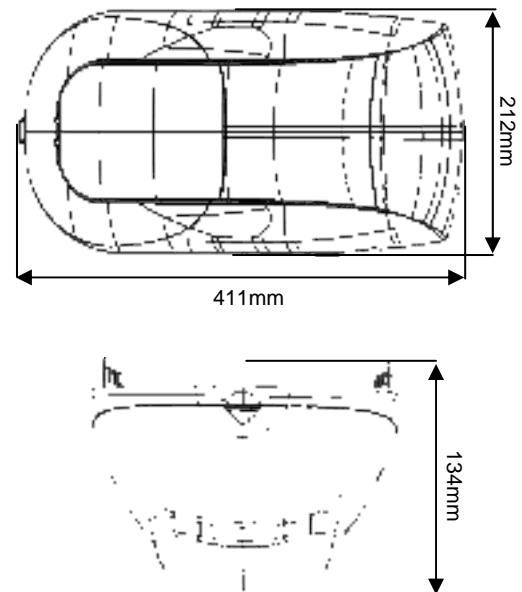

ROLLER DOOR OPERATOR — DCR2

Electrical Rating

Input	AC 120V 60Hz or 240V 50Hz
Max. Current	<1A
Power	100W
Standby Power	2W
Fuse	5A slow-blow replaceable

Motor

Type	DC 24V brushed
Max. Capacity	1000N

Recommended Lifting Forces

Max. Lifting Force	60kg
Rated Lifting Force	15kg

Door Type

Max. Door Size	16.5m ²
Max. Door Weight	45kg Spring-balanced
Door Travel Limits	4.5 turns of door drum

Courtesy Light

Light Source	Ultra Bright LEDs (6000K)
Lighting Time	4.5 minutes

Radio

Frequency	303/433.92 MHz
Operation Range	20ft (open field)
Coding Type	Fixed-code
Battery	12V (A23 Alkaline) x 1

Miscellaneous

Operating Temperature	-20°C ~ +50°C
Carton Dimension	453x 264x 203mm/17.8"x10.4"x8"
Weight	8kg approx.

Safety and Features

Down safety reversal
Up safety stop
Infra-red Photo-eyes
Emergency Quick Release
Soft start & stop
Auto-learn force
Battery-Backup module for uninterrupted access (optional) 24 hours standby normal operation

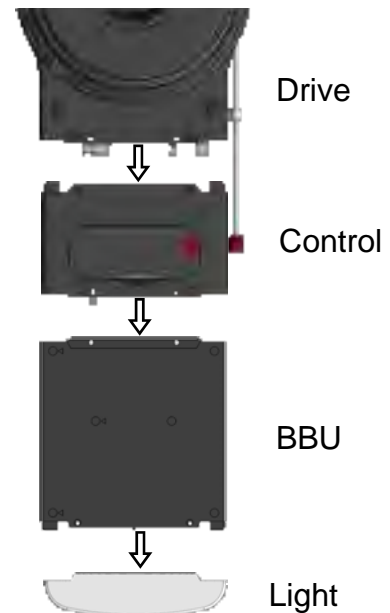

BBU Direct-

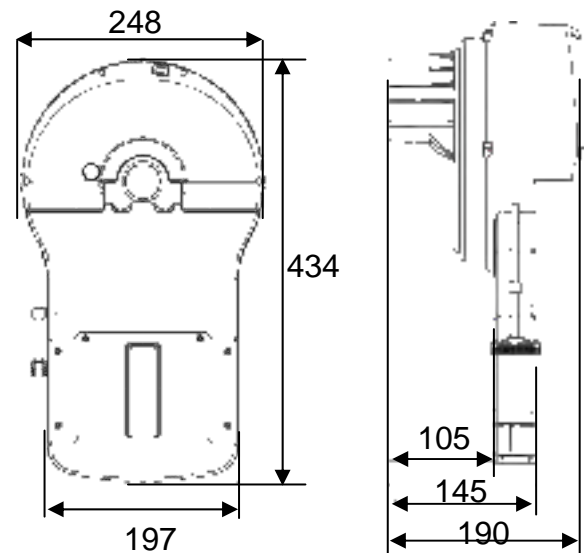

OPENER ACCESSORIES



Standard Push Button (STDPB)



Wireless Keyless Entry Keypad (GWOWLESKEY)



Wireless Keyless Entry Keypad (GDOWLESKEY)

- Illuminated Keypad
- Weather-proof



Premium Mini 3-Button Remote Control (GDO3BMINI)

- 3 Button
- Zinc metallic finish



Premium 3-Button Remote Control (GDOP3B)

- Ultra slim profile
- LED Indicator



Standard 2-Button Remote Control (GDOR2B)



Standard 3-Button Remote Control (GDO3BSTD)



Photo Eye Safety System



Premium Door Control Console (PWLLSTN)



Deluxe Door Control Console (DLXWLLSTN)

- Door Button
- Light Switch
- Vacation Lock



External Receiver (EXTRCVR)

- Compatible with all brands
- Controls up to 2 openers

COMPANY PROFILE



Office Building



Manufacturing Plant

Our Mission

Guardian strives to exceed the expectations of our customers through our comprehensive service, innovative designs, and uncompromising demand for quality.

The goal is being achieved with a 216,000 sq.ft manufacturing plant in Shanghai, equipped with diversified manufacturing facilities for door hardware and door openers.

We extend our resources to our customers, from technical consultation, conducting feasibility studies, to sourcing. We will tailor our services for you.

Guardian has a strong belief in long term relationships, we demand the utmost ethical standards in all our relationships. to provide a hassle-free "one stop shop" to our loyal customers for all garage door related products.



MANUFACTURING FACILITIES



Molding



Stamping



Plastic Injection



Weather Seal Assembly



Opener Circuit Board Assembly

- PCB soldering
- PCB assembly
- PCB In-circuit Tests
- Simulation & Verification



Opener Production Lines

- OBM / ODM / OEM Opener Products
- Complete functional and safety testing
- Annual production capability of 300,000 units

To purchase hardware in this catalog please contact:

Guardian Access & Door Hardware

California Location 9732 Albutis Ave. Santa Fe Springs, CA 90670

TEL : +1 (562) 948-1816

FAX: +1 (562) 948-1672

email : info@adhguardian.com

Guardian Shanghai Corp.

368, Min Shen Rd, SongJiang, Shanghai, China (201612)

TEL : +86 (21) 57684828

FAX : +86 (21) 57685151

email : main@adhguardian.com



www.adhguardianusa.com