

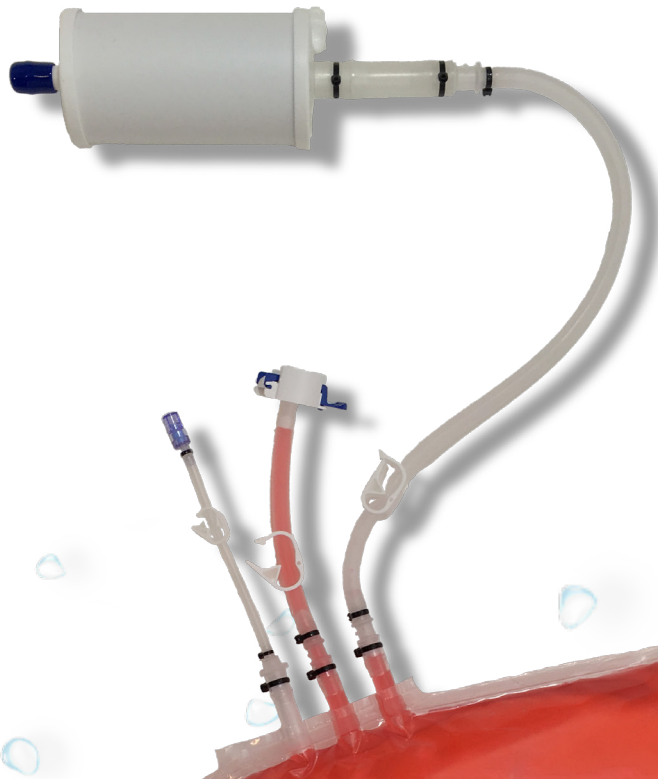

# **FLEXBIOSYS**

*Flexible Design, Accelerating Your Results*



**SINGLE-USE CONTAINERS, ASSEMBLIES, AND SYSTEMS FOR BIOPROCESSING**

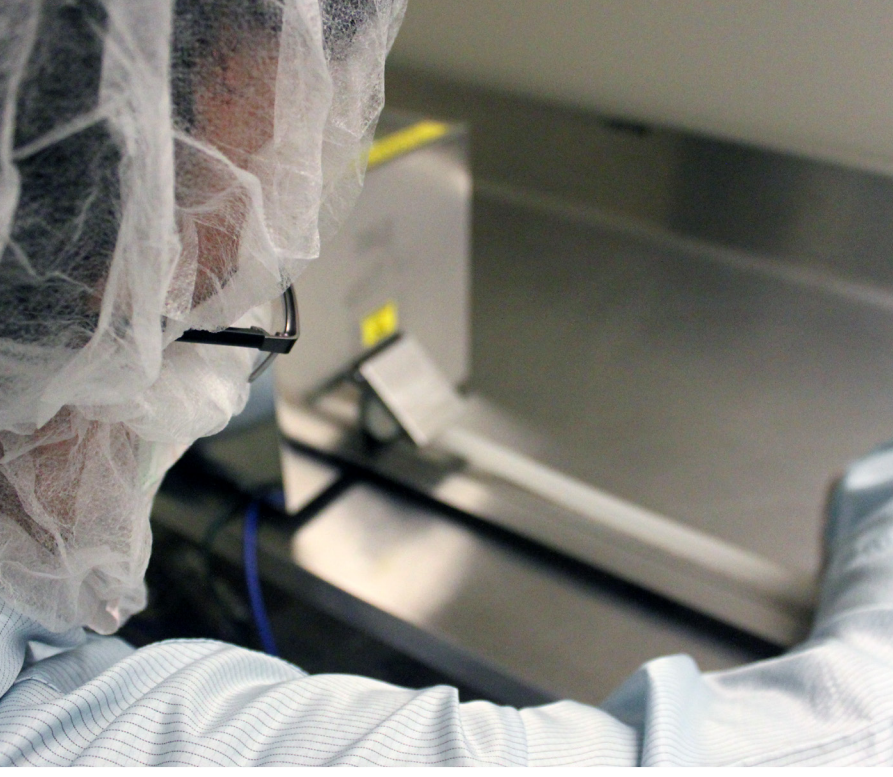



# WELCOME TO FLEXBIOSYS!

Thank you for your interest in FlexBiosys. Our goal is to provide you with outstanding design services and manufacture single-use biopharmaceutical products that surpass your expectations. We were founded on the idea of offering total custom solutions for single-use bioprocessing needs. Whether you are a current customer or meeting us for the first time, you can be assured we will meet those goals for you!

## WHAT WE DO

FlexBiosys offers expert design and custom manufacturing of single-use bioprocessing products. We offer a comprehensive range of products that include bioprocessing bags, bottles, and tubing assemblies. All manufacturing is done in our state-of-the-art ISO Class 7 certified cleanroom, located in Lebanon, NJ. We offer completely custom tailored solutions for your bioprocessing needs, and have a design team with over 35 years of experience to help you make your vision a reality.

## QUALITY MANAGEMENT SYSTEM

At FlexBiosys, quality is built into our process. We operate a quality system that is ISO 9001:2015 certified and securely maintain full traceability of our manufactured goods. While we are ISO 9001:2015 certified, our quality system also maintains many aspects of ISO 13485:2016 and cGMP standards. Our products are manufactured in an ISO Class 7 certified cleanroom, to ensure an absolute level of control. At FlexBiosys we strive to pass the most stringent evaluations – our customer's audits. Our systems have satisfied the most demanding requirements of medical device manufacturers and we welcome you to conduct your own on-site supplier audit.



**Intertek**

# CONTENTS

---

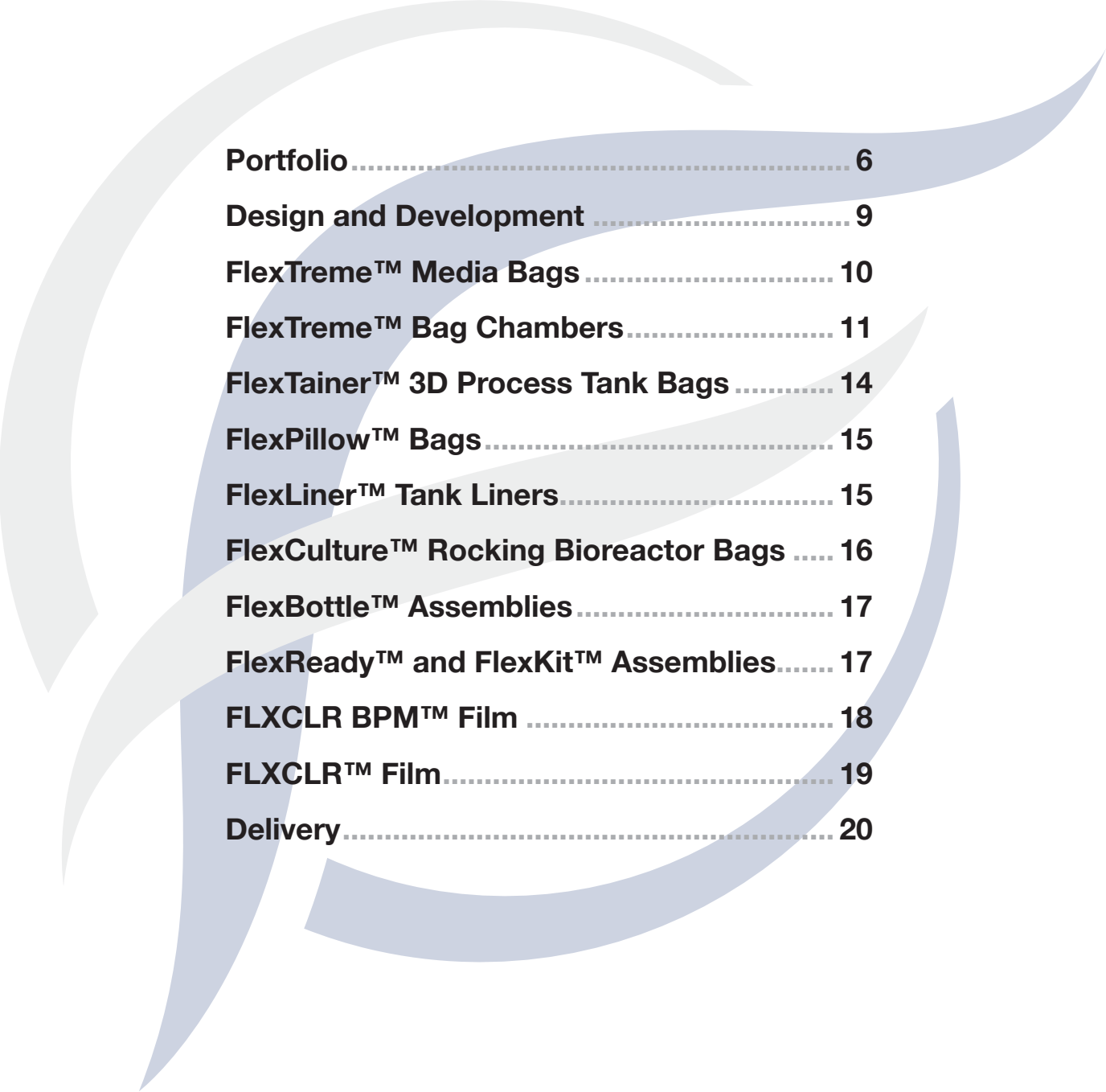

<b>Portfolio</b> .....	<b>6</b>
<b>Design and Development</b> .....	<b>9</b>
<b>FlexTreme™ Media Bags</b> .....	<b>10</b>
<b>FlexTreme™ Bag Chambers</b> .....	<b>11</b>
<b>FlexTainer™ 3D Process Tank Bags</b> .....	<b>14</b>
<b>FlexPillow™ Bags</b> .....	<b>15</b>
<b>FlexLiner™ Tank Liners</b> .....	<b>15</b>
<b>FlexCulture™ Rocking Bioreactor Bags</b> .....	<b>16</b>
<b>FlexBottle™ Assemblies</b> .....	<b>17</b>
<b>FlexReady™ and FlexKit™ Assemblies</b> .....	<b>17</b>
<b>FLXCLR BPM™ Film</b> .....	<b>18</b>
<b>FLXCLR™ Film</b> .....	<b>19</b>
<b>Delivery</b> .....	<b>20</b>

---

# PORTFOLIO

---

**FlexTreme™ 2D Media Bags**

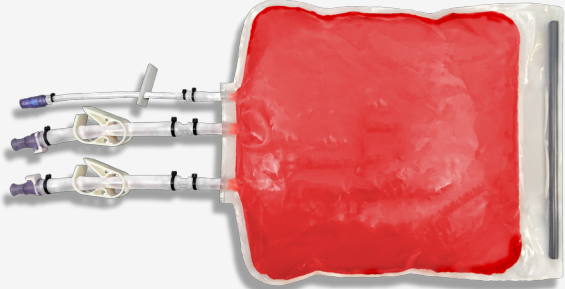

**FlexPillow™ Bags**

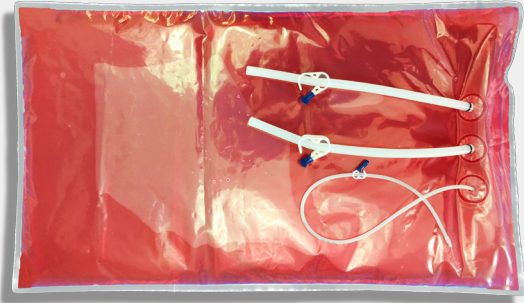

**FlexCulture™ Rocking Bioreactor Bags**

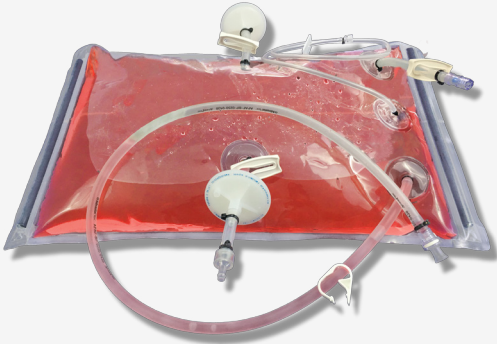

**FlexTainer™ 3D Process Tank Bags**



**FlexBottle™ Assemblies**



**FlexLiner™ Tank Liners**



**FlexReady™ and FlexKit™  
Tubing Assemblies**



SEE DETAIL, SHEET 2

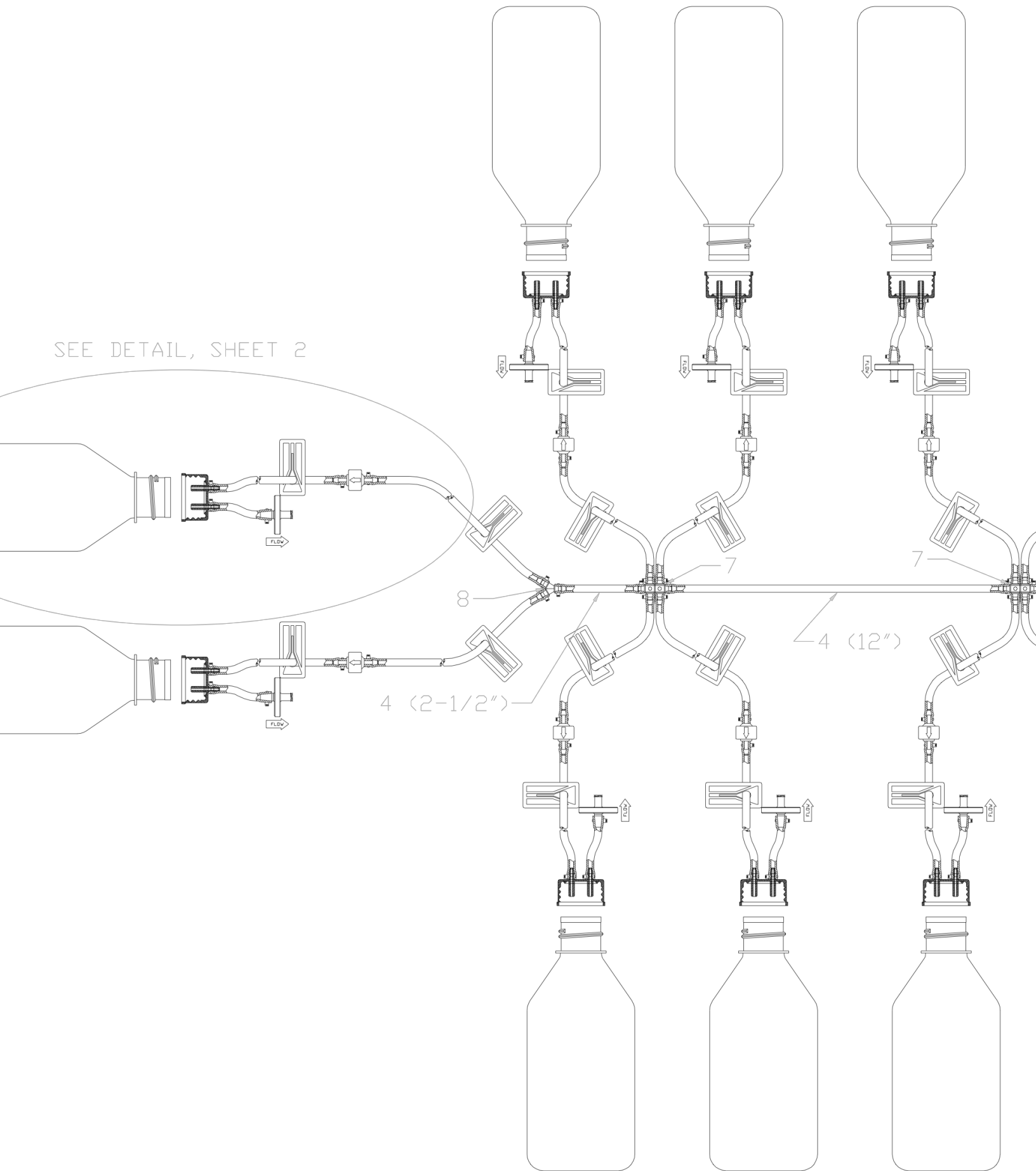



# DESIGN AND DEVELOPMENT

---

## FAST, FLEXIBLE DESIGN

Our engineers have over 35 years of industry specific experience behind them. Single-use solutions for bioprocessing is all they know. At FlexBiosys, we provide totally customized solutions for your specific needs. We have an extensive product line to cover everything you can imagine and with over a thousand different components in our warehouse, and knowledge of even more, we will be able to design the single-use product that is right for you.

## QUICK QUOTES

Within days of designing your custom single-use solution, you will have a drawing on your desk. Our experience enables us to streamline our entire design and development process which means you get what you need, when you need it.

## OVER 500 CUSTOM SOLUTIONS

We are dedicated to finding the solution that is right for you. Our customers know that, and that is why we have such a massive portfolio of products. Whether you are a current customer or new to FlexBiosys, we will continue to provide fast, flexible design to meet your single-use bioprocessing needs.

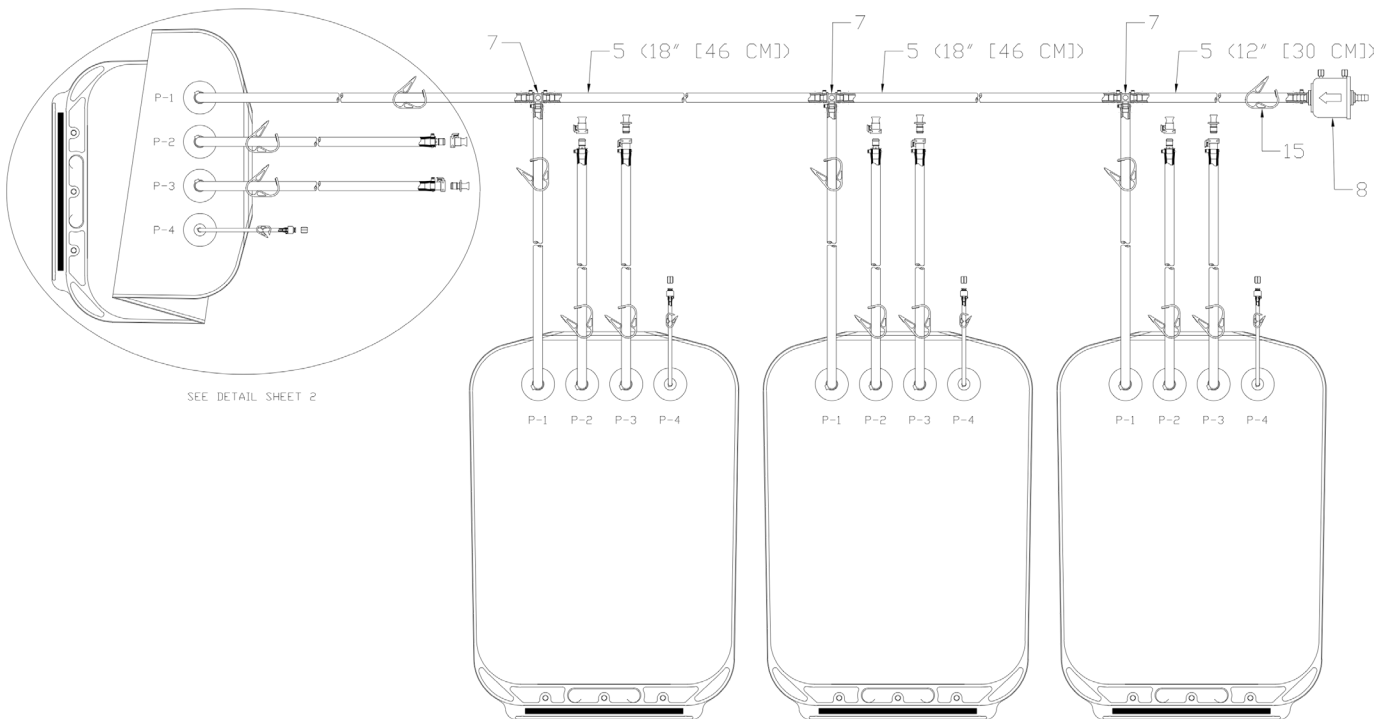

# FLEXTREME™ MEDIA BAGS

---

## TOTALLY CUSTOM DESIGNED TO FIT YOUR NEEDS

FlexTreme™ bags are single-use systems engineered for biopharmaceutical applications. Single-use bags minimize the risk of contamination, reduce cleaning costs, and shorten process turnaround time. FlexTreme™ bags are manufactured in an ISO Class 7 Certified Cleanroom and are engineered to optimize the self draining process. This allows for seamless self draining of our bags, eliminating the need for dip tubes and putting an end to other common problems such as air entrapment and foaming.

Our bioprocessing bags are manufactured in Lebanon, NJ and can be custom tailored to fit your needs. The bags shown on the next two pages show the maximum number of ports, and the inner diameter of the ports. The number of ports can be reduced to better fit your application and the inner diameter can be reduced or increased to any dimension via reduction couplers. The bag can then be manufactured with tubing, clamps, filters, and other components of your choice. FlexTreme™ bioprocessing bags are available with end ports or with flange ports.

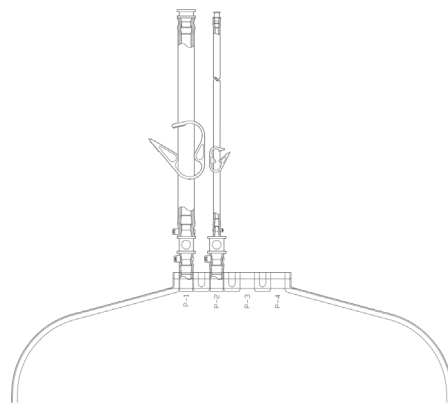

## PROVEN RELIABILITY

FlexTreme™ bags are made with FLEXCLR BPM™ film with an inert mLLDPE product contact layer and EVOH gas barrier to ensure complete compatibility with your biological processing. FLEXCLR BPM™ Film undergoes the most rigorous tests currently available and meets USP Class VI Plastics Testing. FLEXCLR BPM™ Film is Free of Animal Derived Components. BPOG Protocol Extractables Data is also available for this film.

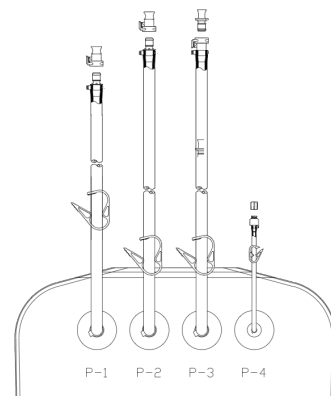

# FLEXTREME™ BAG CHAMBERS

---

50ml

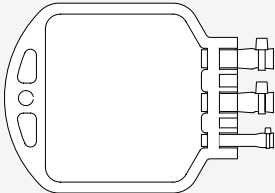

Port 1/4" ID  
Port 1/4" ID  
Port 1/8" ID

Single Layer

150ml

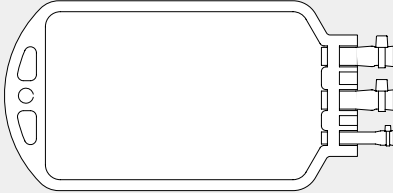

Port 1/4" ID  
Port 1/4" ID  
Port 1/8" ID

Single Layer

250ml

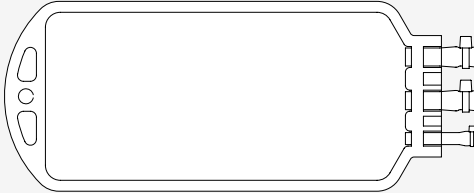

Port 1/4" ID  
Port 1/4" ID  
Port 1/8" ID

Single Layer

500ml

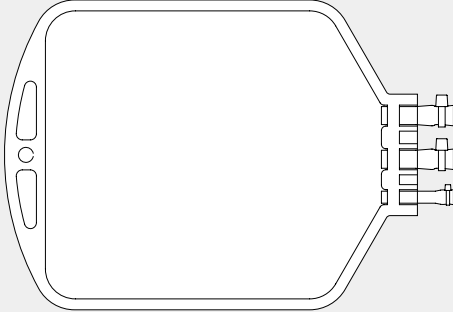

Port 1/4" ID  
Port 1/4" ID  
Port 1/8" ID

Single Layer

**1L**

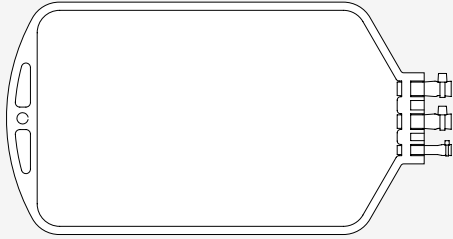

**Port 1/4" ID**  
**Port 1/4" ID**  
**Port 1/8" ID**

**Single Layer**

**2L**

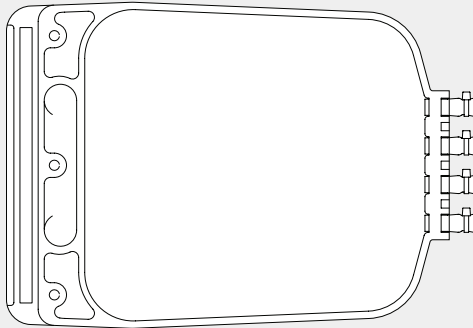

**Port 3/8" ID**  
**Port 3/8" ID**  
**Port 3/8" ID**  
**Port 3/8" ID**

**Dual Layer**

**3L**

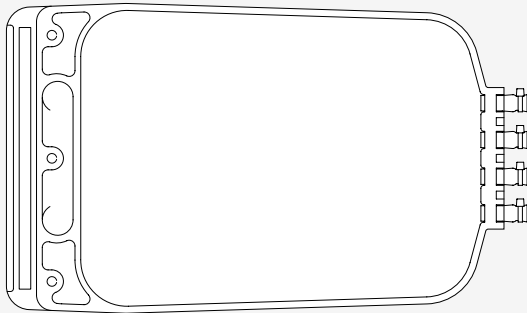

**Port 3/8" ID**  
**Port 3/8" ID**  
**Port 3/8" ID**  
**Port 3/8" ID**

**Dual Layer**

**5L**

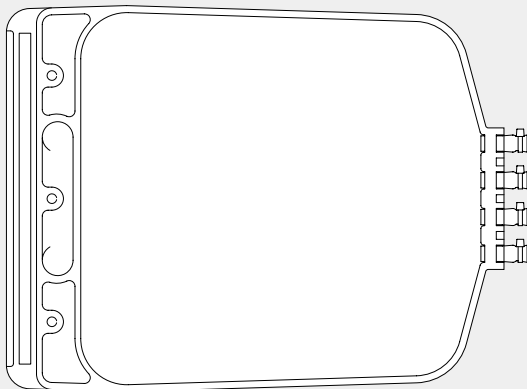

**Port 3/8" ID**  
**Port 3/8" ID**  
**Port 3/8" ID**  
**Port 3/8" ID**

**Dual Layer**

**10L**

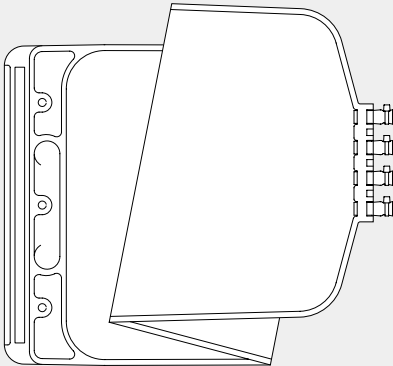

**Port 3/8" ID**  
**Port 3/8" ID**  
**Port 3/8" ID**  
**Port 3/8" ID**

**Dual Layer**

**20L**

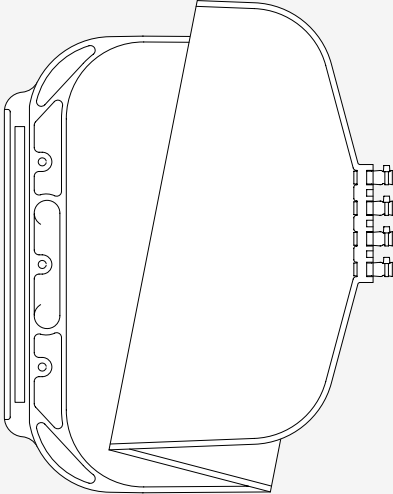

**Port 3/8" ID**  
**Port 3/8" ID**  
**Port 3/8" ID**  
**Port 3/8" ID**

**Dual Layer**

**50L**

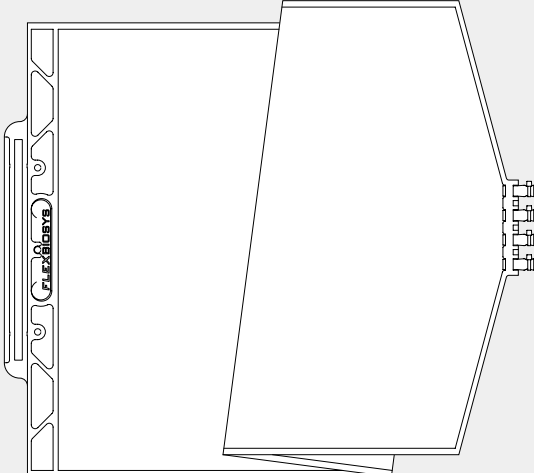

**Port 3/8" ID**  
**Port 3/8" ID**  
**Port 3/8" ID**  
**Port 3/8" ID**

**Dual Layer**

# FLEXTAINER™ 3D PROCESS TANK BAGS

---



## SAME PROVEN RELIABILITY, BUT IN 3D

FlexTainer™ 3D Process Tank Bags are manufactured from FLEXCLR BPM™ film (the same film as FlexTreme™ Media Bags), but are custom tailored to the precise dimensions you need to fit your bioprocess tank. FlexTainer™ 3D Process Tank Bags can be made to fit any tank, both rectangular and cylindrical, and flange ports can be placed in any location to optimize your process. FlexTainer™ Bags can be manufactured with tubing, clamps, filters, and other components of your choice, and are available with anchored or free dip tubes.

Available Sizes: 10L – 500L



# FLEXPILLOW™ BAGS

---

FlexPillow™ Bags are made from FXLCR BPM™ Film and are custom manufactured to fit your needs. FlexPillow™ Bags can be designed to the dimensions you require and with tubing, clamps, filters, and other components of your choice.

Available Sizes: 50L – 500L



# FLEXLINER™ TANK LINERS

---

FlexLiner™ Tank Liners are made from FXLCR BPM™ Film and, as always, are custom manufactured to fit your needs. FlexLiner™ Tank Liners Bags can be designed to the dimensions you require and with tubing, clamps, filters, and other components of your choice. FlexLiner™ Tank Liners can be made to fit any tank, both rectangular and cylindrical, and flange ports can be placed in any location to optimize your process.

Available Sizes: 20L – 1000L



# FLEXCULTURE™ ROCKING BIOREACTOR BAGS

---

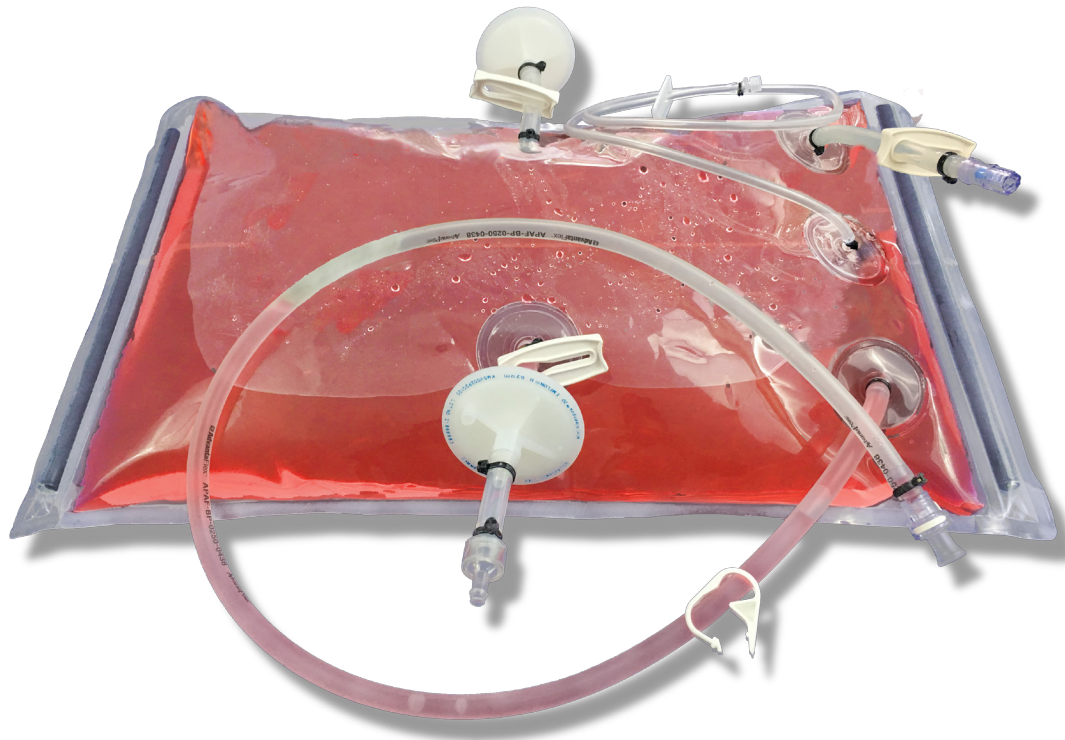

## DESIGNED TO FIT YOUR SYSTEM

FlexCulture™ Rocking Bioreactor Bags are single-use cell culture systems designed to fit your rocking motion bioreactor system. FlexCulture™ bags are manufactured to your custom configuration.

## CELL CULTURE OPTIMIZED FILM, SAME PROVEN RELIABILITY

FlexCulture™ Bags are manufactured utilizing FLEXCLR™ Film with an inert ULDPE product contact layer for optimal cell growth and an EVOH gas layer supporting control of critical gasses. FLEXCLR™ film maximizes flexural fatigue strength while having broad cell culture compatibility and is extensively used in the biopharmaceutical industry. FLEXCLR™ film has been tested and documented for leachable and extractables by a leading contract laboratory. FLEXCLR™ Film meets USP Class VI Plastics Testing and is free of animal derived components.



# FLEXBOTTLE™ ASSEMBLIES

---

Custom bottle assemblies are available with a fully characterized molded stopper assembly for critical applications or a cap assembly for a totally customized solution. Molded stopper assemblies are available in TPE or Silicone. Both assemblies allow for 2 to 3 closure ports and are available with or without dip tubes.

Custom molded or cap assemblies, without a bottle, are also available.



# FLEXREADY™ AND FLEXKIT™ TUBING ASSEMBLIES

---

## GAMMA IRRADIATED OR NON-IRRADIATED TUBING ASSEMBLIES

Bioreactor Tubing Sets are assembled using your preferred materials. Transfer tubes are ready for weld on application or fitted with aseptic connectors. Tubing assemblies are available gamma irradiated at 25-40kGy (FlexReady™) or as non-irradiated assemblies (FlexKit™).



# FLXCLR BPM™ FILM

The FLEXCLR-BPM™ process container film system is a 12 mil, durable, medical grade, and dual film system. The outer film is a 7 mil multilayer film designed specifically for applications requiring high puncture and abrasion resistance. The outer surface of the film is composed of Nylon which provides strength and dimensional stability. An inner layer of EVOH acts as a gas barrier and the Metallocene LLDPE contact layer provides an inert contact material for most biological processing fluids. The FLEXCLR BPM™ film is free of animal derived components.



## PHYSICAL PROPERTIES

Property	Test Method	Values (Outer Film – Typical)	Values (Inner Film – Typical)
Film Thickness		0.007in (7 mil)	0.005in (5 mil)
Haze	ASTM D1003	34%	24%
Tensile Strength MD, TD	ASTM D882A	5400 psi, 5500 psi	5500 psi, 5300 psi
Elongation MD, TD	ASTM D882A	600%, 625%	850%, 865%
Tear Strength MD, TD	ASTM D1922	1500 grams, 1700 grams	1500 grams, 2200 grams
Dart Impact	ASTM D1709	> 1600 grams	N/A
Oxygen (O2) Transmission	ASTM D3985	0.04 cc/100 in2/24hrs	N/A

## BIOCOMPATIBILITY DATA

Property	Test Method	Values (Post irradiation @ min. 25kGy)
Intracutaneous Toxicity	USP Class VI <88>	Passed
Acute Systemic Toxicity	USP Class VI <88>	Passed
Muscle Implantation	USP Class VI <88>	Passed
Cytotoxicity	USP 26 <87>	Passed
Bacterial Endotoxin	USP 26 <85>	Passed
Heavy Metals	USP 26 <661>	Passed
Buffering Capacity	USP 26 <661>	Passed
Non Volatile Residue	USP 26 <661>	Passed

# FLEXCLR™ FILM

FLEXCLR™ bioreactor film is a durable, medical grade multilayer film designed specifically for biopharmaceutical cell culture applications. The LDPE outer layer provides a strong, flexible, puncture resistant protective barrier. Proven EVOH (polyethylene vinyl alcohol copolymers) is used as a gas barrier layer providing for control of cell culture gas concentrations. The inert ULDPE inner product contact layer provides broad compatibility in cell culture. FLEXCLR™ film is strong, clear, exceptionally flexible, and well characterized for leachables and extractables. The FLEXCLR™ film is free of animal derived components.

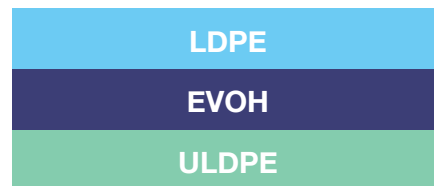

## PHYSICAL PROPERTIES

Property	Test Method	Values (Post gamma irradiation @ min. 25kGy)
Film Thickness		0.0128in / 0.325mm
Clarity	ASTM® D1003	97%
Tensile Strength	ASTM D882	1885 psi (13 mPa)
Elongation	ASTM D882	300%
Elastic Modulus	ASTM D882	50.8kpsi (350 mPa)
Oxygen (O2) Transmission	ASTM D3985	<0.05cc/m2/atm/24hrs
Carbon Dioxide (CO2) Transmission	ASTM F2476	<0.2cc/m2/atm/24hrs
Moisture Permeability	ASTM F1249	0.32 g/m2/24hrs.
Temperature Range		-4 to 60°C
Sterilization Range		25kGy to 50kGy

## BIOCOMPATIBILITY DATA

Property	Test Method	Values (Post gamma irradiation @ min. 25kGy)
Intracutaneous Toxicity	USP <88> Class VI	Passed
Acute Systemic Toxicity	USP <88> Class VI	Passed
Muscle Implantation	USP <88> Class VI	Passed
Cytotoxicity	USP 26 <87>	Passed
Bacterial Endotoxin	USP 26 <85>	Passed
Heavy Metals	USP 26 <661>	Passed
Buffering Capacity	USP 26 <661>	Passed
Non Volatile Residue	USP 26 <661>	Passed
Hemolysis	ISO 10993-4	Passed

# QUICK DELIVERY

---



Most of our customers receive the products they ordered 4-6 weeks after placing the order. This time is reflective of a product that receives gamma irradiation and utilizes common components. This time, however, may vary depending on the type of product ordered. For products that do not receive gamma irradiation the delivery time may be shorter while products that use uncommon fittings will take longer to process during the initial order. However, once we are aware of the specific fittings you would like on your single-use product, we can make sure we keep them stocked on the shelf for a quicker delivery time.

## OVERNIGHT

The second law of thermodynamics states that the total entropy can only increase over time for an isolated system. We understand that things can sometimes get chaotic. And in those times, we are here to help. For non-irradiated product, our streamlined processes means you can have your product delivered by brunch time the day after you order it. And while this is an expedited process, it goes to show that we will work to get you what you want exactly when you need it.

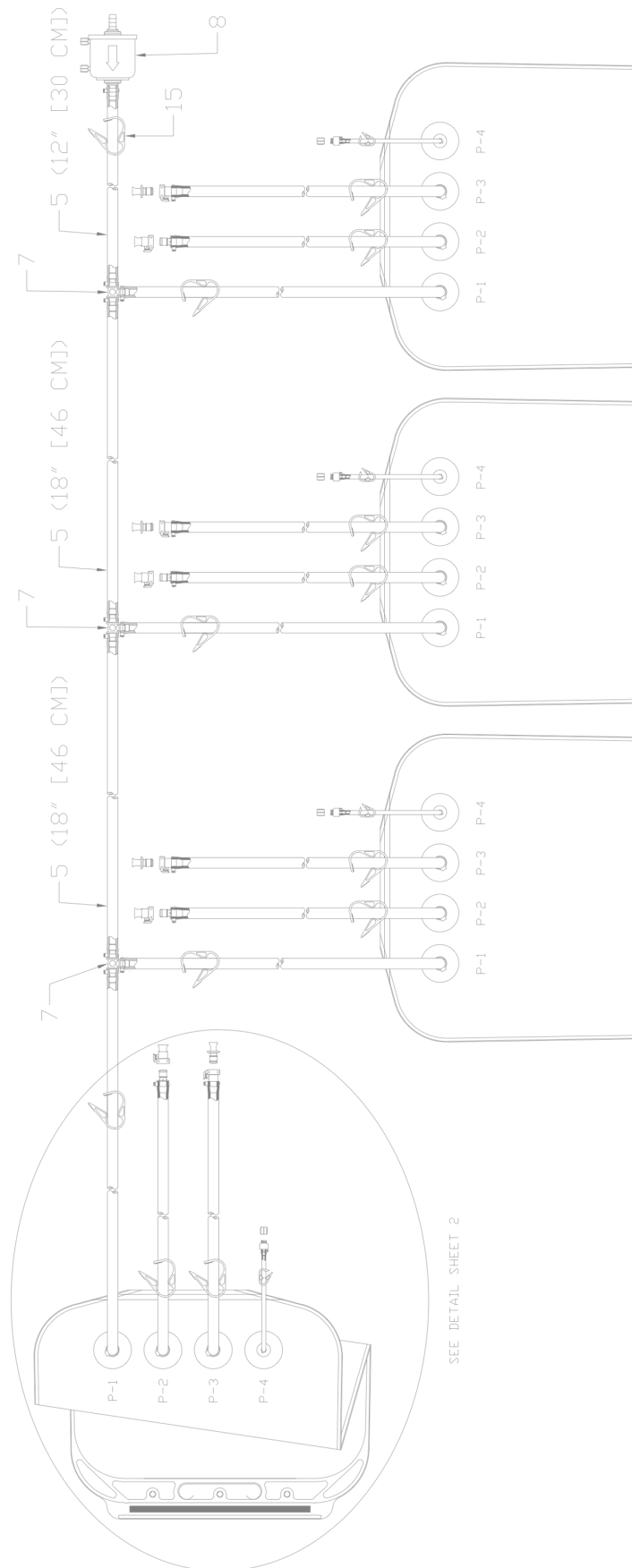



**OUR PRODUCTS ARE PROUDLY MANUFACTURED IN THE USA**

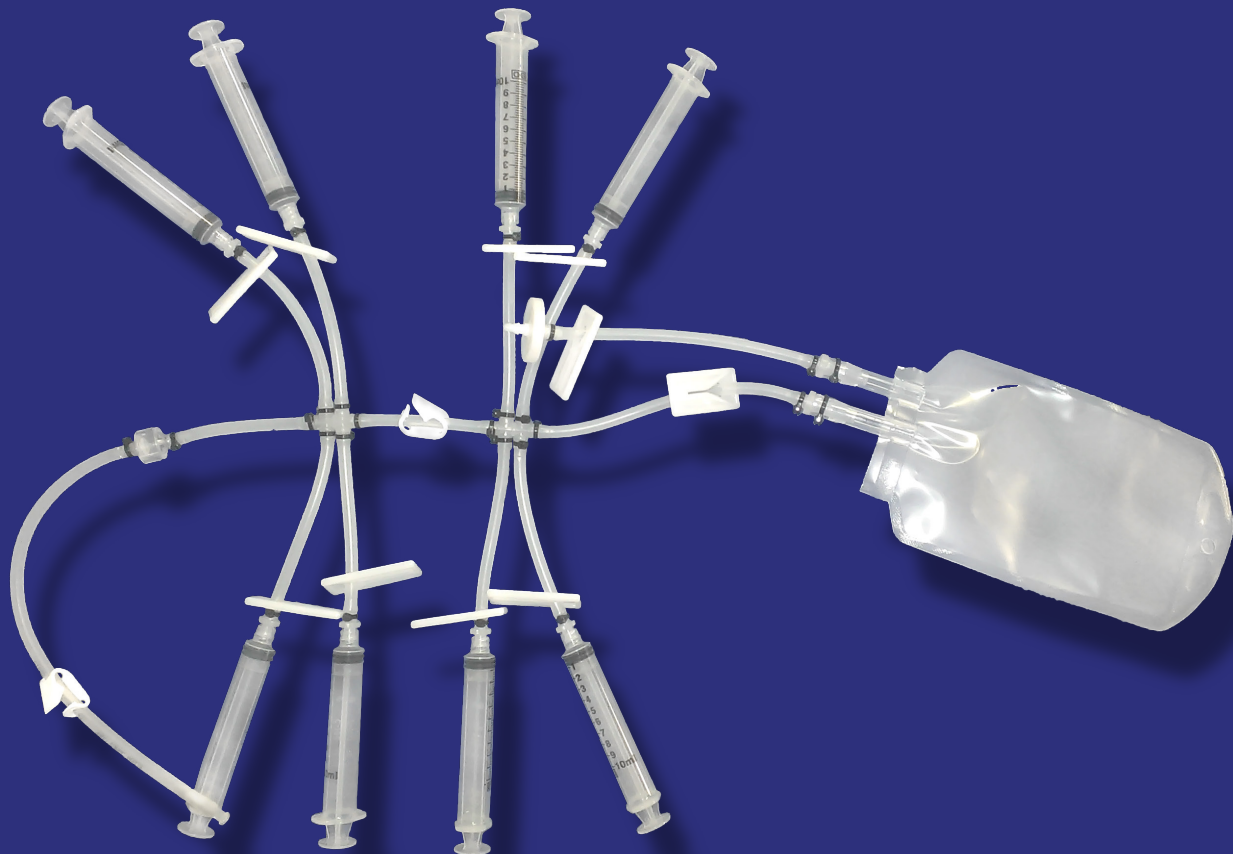

---

291 U.S. Highway 22 East Bldg 8, Lebanon, NJ 08833  
Tel: (908) 300-3244 • Fax: (908) 300-3244 • [www.flexbiosys.com](http://www.flexbiosys.com)