

INSTALLATION

4.3 ELECTRICAL INSTALLATION

4.3.1 Electrical Connections

All ranges of Searchline Excel comply with the EMC requirements EN50081 and EN50082. In order to maintain compliance with these standards it is essential that the electrical installation of Excel is engineered correctly.

Electrical installation standards vary for different countries, companies and applications and it is the responsibility of the installation design authority to determine the applicable standards and ensure compliance with them. When designing electrical installations for Excel, Zellweger Analytics Limited recommends that the installation design authority considers the following:

1. Where possible, the unit cases should not be electrically connected to electrically noisy (*dirty*) metalwork or conductors. An electrical isolation kit is supplied (see Technical Handbook) to provide the required electrical isolation between the unit's mountings and its mounting plate. The case is internally connected to the green/yellow GND wire which should preferably be connected to a low noise (*clean*) earth line. See also 5 of this section.
2. The entire length of the field cabling connected to each unit should be fully shielded with the shield connected to a low noise (*clean*) earth line.
3. The low noise (*clean*) earth line should only be connected to safety earth (usually *dirty*) at a single point. This connection should be made in such a manner that it does not introduce noise onto the low noise earth. Star earthing arrangements minimise earth current crosstalk.
4. The shields of the field cabling should not be connected such that earth loops are produced, or in a manner that will result in the shields carrying large currents from heavy plant or equipment.
5. Ideally, the field cable shield should be connected to the unit's green/yellow GND wire, providing a single, continuous earth shield. This connection **must not** be allowed to complete an earth loop.

11

INSTALLATION

6. The earth bonding arrangement must ensure that the maximum peak voltage between the unit case earth and any field cable conductor is less than 350V. Voltages in excess of this can cause permanent damage to the unit's RFI protection filters.
7. The use of a single, screened cable for each gas detector ensures maximum screening and minimum crosstalk. Cabling arrangements which use a single cable for connecting a number of field devices compromise screening, increase the potential for crosstalk and prevent implementation of true star earthing.
8. Any electrical interference induced onto the 4-20mA loop conductors by the installation must be kept below the levels necessary to comply with the general requirements of EN50054. In practice, this means that peak noise currents induced on the current loop should be no greater than $\pm 0.25\text{mA}$.
9. The 0V rail of the control card/control system is often directly connected to one side of the 4-20mA current sensing resistor. Electrical noise on such a rail is, therefore, directly connected to the 4-20mA input. In order to avoid additional noise being induced on the 0V rail, it should not be commoned with the safety earth/ground, which frequently carries a high level of electrical noise.
10. All electrical equipment connected to the system should comply with EN50081 and EN50082.
11. The 24V supply should be free from large transients and fluctuations. This corresponds to a maximum round loop impedance of 8.25 ohms for a nominal 24V system supply.
13. Receivers should not be installed in close proximity to the antennae of high powered radios, radar and satellite communication equipment.

12

INSTALLATION

4.3.2 Electrical Installation

1. Isolate all associated power supplies and ensure that they remain **OFF** during this procedure.
2. Fit approved cable glands to the junction box cable entries to be used for field wiring, using sealing washers where necessary to maintain ingress protection rating.
3. Fit approved blanking plugs to all unused cable entries.
4. Make appropriate electrical connections as shown in the following diagrams.
5. The mounting plate must be bonded to a protective earth, either through contact with the duct wall (if it is itself suitably earthed) or by direct connection.

Note: Suitable crimps or ferrules must be fitted when connecting more than one wire to a single terminal.

4.3.3 Transmitter and Receiver Connections via DVC100

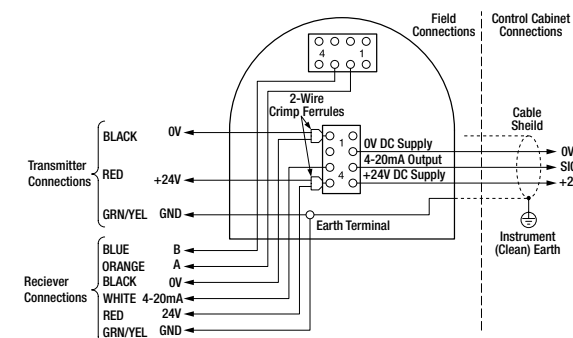

13

4.3.4 Transmitter and Receiver Connections UL (DX100)

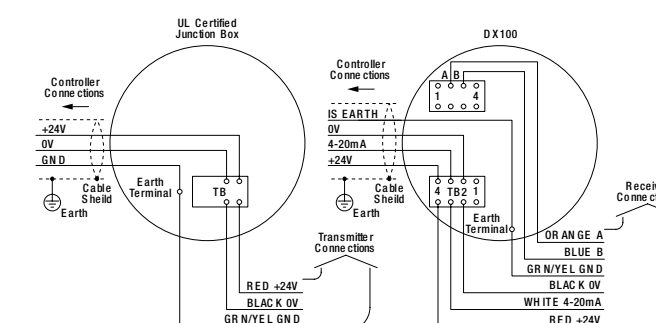

14

4.3.5 Transmitter and Receiver Connections (Non DVC/DX100)

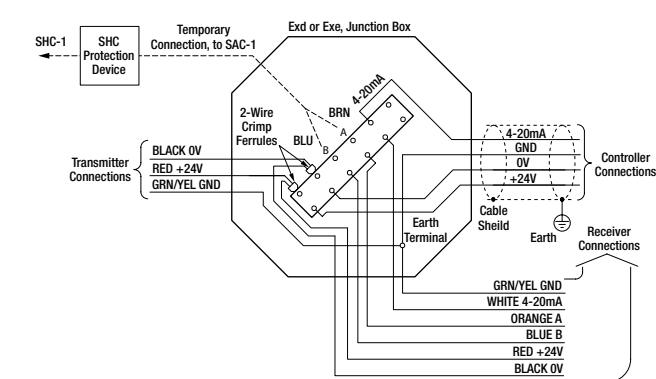

Installation Guide



CONTENTS

1. INTRODUCTION



Searchline Excel
Cross-duct Infrared Gas Detector

1. Introduction	2
2. Safety	3
3. Mechanical Assembly	4
3.1 General	4
3.2 Transmitter and Receiver	4
3.3 Short Range Retro-Reflector	6
3.4 Long Range Retro-Reflector	6
4. Installation	7
4.1 General	7
4.2 Mechanical Installation	7
4.3 Electrical Installation	11
4.3.1 Electrical Connections	11
4.3.2 Electrical Installation	13
4.3.3 Transmitter and Receiver Connections via DVC100	13
4.3.4 Transmitter and Receiver Connections UL (DX100)	14
4.3.5 Transmitter and Receiver Connections (Non DVC/DX100)	14

This guide provides the installation personnel with the basic information necessary to mechanically install the Searchline Excel system units and make the necessary electrical connections.

This guide is not intended to replace the associated Searchline Excel Technical Handbook (2104M0505) which contains the full safety, installation, commissioning, maintenance and fault finding instructions.

These procedures assume that consideration of the location and mounting of the system units has already been taken into account in accordance with the guidelines in the Technical Handbook.

The following diagram shows a typical system configuration and identifies the main parts.

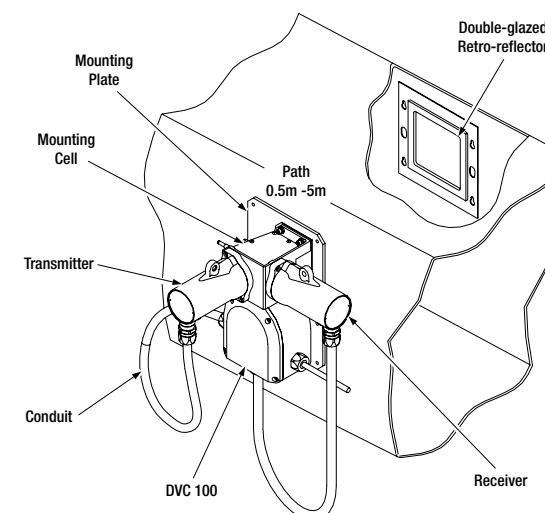

2

Find out more
www.honeywellanalytics.com

Contact Honeywell Analytics:

Europe, Middle East, Africa
Life Safety Distribution AG
Wilstrasse 11-U31
CH-8610 Uster
Switzerland
Tel: +41 (0)44 943 4300
Fax: +41 (0)44 943 4398
gasdetection@honeywell.com

Americas
Honeywell Analytics Distribution, Inc.
405 Barclay Blvd.
Lincolnshire, IL 60069
USA
Tel: +1 847 955 8200
Toll free: +1 800 538 0363
Fax: +1 847 955 8208
detectgas@honeywell.com

Asia Pacific
Honeywell Analytics Asia Pacific
#508, Kolon Science Valley (1)
187-10 Guro-Dong, Guro-Gu
Seoul, 152-050,
Korea
Tel: +82 (0)2 2025 0307
Fax: +82 (0)2 2025 0329
analytics.ap@honeywell.com

Technical Services
ha.emea.service@honeywell.com

www.honeywell.com

Issue 01 - 12/2005
H_MAN0593_2104M0511
09-07
© 2007 Honeywell Analytics



11064

1

2. SAFETY

Ensure that you read and understand these instructions **BEFORE** handling or operating the equipment.

Please pay particular attention to the Safety Warnings.

WARNINGS

The Searchline Excel System is certified for and intended for use in potentially hazardous areas. Install and use the Searchline Excel System in accordance with the latest regulations.

For installations in the UK, the Code of Practice SELECTION, INSTALLATION AND MAINTENANCE OF ELECTRICAL APPARATUS FOR USE IN POTENTIALLY EXPLOSIVE ATMOSPHERES should be strictly observed. General recommendations are given in BS5345: Part 1:1989. Specific requirements for flameproof (Type 'd'), intrinsically safe (Type 'I') and increased safety (Type 'e') protection are given in BS 5345: Part 3: 1979, BS 5345:Part 4:1977 and BS 5345: Part 6:1978 respectively.

For installations in North America, the national Electrical Code (NFPA 70 - 1990) or later issues should be strictly observed.

Elsewhere, the appropriate local or national regulations should be used.

The Code of Practice regarding SELECTION, INSTALLATION, USE AND MAINTENANCE OF APPARATUS FOR THE DETECTION OF COMBUSTIBLE GASES (OTHER THAN FOR MINING APPLICATIONS OR EXPLOSIVE PROCESSING AND MANUFACTURE) must be complied with. Refer to BS6959:1988 in the UK or the appropriate local or national regulations.

Honeywell Analytics Limited reserves the right to change or revise the information supplied in this document without notice and without obligation to notify any person or organisation of such revision or change. If further details are required that do not appear in this document, contact Honeywell Analytics Limited or one of its agents.

3

3. MECHANICAL ASSEMBLY

3.1 GENERAL

This section details the mechanical assembly information and important dimensions necessary for installing the system units.

3.2 TRANSMITTER AND RECEIVER

CENELEC TX/RX Configuration

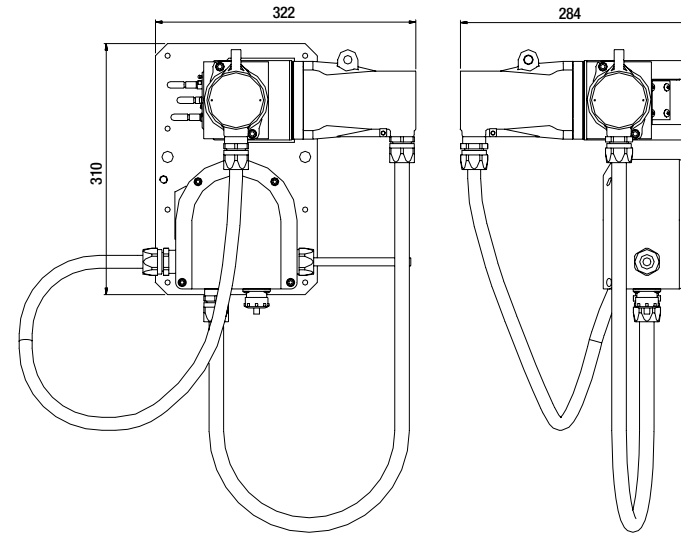

4

MECHANICAL ASSEMBLY

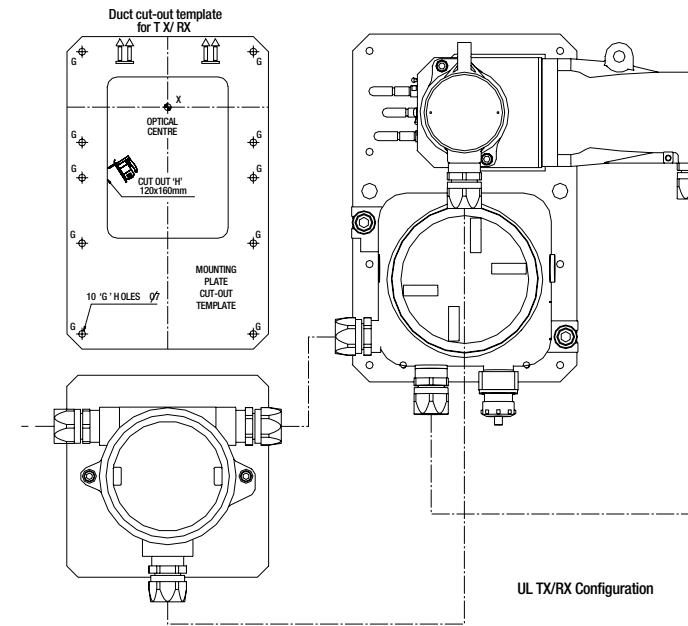

5

MECHANICAL ASSEMBLY

3.3 SHORT RANGE RETRO-REFLECTOR

The short range retro-reflector is suitable for use from 0.5m to 2.5m.

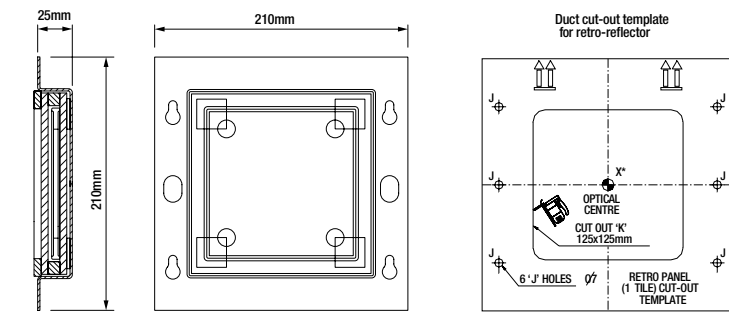

6

3.4 LONG RANGE RETRO-REFLECTOR

The long range retro-reflector is suitable for use from 1m to 5m.

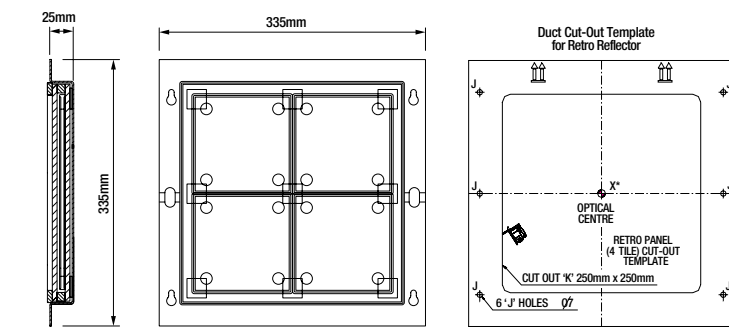

6

4. INSTALLATION

4.1 GENERAL

Searchline Excel is designed to allow installation to be performed by a single operator.

The installation procedure is split into mechanical installation and electrical installation. The transmitter and receiver assembly needs to be fully assembled and mounted to the duct structure before making the electrical connections.

4.2 MECHANICAL INSTALLATION

Select the location on the duct where the Searchline Excel system will be mounted. There must be sufficient clearance to enable the retroreflector to be mounted directly opposite the transmitter and receiver assembly. Ensure that the duct structure is sufficiently rigid to support the weight of the Searchline Excel system without sagging. Fit additional supports prior to installation if necessary.

Verify that the equipment to be installed is correct for the type of installation required (i.e., short/long range and normal/high temperature).

4.2.1 Transmitter and Receiver

1. Stick the mounting plate cut-out template onto the duct wall in the position chosen for the transmitter/receiver unit.

Note: The intersection of the bold horizontal and vertical lines on the template (Point X) corresponds to the centre of the unit's IR beam.

2. Drill 10 mounting holes (7mm diameter) in the positions marked G on the template.
3. Following outline H, cut a rectangular aperture in the duct wall.
4. Check that the path from the aperture to the opposite wall of the duct is clear and unobstructed.

7

INSTALLATION

5. Measure the distance (metres) between the two walls of the duct. This distance will be required for commissioning.

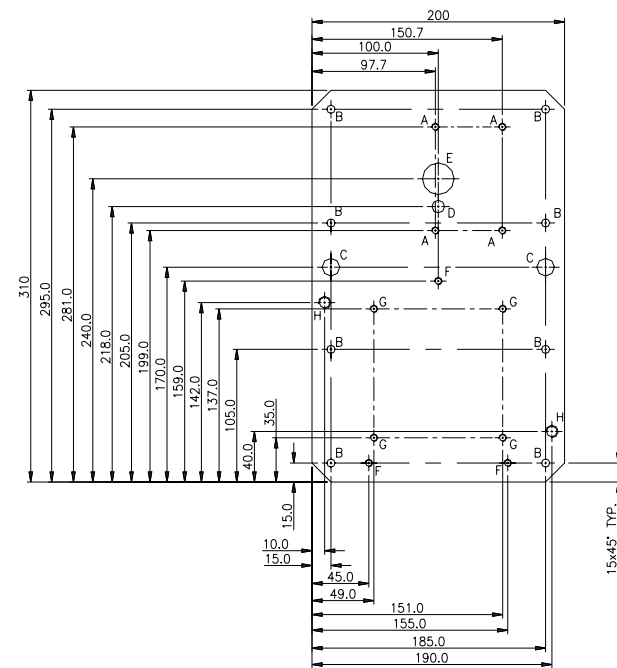

8

INSTALLATION

Identity	Quantity	Size	Used For
A	4	M6 tapped	Mounting cell mounting.
B	8	Ø 6.5mm	Mounting plate to support bar mounting.
C	2	Ø 14mm	Clearance for support bar fixing nuts.
D	1	Ø 10mm	Drain for mounting cell.
E	1	Ø 25mm	Cross duct optical measurement path.
F	3	M6 tapped	DVC100 mounting.
G	4	M6 tapped	BARTEC terminal box fixing
H	2	M10 tapped	DX100 fixing

7. Attach the mounting plate, mounting cell and junction box assembly to the duct wall using M6 x 16 cap head screws and washers.
8. Place an O ring in the groove on the right hand face of the mounting cell.
9. Attach the receiver unit to the right hand face of the mounting cell, making sure that its flange is flush with the cell's face. (Take care not to pinch the O ring between the mounting surfaces.)
10. Run the receiver's conduit into the chosen junction box's cable entry.
11. Repeating steps 8 to 10, attach the transmitter to the front face of the mounting cell.

4.2.2 Retro-reflector

1. Stick the retro-reflector cut-out template to the outside of the duct wall opposite the transmitter/receiver, ensuring that point X* is directly opposite point X on the other template. (This will ensure that the transmitter's IR beam hits the centre of the retro-reflector.)

9

INSTALLATION

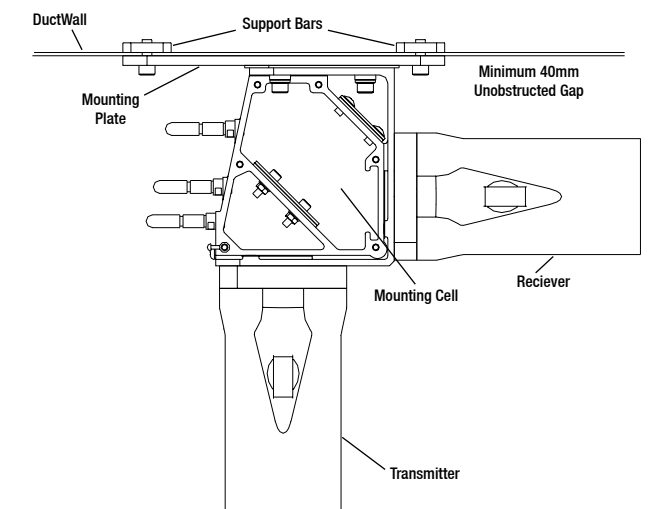

2. Drill 6 mounting holes (7mm diameter) in the positions marked J on the template.
3. Following outline K, cut a square aperture in the duct wall.
4. Insert the two retro-reflector panel support bars through the aperture and attach them to the inside of the duct using M6 washers and nuts. Ensure that the threaded holes in the support bars line up with the holes drilled in the duct.
5. Fit four M6 x 16 cap head screws into the holes in the support strips but do not tighten. Leave approximately 5mm of thread exposed on the outside of the duct.
6. Slot the retro-reflector assembly over the heads of the screws and allow its weight to be supported on the exposed sections of thread. Tighten the four screws to clamp the retro-reflector assembly in position.

10