

Assembly View (representative structure)

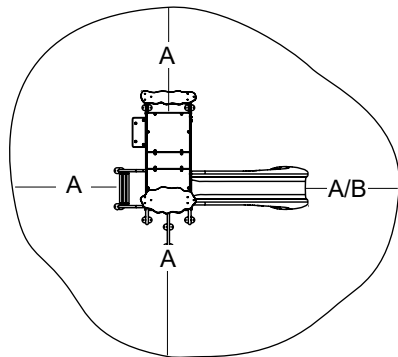

Equipment Use Zone
A - ASTM: at least 72 in. (1830 mm)
 CSA: at least 1800 mm
 EN: at least 1500 mm
 and **B** - 2000 mm at slide exits







Installation Instructions

Playworld Systems[®]
 Models XX0474 and XX0474S
 PlayTown Playground
 In-Ground and Surface Mount

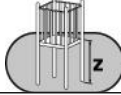
Installation Preparation

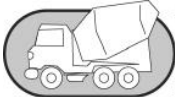
Recommended Crew: Two (2) adults
 Installation Time: 7.5 man-hours (in-ground)
 Installation Time: 2 man-hours (surface mount)
 Concrete Required: 0.33 cubic yard (0,22 cubic meters)
 Use Zone: Refer to the information below
 User Group Age (years): ASTM/CSA: 2-12, EN: 2-14

ICON KEY

	Fully Tighten Hardware		Critical Fall Height
	Do Not Fully Tighten Hardware		Pour Concrete
	Drill		Dig Footing Holes
	Hammer		

Installation Instructions

KEY	
Position #	Unit of Measurement
Top #	Inches
Bottom #	[Millimeters]

Top View

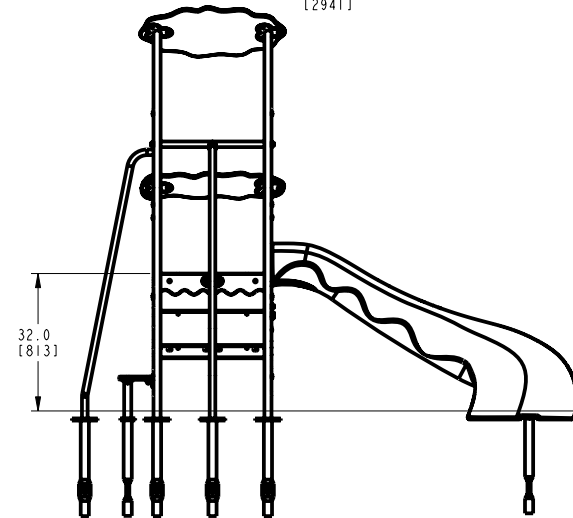
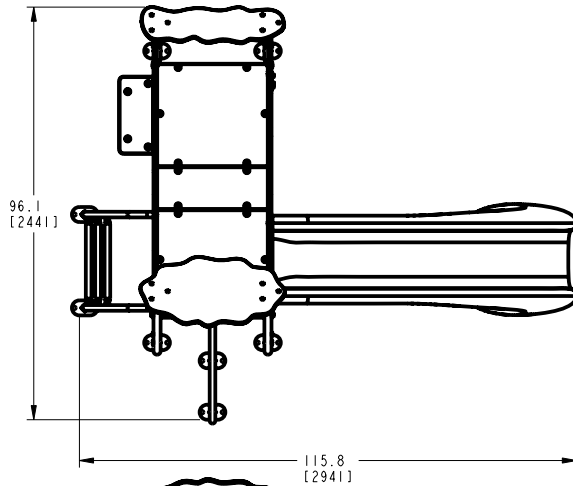

Elevation Views
XX0474

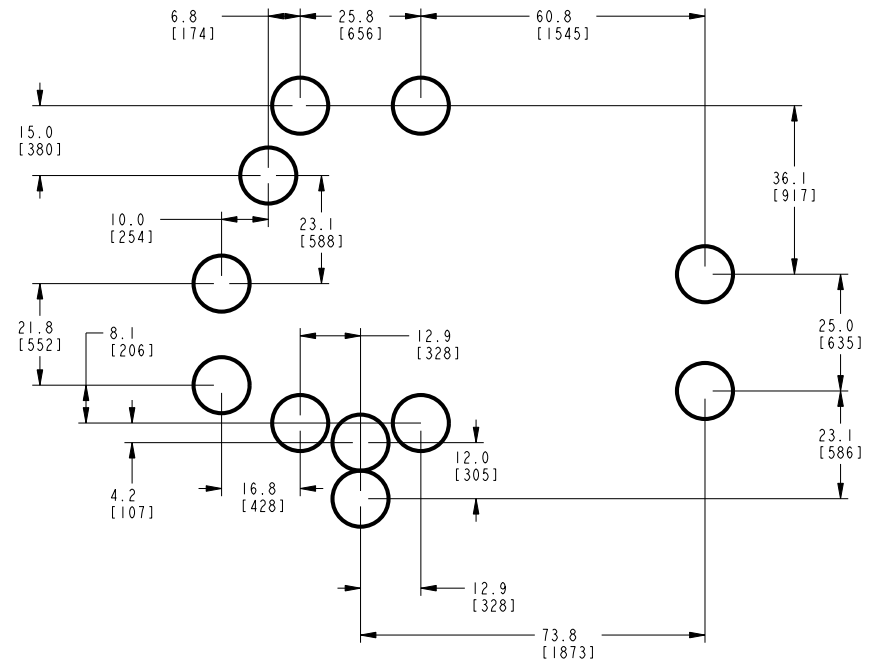
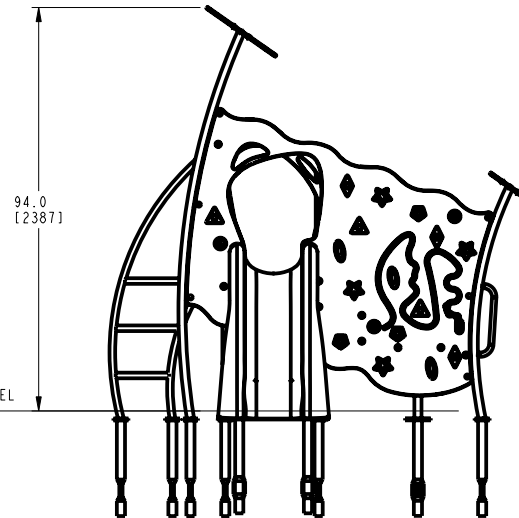

Footing Diagram

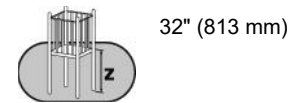

Installation Instructions

KEY	
Position	Unit of Measurement
Top #	Inches
Bottom #	[Millimeters]

Top View

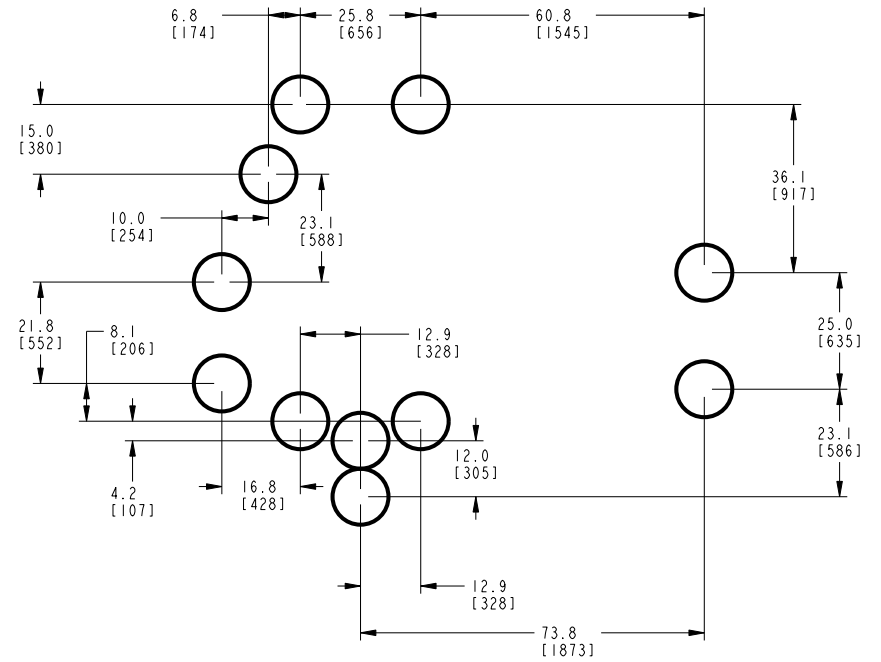
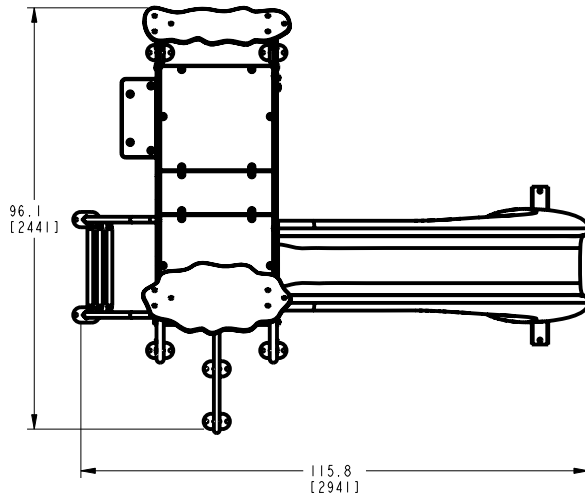

Footing Diagram

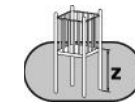
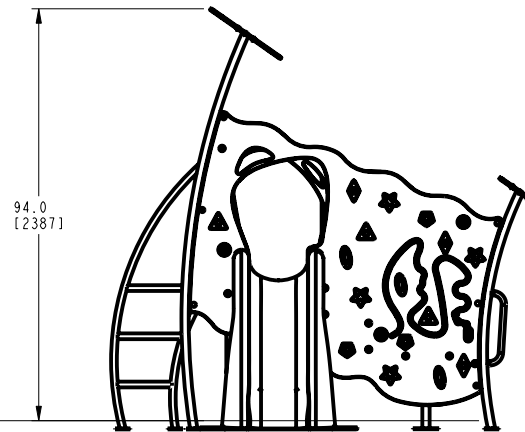
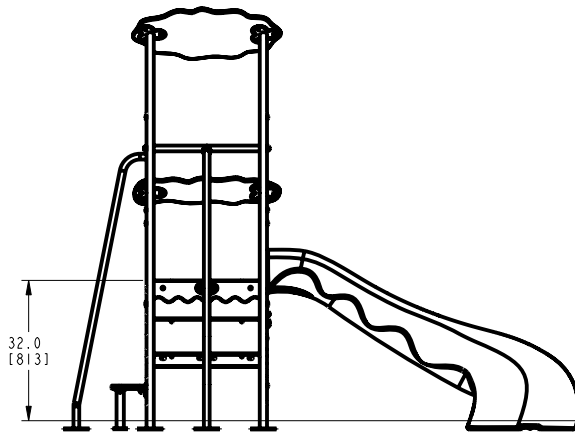

32" (813 mm)

Elevation Views
XX0474S

Installation Instructions

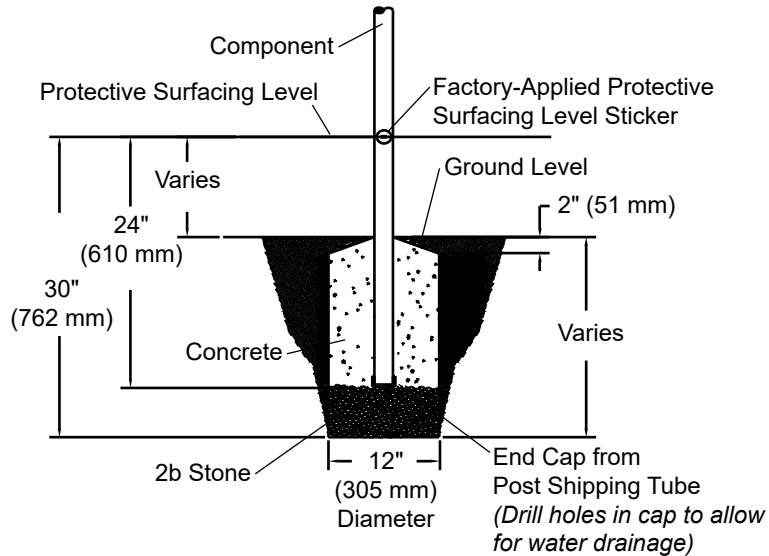

Component Footing Detail (ASTM/CSA)

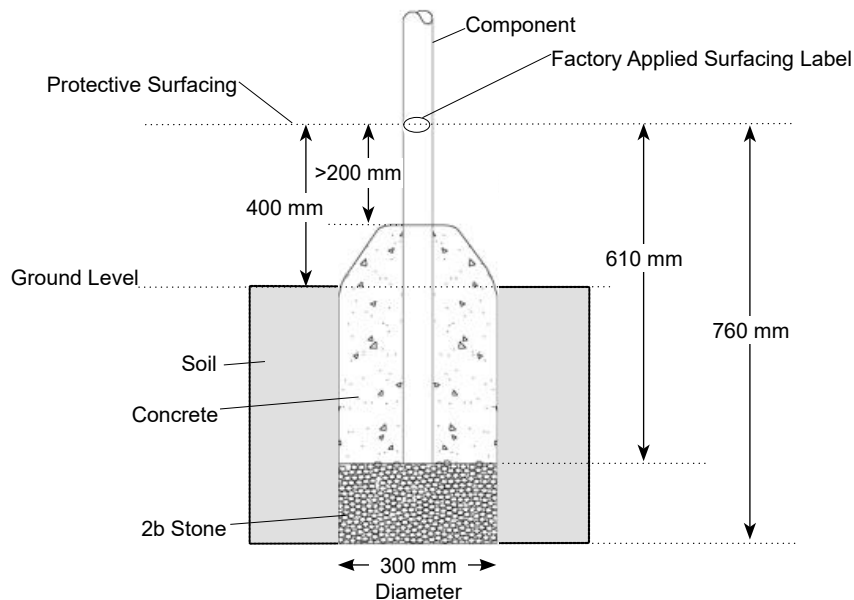

Footing Detail Component Post (EN)

FOOTING NOTES

- Component footing depth equals 30 in. (762 mm) less the depth of the protective surfacing material. The post is designed to have 12" (305 mm) in concrete.

Example: If 12 in. (305 mm) of wood mulch is used for surfacing, the footing depth would be 18 in. (457 mm).

- Most support posts and component support legs will have either a factory-applied sticker with line, or factory-applied mark designating protective surfacing level on a clear and level installation site.

- If play structure is installed on uneven terrain, maintain support post mark at protective surfacing level at lowest grade. Adjust other footings accordingly. Support posts and all attaching decks and play components must be plumb and level.

- Do not encase bottom of support post in concrete. Place post directly on packed stone.

- The footings shown on Playworld Systems' documentation are recommendations based on historical performance in average soil conditions. Footing dimensions may be modified by the owner based on actual soil conditions.

For example:

- If local soil is loose or unstable, a larger footing may be required.
- If local soil is considered stable, such as bedrock, clay or hard packed earth, a smaller footing may be used. Before changing footing dimensions, we strongly recommend that the footings be reviewed and approved by a registered engineer.

- Base of footing must be below frost line.

- Assemble the entire structure before pouring concrete unless specifically instructed to do so in the individual component installation instructions.

Installation Instructions

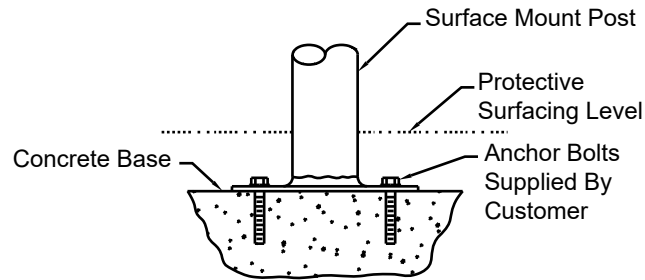

Surface Mount Footing Detail

FOOTING NOTES

- All support posts and component support legs may have either a factory-applied sticker with line, or factory-applied mark designating protective surfacing level on a clear and level installation site.
- If play structure is installed on uneven terrain, maintain support post mark at protective surfacing level at lowest grade. Adjust other footings accordingly. Support posts and all attaching decks and play components must be plumb and level.
- Footing size may vary due to local soil and weather conditions.
- Base of footing must be below frost line.
- Comparison of protective surfacing materials is available in [Handbook for Public Playground Safety](#) published by U. S. Consumer Product Safety Commission.

Surface mount hardware is not supplied. Customer is responsible for concrete base and providing surface mount hardware as specified by a registered structural engineer for each specific project application.

Installation Instructions

Follow the details in alphabetical order. For clarification, each detail references the step description. The step descriptions start on page 17.

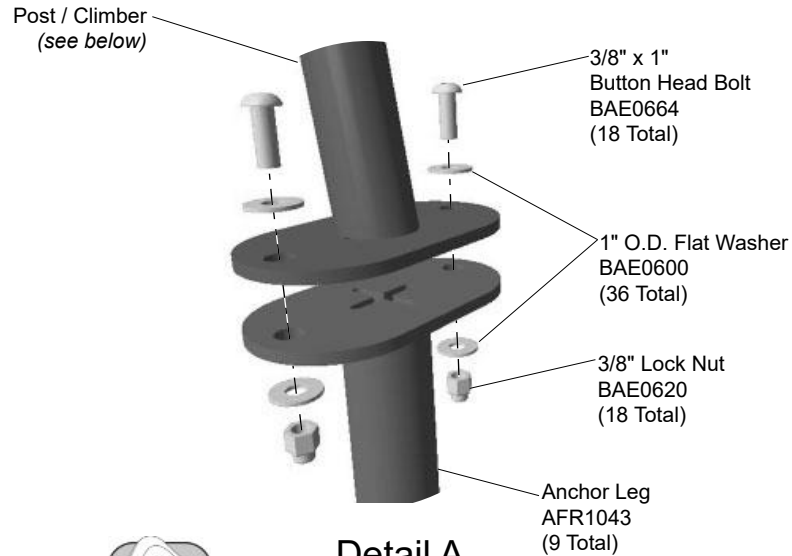

Detail A
Step 4
(in-ground model only)

Attach the anchor legs to the playground posts and climbers.

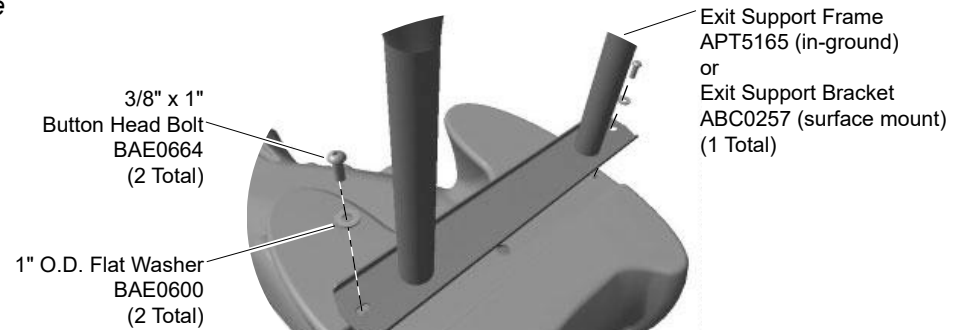

Note: Exit support bracket for the surface mount model is not shown but will attach in the same manner.



Detail B
Step 5

(in-ground model shown)
Attach the exit support frame / bracket to the straight slide.

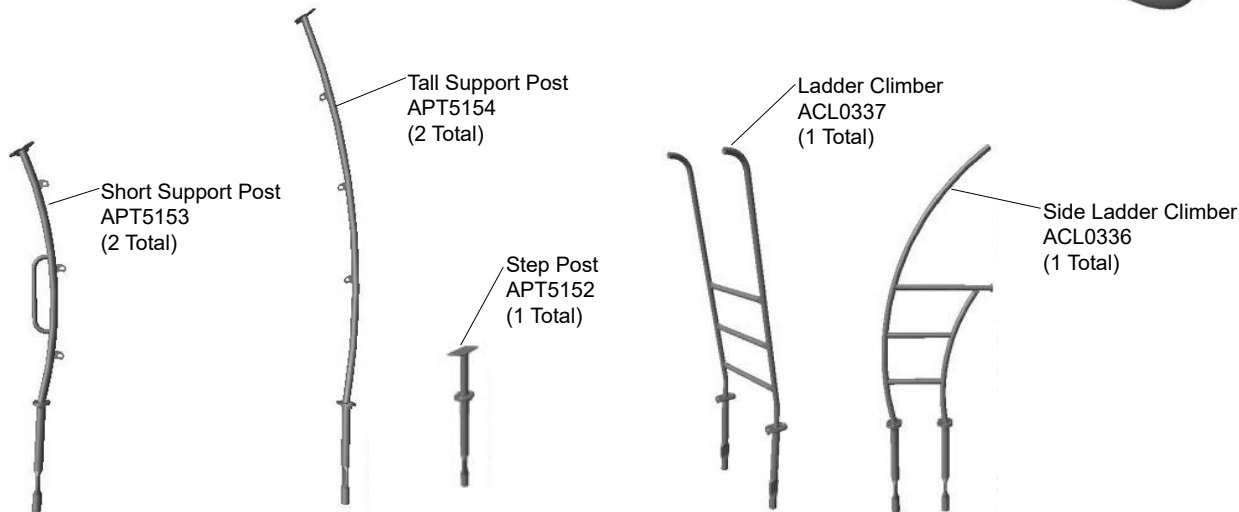

Installation Instructions

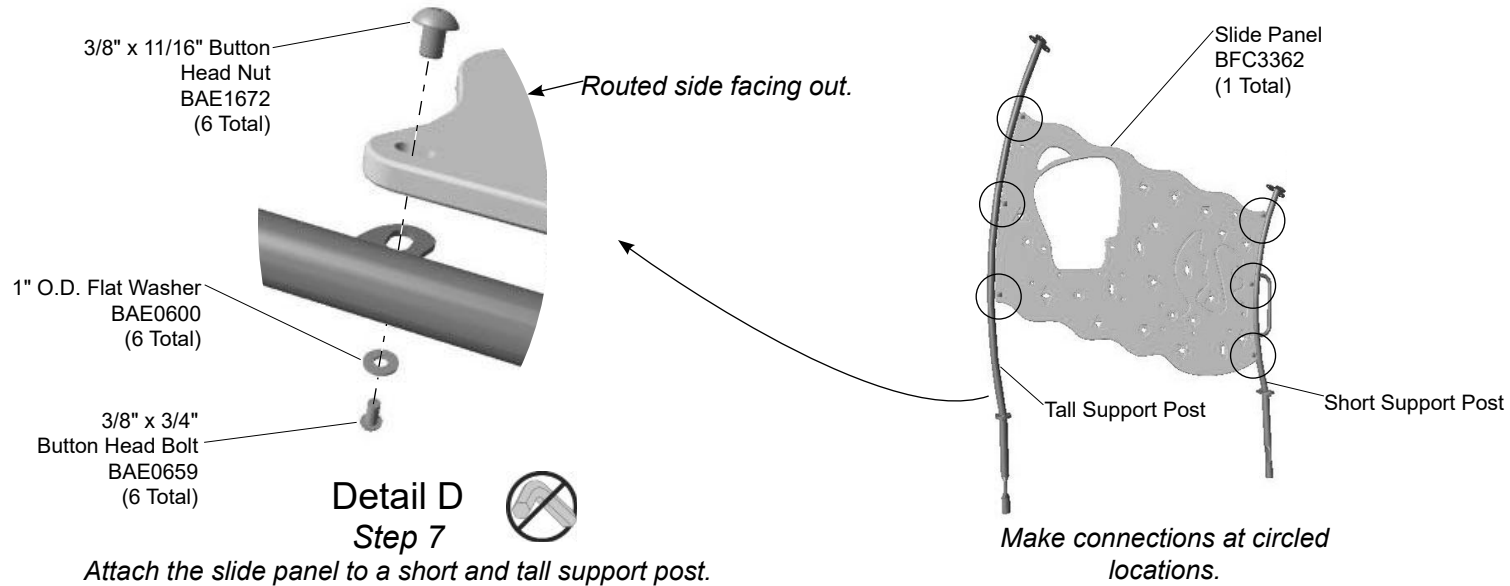
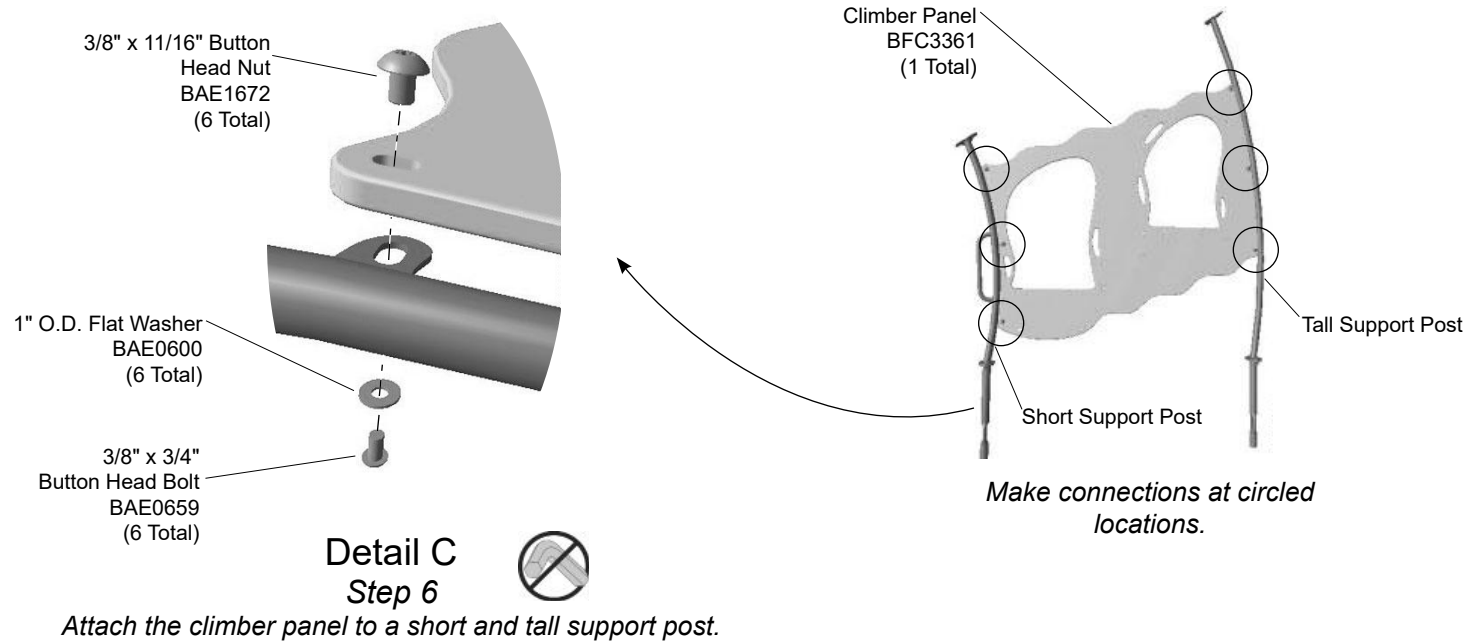

Installation Instructions

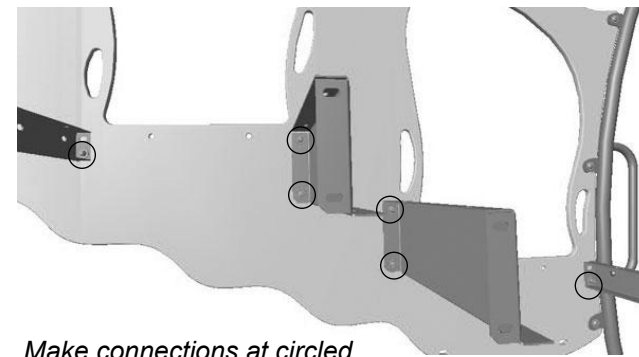
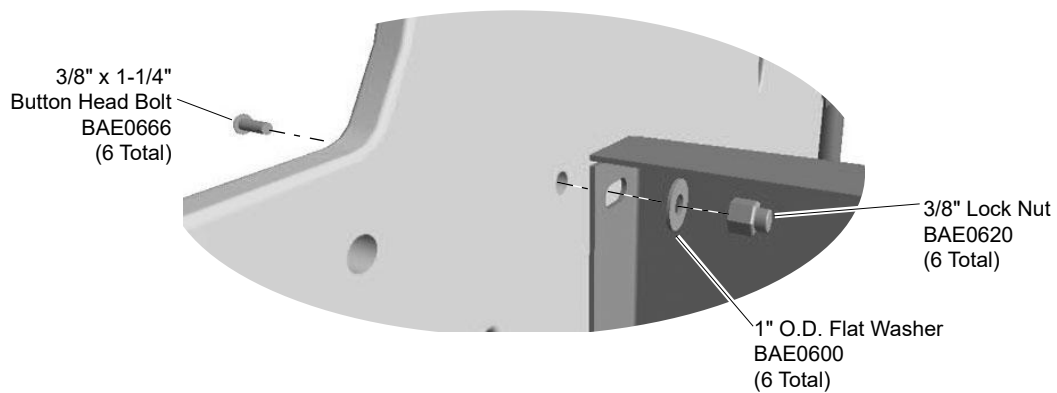
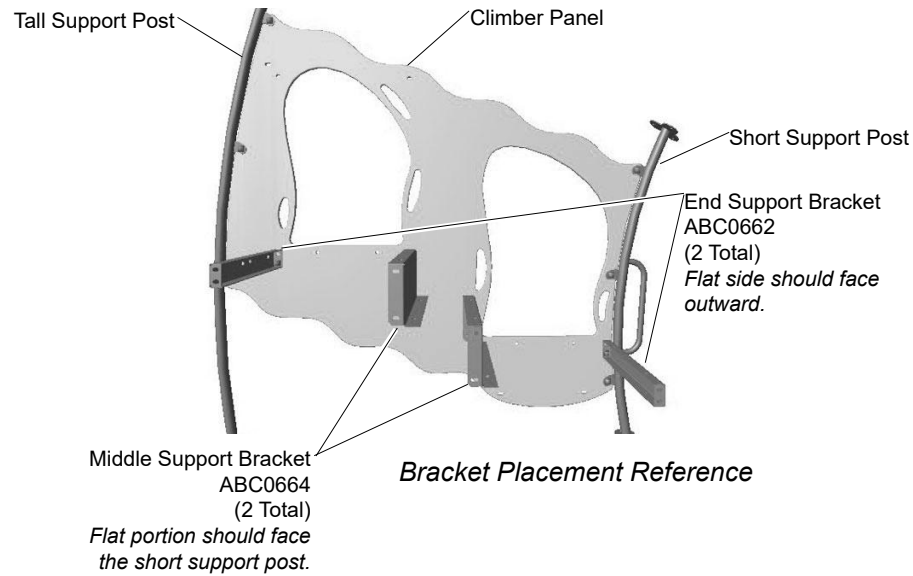

Detail E Step 8

Attach the support brackets to the climber panel.

Installation Instructions

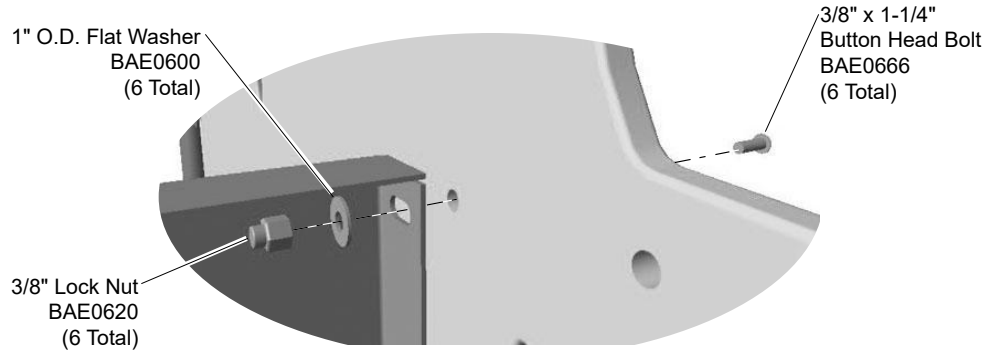

Detail F
Step 9



Attach the slide panel to the support brackets.

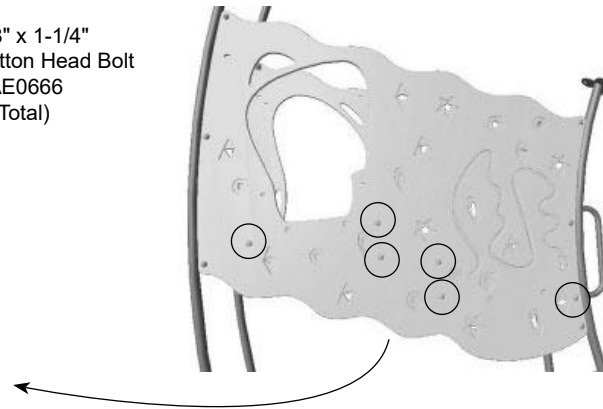

Stand panel assemblies up and place in, or on, their footings to make the connections.

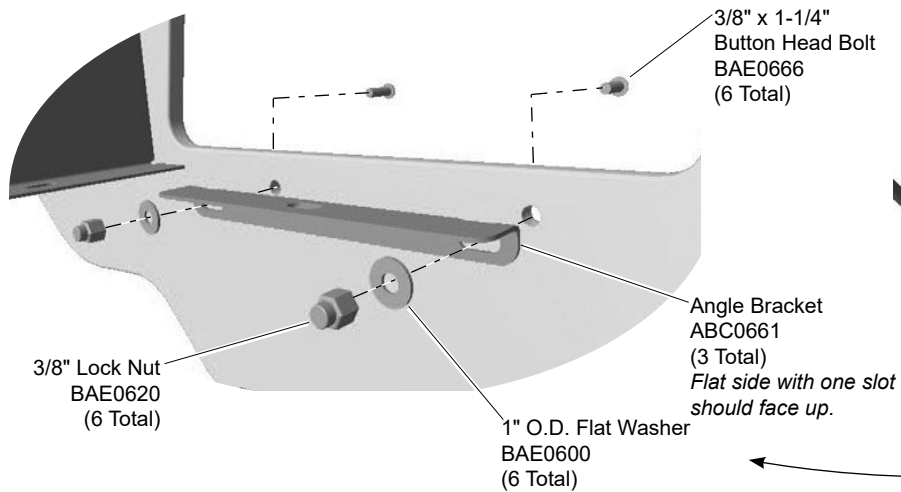

Detail G
Step 10



Attach the angle brackets to the panels.

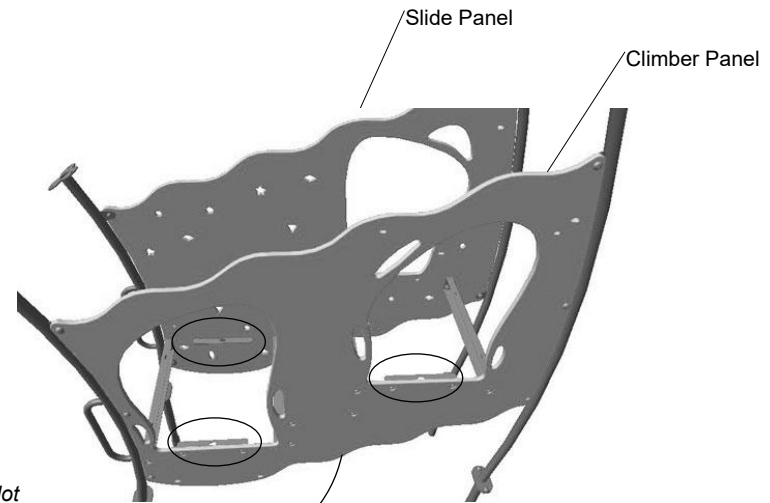

Note: there is a fourth bracket that will be attached later in the assembly. See Step 12 - Detail J.

Installation Instructions

Leave this hole open until Step 12.

Slide Panel

Large Platform Panel
BFC3368
(1 Total)
5 connections

Climber Panel

3/8" x 1-1/4"
Button Head Bolt
BAE0666
(15 Total)

The side of the panel with the
routed holes must face up.

1" O.D. Flat Washer
BAE0600
(15 Total)

3/8" Lock Nut
BAE0620
(15 Total)

Small Platform Panel
BFC3366
(1 Total)
4 connections

Large Platform Panel
BFC3368
(1 Total)
6 connections

Detail H
Step 11



Attach the plastic platforms to the brackets.
See references at right for connection points.

Installation Instructions

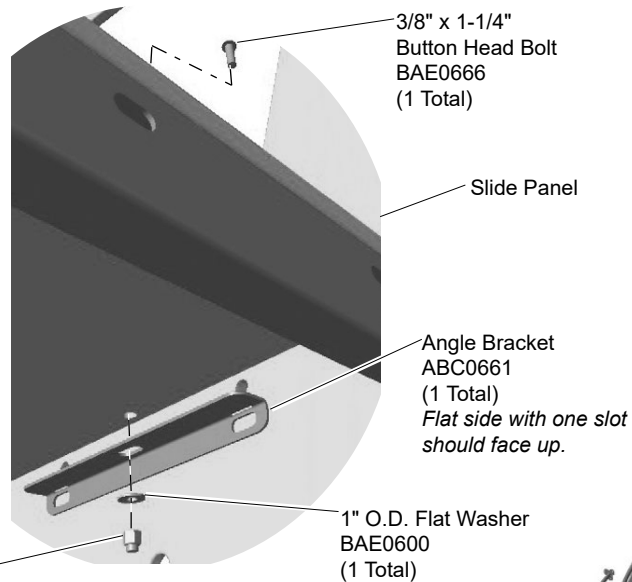

3/8" Lock Nut
BAE0620
(1 Total)

Detail J Step 12



Attach the remaining angle bracket to the slide panel.
This is the bracket the slide will attach to in the next step.

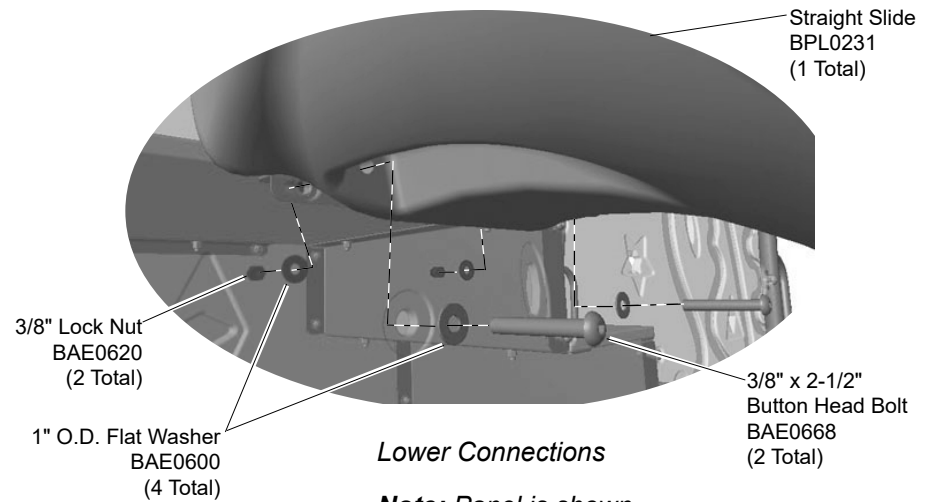
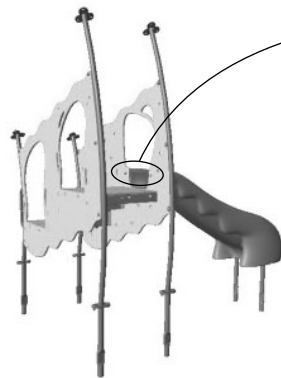
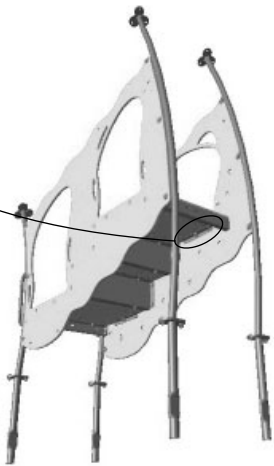

Lower Connections

Note: Panel is shown transparent for ease of viewing the connections.

Detail K-1

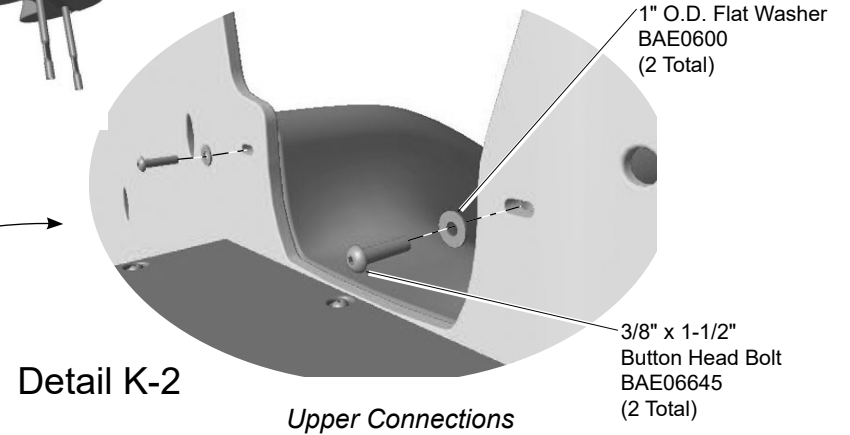

Upper Connections

Detail K-2

Details K-1 and K-2 Step 13



Attach the straight slide to the slide panel.

Installation Instructions

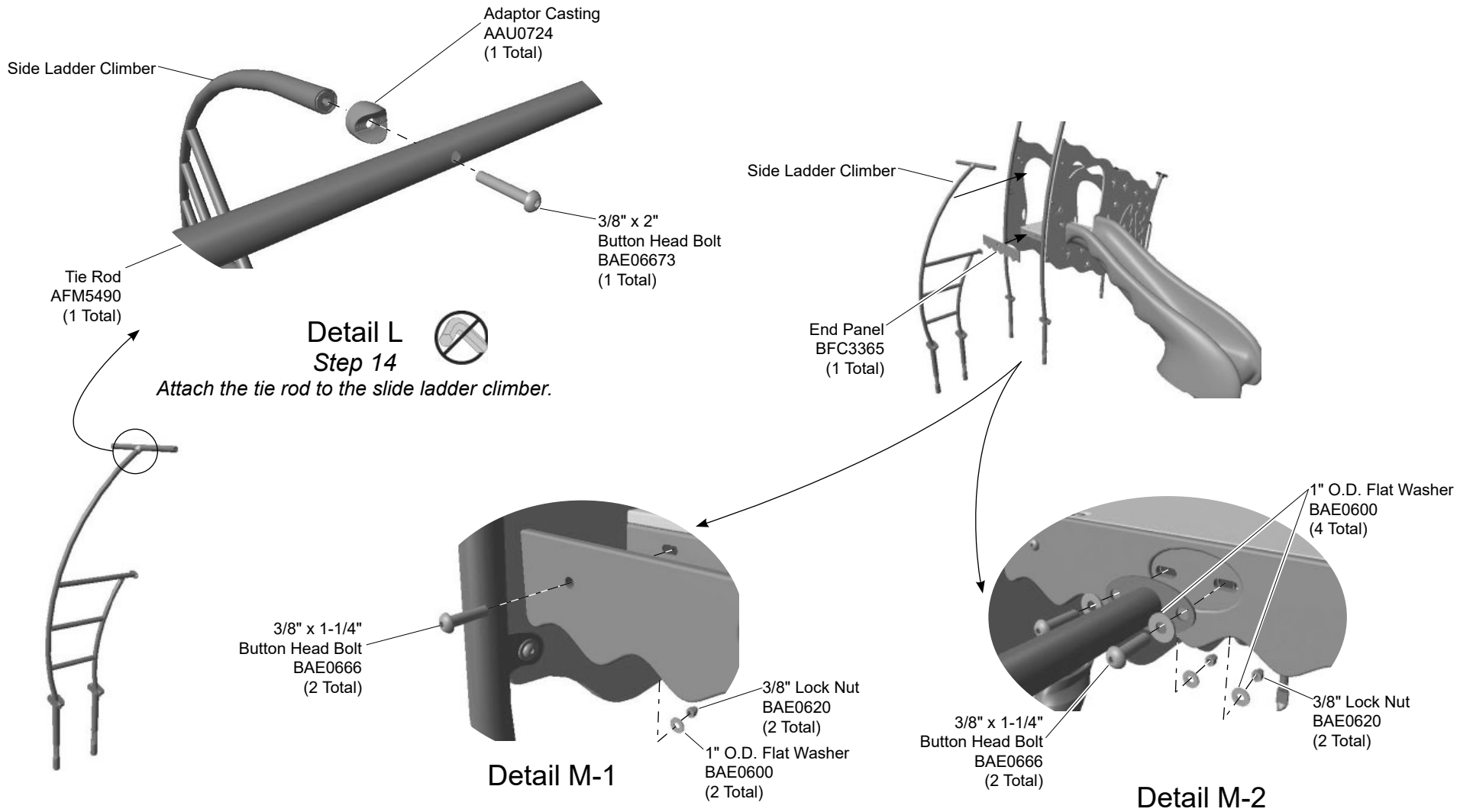

Details M-1 and M-2

Step 15

Attach the slide ladder climber and end panel to the playground assembly.

Installation Instructions

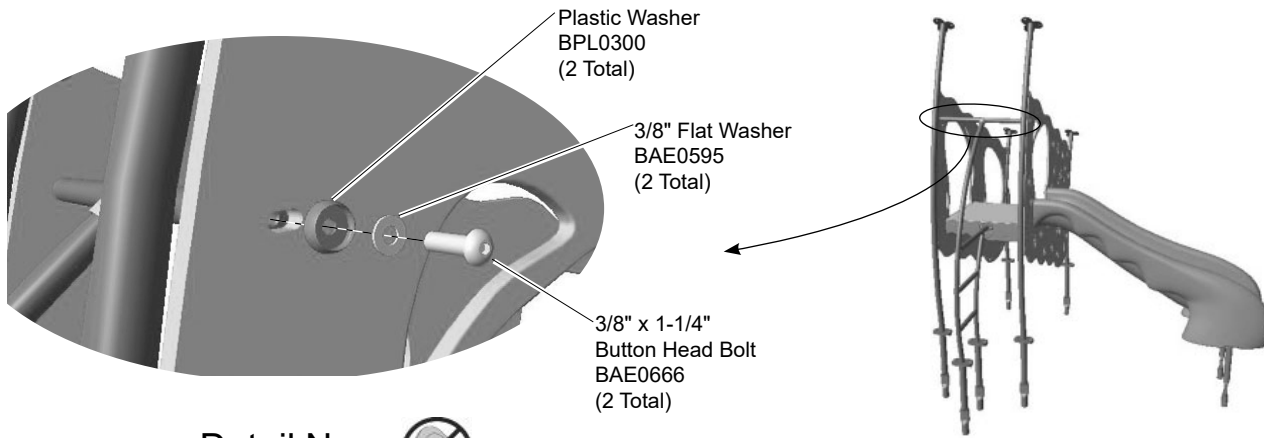

Plastic Washer
BPL0300
(2 Total)

3/8" Flat Washer
BAE0595
(2 Total)

3/8" x 1-1/4"
Button Head Bolt
BAE0666
(2 Total)

Detail N
Step 16



Attach the tie rod to the slide and climber panels.

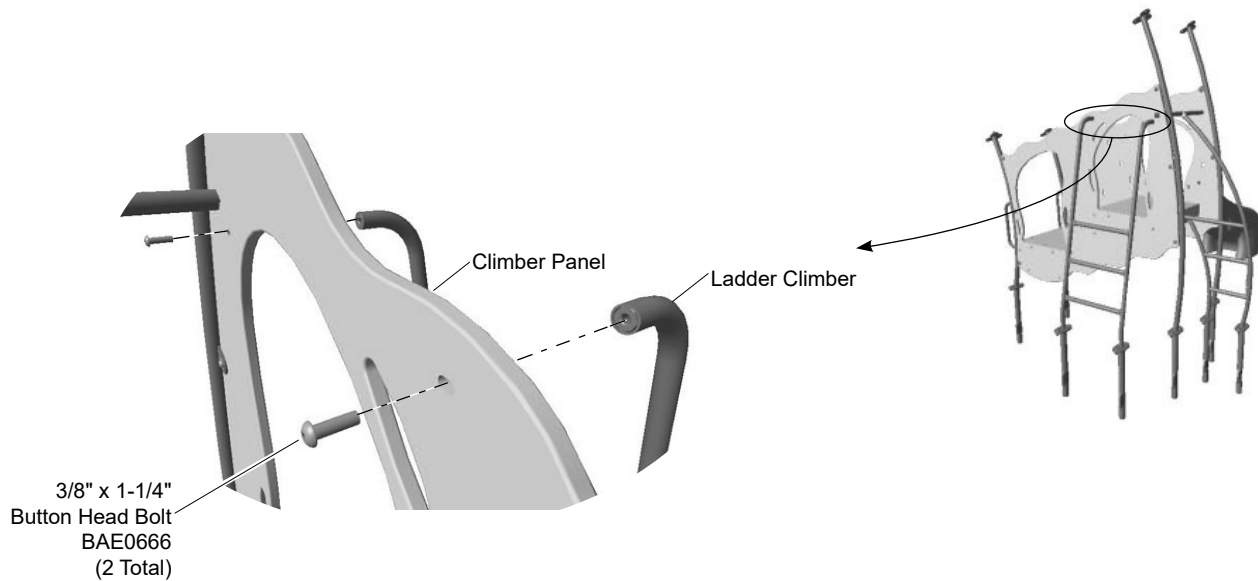

Climber Panel
Ladder Climber

3/8" x 1-1/4"
Button Head Bolt
BAE0666
(2 Total)

Detail O
Step 17



Attach the ladder climber to the climber panel.

Installation Instructions

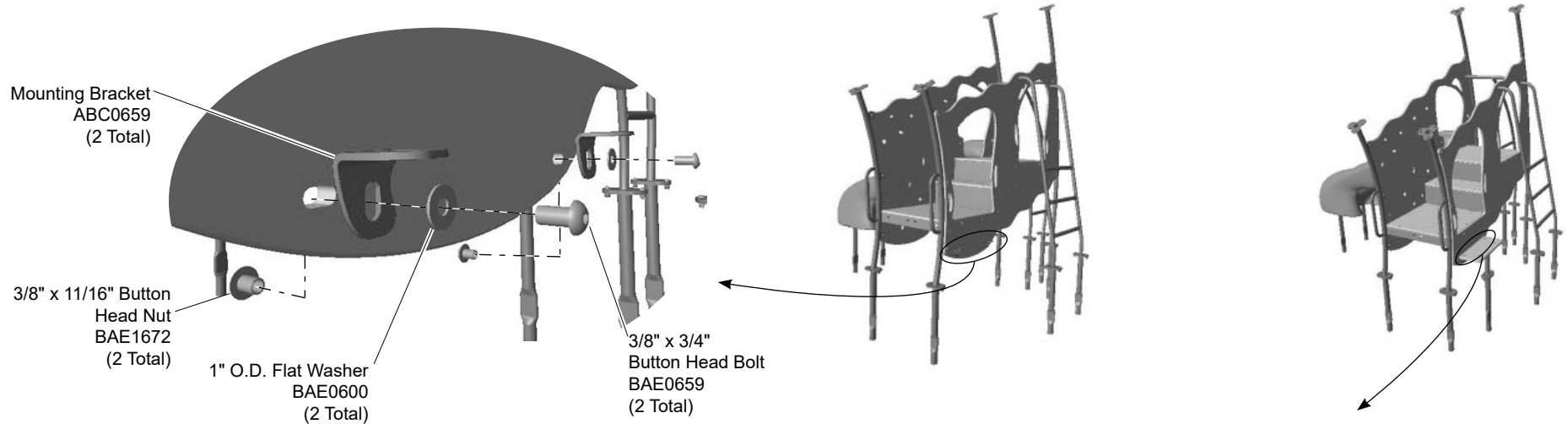

Detail P Step 18



Attach the mounting brackets to the climber panel.

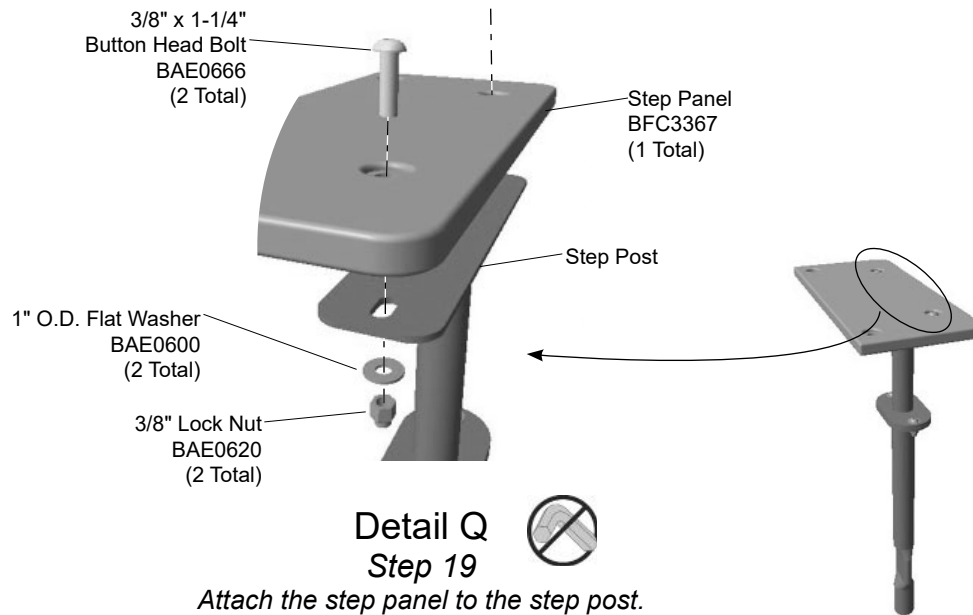

Detail Q Step 19



Attach the step panel to the step post.

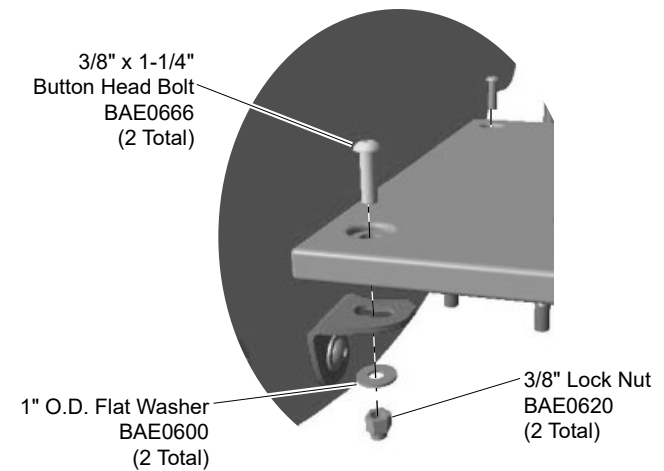

Detail R Step 20



Attach the step post to the climber panel.

Installation Instructions

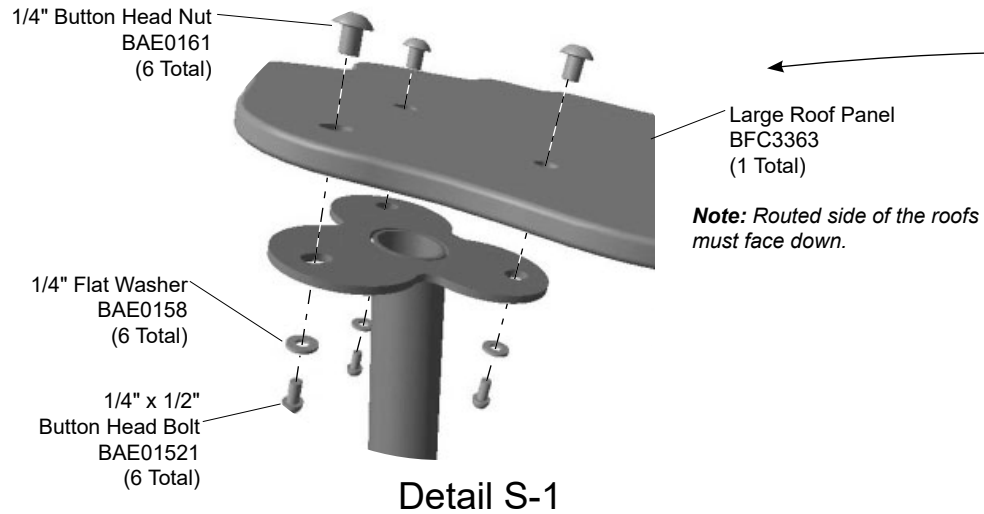

Attach the large roof to the tall support posts.

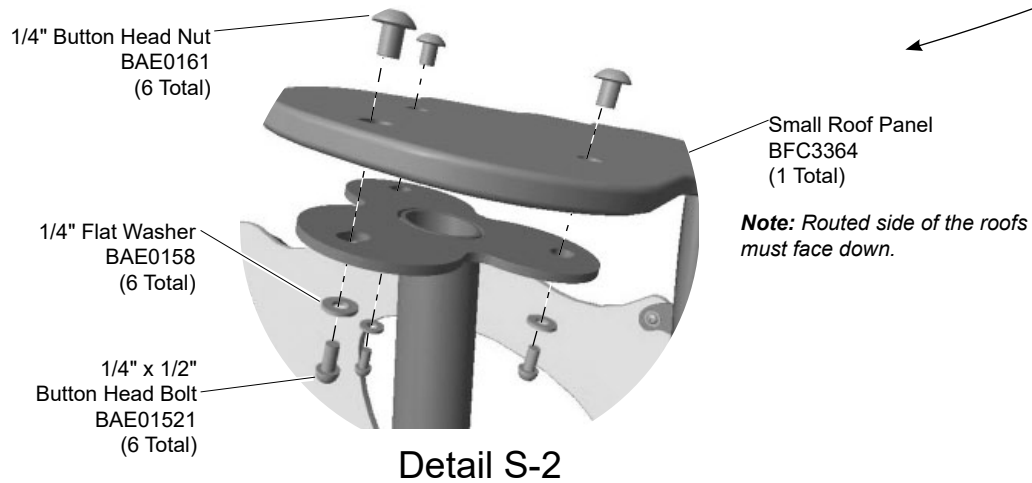
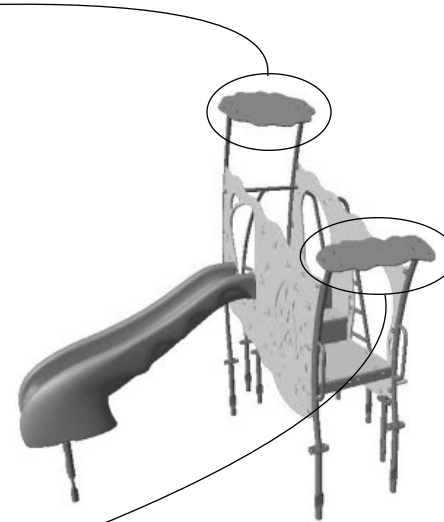

Attach the small roof to the short support posts.

Details S-1 and S-2
Step 21



Attach the roofs to the support posts.

Installation Instructions

Plastic Bolt Cap & Washer (two-piece assembly) BPL0300 (3 Total)
1/4" Thin Series Lock Nut BAE0611 (3 Total)
5/16" O.D. Nylon Coved Washer BAE0202 (3 Total)
Raised side fits into the plastic washer.
1" Diameter Connector AMC0097 (3 Total)
1/4" x 3/4" Button Head Bolt BAE01524 (3 Total)
1/4" Flat Washer BAE0158 (3 Total)
3/8" x 1/2" Button Head Bolt BAE0661 (1 Total)
Slider Stop BFC1222 (1 Total)
3/8" x 11/16" Button Head Nut BAE1672 (1 Total)

Detail T Step 22
Assemble the plastic cap sliders.

Detail U Step 23
Insert into the slots in the slide panel.

Detail V Step 24
Attach the slider stop to the the slide panel.

Detail W Step 26
Install bolt caps to the tie rod / panel connection.

Installation Instructions

Notes Before You Begin: Do not over tighten bolts during assembly, only snug tighten them until assembly is complete

Carefully read and understand these installation instructions before you begin.

Step 1: Before attempting to assemble your equipment, please review all installation information carefully. Should you experience any difficulty during the installation process, please call us at the phone number shown on the last page of these instructions.

Step 2: Separate and identify all components and hardware.

Step 3: Excavate or prepare the footings as shown in the **Footing Details** on pages 4-5 of this document. Use the **Component Footing Detail** for the in-ground model. Reference the **Footing Diagram** provided with the **Elevation Views** for the layout of the footings.

Step 4: (in-ground model only) Attach the anchor legs to the playground posts and climbers. See **Detail A**. Position an anchor leg against the bottom of each post and climber and attach as shown. Fully tighten the connections according to tightening torque specifications.

Torque Specifications:

Bolts and nuts - Snug tighten and then tighten an additional one half turn.

Step 5: Attach the exit support frame / bracket to the straight slide. See **Detail B**. Position the exit support frame or bracket into the bottom of the slide exit and attach as shown. Fully tighten the connections according to tightening torque specifications before putting in the slots.

Torque Specifications:

Bolts and nuts - Snug tighten and then tighten an additional one half turn.

Step 6: Attach the climber panel to a short and tall support post. See **Detail C**. Place the climber panel on the post tabs and attach to the post tabs as shown.

Step 7: Attach the slide panel to a short and tall support post. See **Detail D**. Place the slide panel on the post tabs and attach to the post tabs as shown.

Step 8: Attach the support brackets to the climber panel. See **Detail E**. Position the brackets, oriented as shown in the Bracket Placement Reference, against panel at the locations shown in the references, and attach as shown.

Step 9: Attach the slide panel to the support brackets. See **Detail F**. Stand panel assemblies up and place in, or on, their footings to make the connections. Position the slide panel assembly against of the brackets and attach as shown.

Step 10: Attach the angle brackets to the panels. See **Detail G**. Position the angle brackets against the panels at the locations indicated in the reference and attach as shown. The side with one slot should be facing up.

Step 11: Attach the plastic platforms to the brackets. See **Detail H** and the detail references to the right of the detail. Place each panel, with the side containing the routed out holes facing up, on top of the brackets and attach as shown.

Step 12: Attach the remaining angle bracket to the slide panel. This is the bracket the slide will attach to in the next step. See **Detail J**. Attach the mounting bracket to the panel as shown.

Step 13: Attach the straight slide to the slide panel. See **Details K-1 and K-2**. Position the slide against the slide panel and attach as shown.

Step 14: Attach the tie rod to the slide ladder climber. See **Detail L**. Position the tie rod and casting against the top of the slide ladder climber and attach as shown.

Step 15: Attach the slide ladder climber and end panel to the playground assembly. See **Details M-1 and M-2**. Position the end panel against the end support bracket and attach as shown on the end connections only. Position the climber assembly against the middle of the end panel and attach as shown.

Step 16: Attach the tie rod to the slide and climber panels. See **Detail N**. Attach the tie rod to the panels as shown.

Step 17: Attach the ladder climber to the climber panel. See **Detail O**. Position the top of the climber against the high end of the climber panel and attach as shown.

Step 18: Attach the mounting brackets to the climber panel. See **Detail P**. Position the brackets against the lower end of the climber panel, and with the open side of the bracket facing up, and attach as shown.

Step 19: Attach the step panel to the step post. See **Detail Q**. Position the panel on top of the step post and attach shown to the front holes only in the step.

Installation Instructions

Step 20: Attach the step post to the climber panel. See **Detail R**. Position the step post against the climber panel with the step on the mounting brackets and attach as shown.

Step 21: Attach the roofs to the support posts. See **Details S-1 and S-2**. Place the roofs, with the routed side facing down, on top of their respective posts and attach as shown.

Step 22: Assemble the plastic cap sliders. See **Detail T**. Assemble the plastic cap sliders as shown. Fully tighten the fasteners according to tightening torque specifications.

Step 23: Insert into the slots in the slide panel. See **Detail U**. Insert the sliders into the open slot on the side panel as shown.

Step 24: Attach the slider stop to the slide panel. See **Detail V**. Position the slider stop against the slide panel and attach as shown. Fully tighten the fasteners according to tightening torque specifications.

Final Details.

Step 25: Plumb and level the component. Tighten **all** fasteners. Fully tighten all fasteners according to tightening torque specifications.

Torque Specifications:

Bolts and nuts - Snug tighten and then tighten an additional one half turn.

In-Ground: Block and brace for concrete. Pour concrete after all equipment has been assembled. Allow 72 hours for concrete to completely cure.

Surface Mount: Bolt down all surface mount supports in accordance with specifications provided by your registered structural engineer.

Important Note: Surface mount hardware is not supplied. Customer is responsible for concrete base and for providing surface mount hardware as specified by a registered structural engineer for each specific project application.

Step 26: Install bolt caps to the tie rod / panel connection. See **Detail W**. Insert the bolt caps into the plastic washers at the tie rod / panel connections. Bolt caps will install easier when they are warm.

Step 27: For areas complying with ASTM standard F1487 or the CSA Z-614, apply the age appropriate label to the component at eye level.

Bill of Materials

XX0474 - PLAYTOWN PLAYGROUND

PART NO.	DESCRIPTION	QTY.	PART NO.	DESCRIPTION	QTY.
AAU0724	CASTING - 1.315" DIA ADAPTER	1	BFC3367	SHEET - .75" x 8.00" x 18.00"	1
ABC0659	BRACKET - 2.16" x 2.16" x 2.00"	2	BFC3368	SHEET - 24.00" x 26.00" x .75"	2
ABC0661	BRACKET - 1.00" x 1.50" x 12.00"	4	BPL0231	FUN CENTER STRAIGHT SLIDE	1
ABC0662	BRACKET - 1.50" x 3.00" x 26.00"	2	BPL0300	CAP - 3/8" BOLT	5
ABC0664	BRACKET - .11" x 4.00" x 26.00"	2	ASY0589	LABEL KIT - 18 MTHS - 12 YRS ASTM, CSA, FRENCH	1
ACL0336	CLIMBER - PLAYTOWN SIDE LADDER	1			
ACL0337	CLIMBER - PLAYTOWN LADDER	1			
AFM5490	FAB METAL - 1.315" O.D. x 25.78" w/INSERTS	1			
AFR1043	FRAME - PLAY SIMPLE LEG (ROUND)	9			
AMC0097	CONNECTOR - 1 DIA x .57 w/HOLE	3			
APT5152	POST - 13.00" x 3.00" x 9.22"	1			
APT5153	POST - PLAYGROUND SHORT	2			
APT5154	POST - PLAYGROUND TALL	2			
APT5165	POST - 3.75" x 25.00" x 32.36"	1			
BAE01521	BOLT - 1/4"-20 x 1/2" BUTTON HEAD - S.S.	12			
BAE01524	BOLT - 1/4"-20 x 3/4" BUTTON HEAD - S.S.	3			
BAE0158	WASHER - 1/4" SAE FLAT	15			
BAE0161	NUT - 1/4"-20 x 7/16" BUTTON HEAD	12			
BAE0202	NYLON WASHER - .56" x .12"	3			
BAE0595	WASHER - 3/8" SAE FLAT	2			
BAE0600	WASHER - 1" O.D. FLAT	102			
BAE0611	NUT - 1/4"-20 THIN SERIES HEX LOCK w/o NYLN CP	3			
BAE0620	NUT - 3/8"-16 LOCK w/NYLON CAP	62			
BAE0659	BOLT - 3/8"-16 x 3/4" BUTTON HEAD - S.S.	14			
BAE0661	BOLT - 3/8"-16 x 1/2" BUTTON HEAD - S.S.	1			
BAE0664	BOLT - 3/8"-16 x 1" BUTTON HEAD - S.S.	20			
BAE06645	BOLT - 3/8"-16 x 1-1/2" BUTTON HEAD - S.S.	2			
BAE0666	BOLT - 3/8"-16 x 1-1/4" BUTTON HEAD - S.S.	46			
BAE06673	BOLT - 3/8"-16 x 2" BUTTON HEAD - S.S.	1			
BAE0668	BOLT - 3/8"-16 x 2-1/2" BUTTON HEAD - S.S.	2			
BAE0900	WRENCH - 5/32" SHORT HEX KEY	1			
BAE0902	TOOL - 7/32" SHORT HEX KEY WRENCH	1			
BAE0922	TOOL - TT 45 L WRENCH	2			
BAE1672	NUT - 3/8"-16 x 11/16" BUTTON HEAD	15			
BFC1222	SHEET - .56" x 2.63" x 1.32"	1			
BFC3361	SHEET - .75" x 47.96" x 78.43" CLIMBER	1			
BFC3362	SHEET - .75" x 47.96" x 78.43" SLIDE	1			
BFC3363	SHEET - .50" x 19.65" x 33.75"	1			
BFC3364	SHEET - .50" x 10.16" x 33.25"	1			
BFC3365	SHEET - .50" x 5.00" x 26.00"	1			
BFC3366	SHEET - 10.00" x 26.00" x .75"	1			



Bill of Materials

XX0474S - PLAYTOWN PLAYGROUND SURFACE MOUNT

PART NO.	DESCRIPTION	QTY.	PART NO.	DESCRIPTION	QTY.
AAU0724	CASTING - 1.315" DIA ADAPTER	1	BFC3367	SHEET - .75" x 8.00" x 18.00"	1
ABC0257	BRACKET - .50" x 3.75" x 36.00"	1	BFC3368	SHEET - 24.00" x 26.00" x .75"	2
ABC0659	BRACKET - 2.16" x 2.16" x 2.00"	2	BPL0231	FUN CENTER STRAIGHT SLIDE	1
ABC0661	BRACKET - 1.00" x 1.50" x 12.00"	4	BPL0300	CAP - 3/8" BOLT	5
ABC0662	BRACKET - 1.50" x 3.00" x 26.00"	2	ASY0589	LABEL KIT - 18 MTHS - 12 YRS ASTM, CSA, FRENCH	1
ABC0664	BRACKET - .11" x 4.00" x 26.00"	2			
ACL0336	CLIMBER - PLAYTOWN SIDE LADDER	1			
ACL0337	CLIMBER - PLAYTOWN LADDER	1			
AFM5490	FAB METAL - 1.315" O.D. x 25.78" w/INSERTS	1			
AMC0097	CONNECTOR - 1 DIA x .57 w/HOLE	3			
APT5152	POST - 13.00" x 3.00" x 9.22"	1			
APT5153	POST - PLAYGROUND SHORT	2			
APT5154	POST - PLAYGROUND TALL	2			
APT5165	POST - 3.75" x 25.00" x 32.36"	1			
BAE01521	BOLT - 1/4"-20 x 1/2" BUTTON HEAD - S.S.	12			
BAE01524	BOLT - 1/4"-20 x 3/4" BUTTON HEAD - S.S.	3			
BAE0158	WASHER - 1/4" SAE FLAT	15			
BAE0161	NUT - 1/4"-20 x 7/16" BUTTON HEAD	12			
BAE0202	NYLON WASHER - .56" x .12"	3			
BAE0595	WASHER - 3/8" SAE FLAT	2			
BAE0600	WASHER - 1" O.D. FLAT	66			
BAE0611	NUT - 1/4"-20 THIN SERIES HEX LOCK w/o NYLN CP	3			
BAE0620	NUT - 3/8"-16 LOCK w/NYLON CAP	44			
BAE0659	BOLT - 3/8"-16 x 3/4" BUTTON HEAD - S.S.	14			
BAE0661	BOLT - 3/8"-16 x 1/2" BUTTON HEAD - S.S.	1			
BAE0664	BOLT - 3/8"-16 x 1" BUTTON HEAD - S.S.	2			
BAE06645	BOLT - 3/8"-16 x 1-1/2" BUTTON HEAD - S.S.	2			
BAE0666	BOLT - 3/8"-16 x 1-1/4" BUTTON HEAD - S.S.	46			
BAE06673	BOLT - 3/8"-16 x 2" BUTTON HEAD - S.S.	1			
BAE0668	BOLT - 3/8"-16 x 2-1/2" BUTTON HEAD - S.S.	2			
BAE0900	WRENCH - 5/32" SHORT HEX KEY	1			
BAE0902	TOOL - 7/32" SHORT HEX KEY WRENCH	1			
BAE0922	TOOL - TT 45 L WRENCH	2			
BAE1672	NUT - 3/8"-16 x 11/16" BUTTON HEAD	15			
BFC1222	SHEET - .56" x 2.63" x 1.32"	1			
BFC3361	SHEET - .75" x 47.96" x 78.43" CLIMBER	1			
BFC3362	SHEET - .75" x 47.96" x 78.43" SLIDE	1			
BFC3363	SHEET - .50" x 19.65" x 33.75"	1			
BFC3364	SHEET - .50" x 10.16" x 33.25"	1			
BFC3365	SHEET - .50" x 5.00" x 26.00"	1			
BFC3366	SHEET - 10.00" x 26.00" x .75"	1			



Fasteners

- Inspect for loose fasteners. Tightening torque specifications are: Bolts and Nuts: Snug tighten and tighten an additional one-half turn.
- Inspect for missing, worn or broken fasteners. If any missing, worn or broken fasteners are found, refer to the installation instructions for proper replacement fastener. If any damage is detected, barricade equipment to prevent use until repair is completed. Contact your sales representative immediately for a replacement part.

Plastic Parts

- Inspect all plastic surfaces for sharp points, cracks or jagged edges. If any damage is detected and is determined to be unsafe, barricade equipment to prevent use until repair is completed. Minor burrs or sharp edges may be removed by using a sharp utility knife or block plane to remove sharp burr.

Welds

- Inspect all welded joints. If any broken welds are detected, barricade equipment to prevent use until repair is completed. Contact your sales representative immediately for a replacement part.

Finish

- Inspect metal parts for finish damage. To repair painted surfaces, sand damaged area with sandpaper and wipe clean. Mask area and paint with primer and allow to dry. Paint primed area with color-matching paint and allow to dry. Recoat area with color-matching paint if required. Drying time is approximately 8 hours between coats.

Footings

- Inspect component to be solid in footing and secure. If any damage is detected, barricade equipment to prevent use until repair is completed.

Surfacing

- Raking loose-fill surfacing material back into dug out and displaced areas is necessary at frequent intervals to maintain the impact absorption qualities.
- Loose-fill materials must be replenished when the surface level drops below the minimum level to maintain proper depth in accordance with your equipment's critical fall height.
- Eliminate areas of standing water by improving site drainage.
- Contact manufacturer of unitary surfacing material for specific instructions and product to use for cleaning spots and stains.
- Contact manufacturer of unitary surfacing material if rips, tears or missing material is noticed. Follow the manufacturer instructions regarding the appropriate actions necessary for the repair.

Labels

- Inspect all applied labels to ensure labels are secure, not faded or damaged. Contact your local representative if replacement labels are needed.

Replacement Parts

- Refer to your installation instructions to obtain replacement part number.
- Contact your sales representative or call Playworld Systems' Customer Service for a replacement part.

Equipment Maintenance

Playworld Systems®
Models XX0474 and XX0474S
PlayTown Playground
In-Ground and Surface Mount

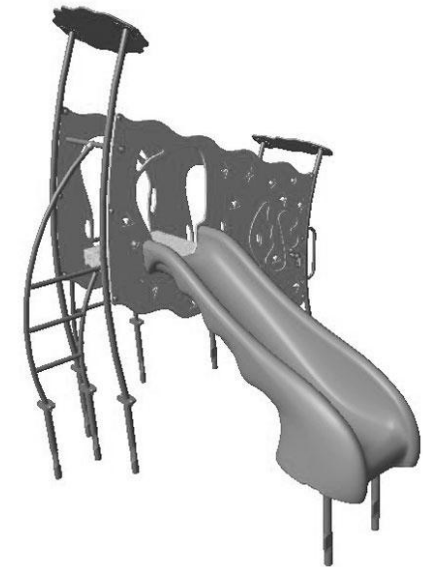

Inspection Form

Preventive Maintenance

... for Safety's Sake!

- Be sure that you are using a copy of this Inspection Form and not your original.
- Use the Inspection Codes listed below and record condition of equipment at time of examination on the Inspection Checklist.
- Document any item from the Inspection Checklist that will require maintenance along with any corrective action on the Maintenance Schedule.
- Be sure to include appropriate dates and signatures on each section to properly document maintenance procedure.

INSPECTION CHECKLIST

	Frequency	Inspection Code	Date	Date Repairs Completed
Inspect plastic parts for damage.	Medium			
Inspect for loose, missing, worn, or broken fasteners.	High			
Inspect metal parts for structural and finish damage.	Medium			
Inspect surfacing to insure proper depth and distribution.	High			
Inspect footing to insure support is secure and footing is not damaged.	Low			

Inspection Codes P = Pass F = Fail NA = Not Applicable
--

Inspector: Name (Please Print) _____ Signature: _____ Date: ___ / ___ / ___

MAINTENANCE SCHEDULE

Item in Question	Description of Problem	Corrective Action	Date

Repairer: Name (Please Print) _____ Signature: _____ Date: ___ / ___ / ___



Important ! Please Read Completely Before Beginning Installation. According to a report published by the U. S. Consumer Product Safety Commission (C.P.S.C.) 72% of all playground injuries result from accidental falls. With this in mind, this equipment is designed to fill the need for safe yet challenging play. In conjunction with design efforts to reduce the possibilities of injuries, this equipment **must** be installed "Step by Step" per our installation instructions. As a new owner you are responsible for the correct installation, safe use, and maintenance of your equipment.

Installation Guidelines

- Identify all parts and thoroughly read the assembly instructions before beginning construction.
- Refer to your playground equipment plan and footing diagram to assure the equipment purchased will fit into your selected site area. The use and no-encroachment zones around the play equipment shall be obstacle-free areas designated for unrestricted circulation.
- If the stationary play equipment contains a slide (or slides), the use zones of the slide (or slides) may not be overlapped by the use zones of adjacent play equipment.
- **ASTM compliance:** The overall use zone measurements for stationary play equipment should extend a minimum of 72 inches (1829 mm) from its perimeter; dimensions and configuration of the use zone are dependent upon the types of included play equipment. The use zone of stationary play equipment may be overlapped by the use zone of adjacent stationary play equipment if the adjacent designated play surfaces are no greater than 30 inches (762 mm) above the protective surfacing level. They should be a minimum of 72 inches (1829 mm) apart. If the adjacent designated play surfaces are greater than 30 inches (762 mm) above the protective surfacing level, the pieces of equipment should be a minimum of 108 inches (2743 mm) apart.

The use zone in front of the slide exit shall be a minimum of 72 inches (1829 mm) and shall not exceed 96 inches (2438 mm). The use zone shall be measured from the end of the slide and equal the vertical measurement as measured from the highest point of the sliding surface to the protective surfacing at the slide exit.

Example: If the highest point of the sliding surface is 73.5 inches (1867 mm), the use zone in front of the slide exit should measure 73.5 inches (1867 mm).

- **CSA compliance:** The overall use zone measurements for stationary play equipment should extend a minimum of 1800 mm from its perimeter; dimensions and configuration of the use zone are dependent upon the types of included play equipment. The use zone of stationary play equipment may be overlapped by the use zone of adjacent stationary play equipment if the adjacent designated play surfaces are no greater than 700 mm above the protective surfacing level. They should be a minimum of 1800 mm apart.

The use zone in front of the slide exit shall be a minimum of 1800 mm) and shall not exceed 2400 mm. The use zone shall be measured from the end of the slide and equal the vertical measurement as measured from the highest point of the sliding surface to the protective surfacing at the slide exit.

A no-encroachment zone is also required for the exit of a slide higher than 48" (1219 mm). In addition to the use zone measurement at the runout of the slide, the no-encroachment zone will extend an additional 1800 mm and may not be overlapped by the use or no-encroachment zones of adjacent play equipment.

- **EN compliance:** The overall use zone measurements for stationary play equipment are dependent upon the fall height of the equipment. For a fall height exceeding 1500 mm a formula is applied to determine the use zone (impact zone) of the equipment. There is a minimum of 1500 mm from its perimeter; dimensions and configuration of the use zone are dependent upon the types of included play equipment. Refer to the Use Zone diagram or master structure drawing.

The use zone at the end of the slide runout will be at least 2000 mm for Type 1 slides. (All Playworld Systems slides are Type 1)

- Site layout is a critical part of the overall installation. Footings must be measured and marked accurately according to the footing diagram. A level and clear installation site is ideal.
- Good drainage around the structure and its supports is important. Inquire with local contractors for appropriate recommendations.
- After laying out all footings and before digging holes, be sure to inquire about underground utilities that may exist.

Guidelines

- Do not leave the job site unattended without making sure that all fastening hardware on all components are tightened according to tightening torque specifications listed on every installation guide. We also recommend roping off construction area and covering all holes that do not contain a piece of equipment with plywood or other suitable material.
- Excavate holes as shown in the footing detail. If a level and clear site cannot be obtained, adjust the depth of footing to maintain a level footing base. If soil conditions are loose or unstable, a larger diameter footing may be required. Inquire with local contractors for appropriate recommendations. Be sure concrete that might have splashed onto the unit is washed off before it dries. Allow concrete to harden 72 hours before allowing your structure to be used. **Assemble the entire structure before pouring concrete unless specifically instructed to do so in the installation instructions.**
- Insure that Age Appropriate and Hard Surface Warning/Playworld Systems identification labels are properly affixed to the play equipment. Labels are to be plainly visible according to current playground equipment guidelines.
- **IMPORTANT!** Because accidental falls around your playground equipment can occur, Playworld Systems recommends that the area under and around the structure be covered with a resilient material such as sand, bark mulch, or wood chips. If loose fill surfacing materials are used, Playworld Systems recommends a depth of 12 in. (305 mm). An approved rubber safety matting can also be used. **Many protective surfacing materials can become compacted due to weather and use, which reduces their shock absorbency. It is strongly recommended that the surfacing be checked weekly and material added or replaced as necessary. Hard surfaces, such as asphalt, concrete and packed earth are not acceptable for use under playground equipment.**
- The entire area, under and around the playground equipment, must be covered with protective surfacing material. The impact attenuation of the protective surfacing under and around playground equipment should be rated to have a critical height value of at least the height of the highest accessible part of the equipment. The critical height for surfacing is to be rated in accordance with A.S.T.M. standard, designated F1292, A Standard Specification for Impact Attenuation of Surface Systems Under and Around Playground Equipment. Critical fall heights for Europe and Canadian compliance shall be listed on the elevation page or master structure drawing if they differ from the ASTM standard. Contact the manufacturer of unitary surfacing materials (rubber matting) for the critical height rating for their products.

Tools Required: Playworld Systems supplies a service kit that contains commonly used hex key wrenches required to assemble your equipment. You may also need: shovel, digging iron, post hole digger, steel rake, wheelbarrow, garden hoe, water hose, tape measure, level, alignment tool, 3/8" ratchet with 9/16" socket, and 9/16" combination wrench.

Maintenance

- Inadequate maintenance of equipment has resulted in injuries on the playground. Because the safety of playground equipment and its stability depends on good inspection and maintenance, **a comprehensive maintenance program must be developed for each playground and strictly followed.** All equipment must be inspected frequently for any potential hazards. Special attention must be given to moving parts and other components that can be expected to wear. Inspections must to be carried out in a systematic manner by trained personnel. Any damaged or worn parts, or any other hazards identified during inspections must be repaired or replaced immediately. Complete documentation of all maintenance inspections and repairs must be retained.

Supervision Guidelines

- Playworld Systems strongly recommends close supervision of the children as they play as well as intensive classroom and home instruction about safe behavior on playground equipment.
- Playground supervisors should be aware that not all playground equipment is appropriate for all children who may use the playground. Signs should be posted near the equipment indicating the recommended age of the users. Supervisors should direct children to equipment appropriate for their age.
- It is important that playground supervisors recognize that preschool-age children require more attentive supervision on playgrounds than older children.
- Do not permit the use of wet playground equipment. Wet equipment will inhibit necessary traction and gripping capabilities. Slips or falls could occur.
- Do not permit too many children on the same piece of equipment at the same time. It is suggested that children take turns.
- Constantly observe play patterns to discover possible hazardous play and suggest changes in equipment use or play patterns.

Footings Details (in ground)

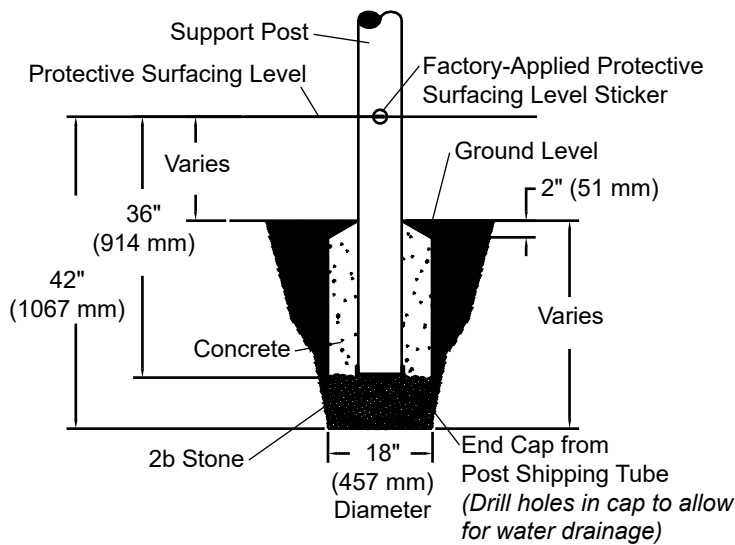

Support Post Footing Detail (ASTM/CSA)

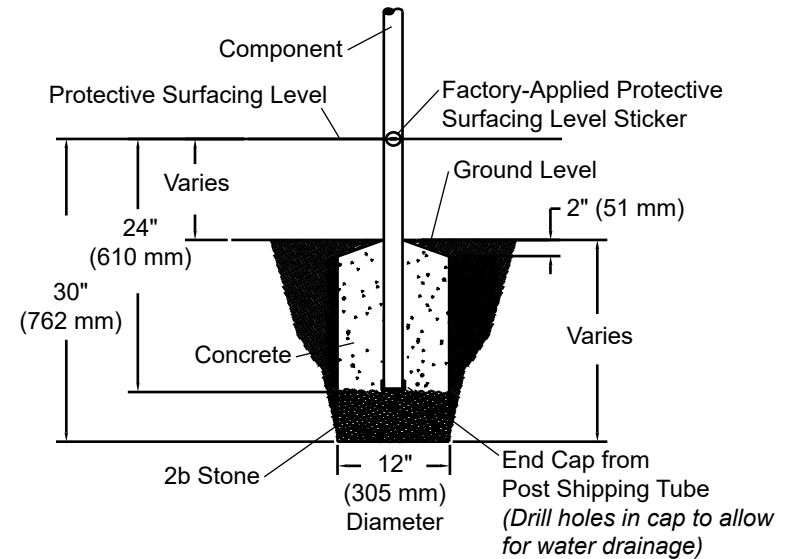

Component Footing Detail (ASTM/CSA)

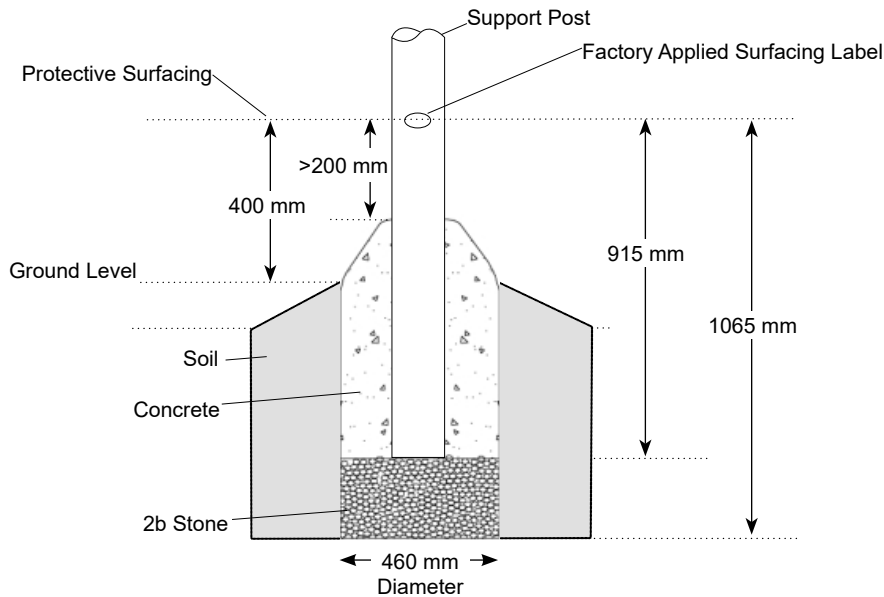

Footing Detail Support Post (EN)

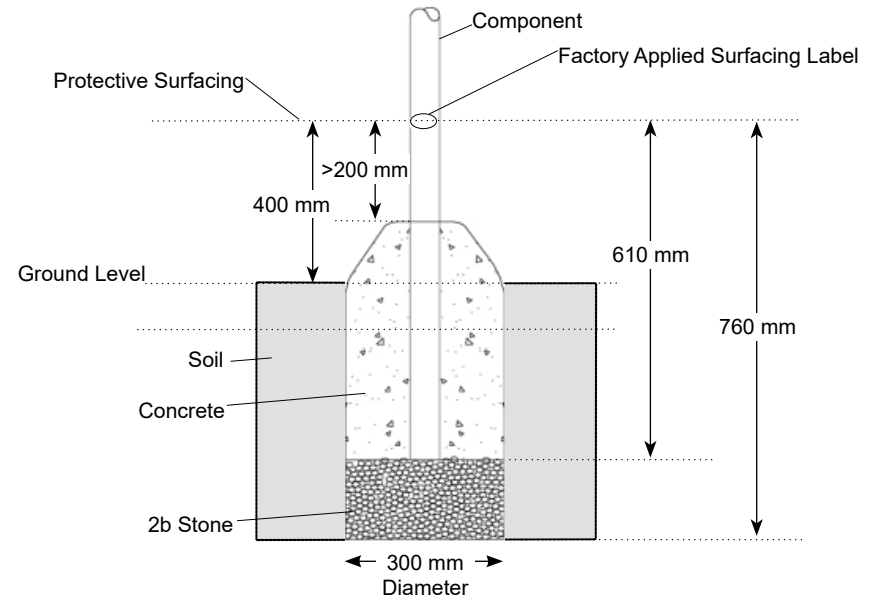

Footing Detail Component Post (EN)

Footings Notes & Details

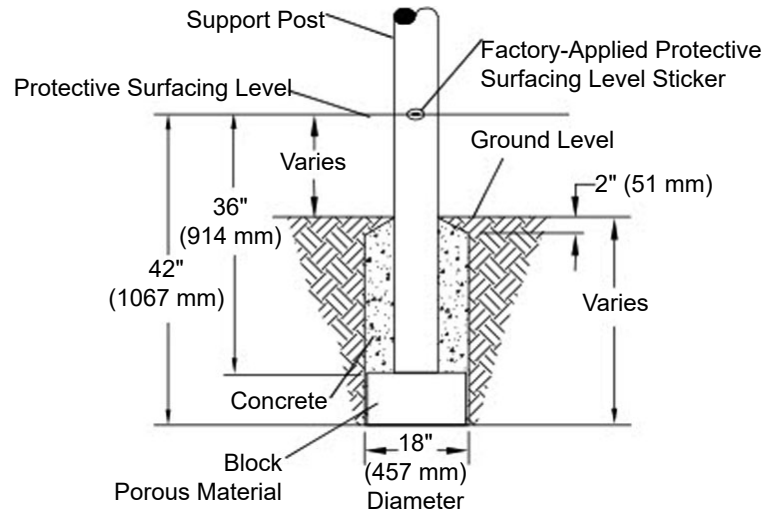

Support Post Footing Detail (ASTM/CSA)
Block Option

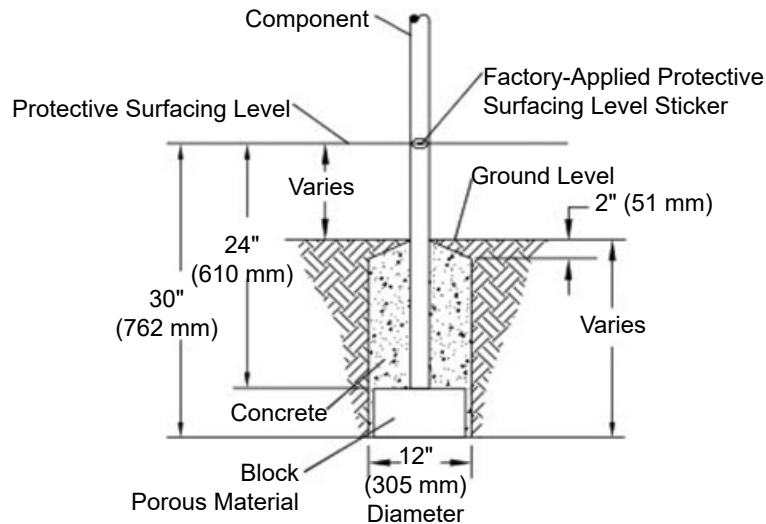

Component Footing Detail (ASTM/CSA)
Block Option

FOOTING NOTES (IN GROUND)

- Support post footing depth equals 42 in. (1067 mm) minus the depth of the protective surfacing material. The posts are designed to have 24" (610 mm) in concrete.
Example: If 12 in. (305 mm) of wood mulch is used for surfacing, the footing depth would be 30 in. (762 mm).
- Component footing depth equals 30 in. (762 mm) minus the depth of the protective surfacing material. The posts are designed to have 12" (305 mm) in concrete.
Example: If 12 in. (305 mm) of wood mulch is used for surfacing, the footing depth would be 18 in. (457 mm).
- Most support posts and component support legs will have either a factory-applied sticker with a line, or factory-applied mark designating the level of protective surfacing on a clear and level installation site. The footing depth measurements are based on this line/mark.
- If the play equipment is installed on uneven terrain, maintain support post mark for the protective surfacing level at the lowest grade. Adjust other footings accordingly. Support posts and all attaching decks and play components must be plumb and level.
- Do not encase the bottom of the support post in concrete. Place the post directly on packed stone or other porous material.
- The footings shown on Playworld Systems' documentation are recommendations based on historical performance in average soil conditions. Footing dimensions may be modified by the owner based on actual soil conditions.
For example:
 - If local soil is loose or unstable, a larger footing may be required.
 - If local soil is considered stable, such as bedrock, clay or hard packed earth, a smaller footing may be used. Before changing footing dimensions, we strongly recommend that the footings be reviewed and approved by a registered engineer.
- The base of the footing must be below the frost line.
- Assemble the entire structure before pouring concrete unless specifically instructed to do so in the installation instructions.

Footing Notes & Details

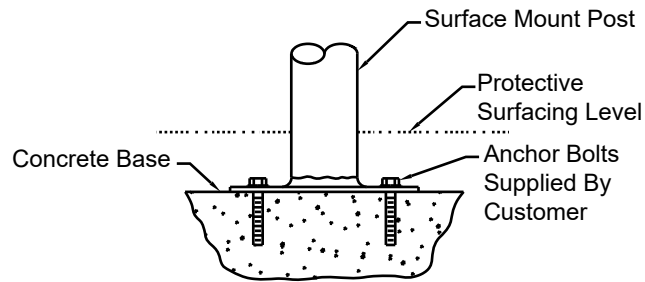

Surface Mount Footing Detail

FOOTING NOTES (SURFACE MOUNT)

- Most support posts and component support legs will have either a factory-applied sticker with line, or factory-applied mark designating protective surfacing level on a clear and level installation site.
- If the play equipment is installed on uneven terrain, maintain support post mark for the protective surfacing level at the lowest grade. Adjust other footings accordingly. Support posts and all attaching decks and play components must be plumb and level.
- The footing size may vary due to local soil and weather conditions.
- Base of footing must be below frost line.

Surface mount hardware is not supplied. Customer is responsible for concrete base and providing surface mount hardware as specified by a registered structural engineer for each specific project application.