

# CORNELL

## Rolling Counter Doors

### Model ESC10

#### Practical Design Applications

- Service Window Openings
- Cafeterias
- Stadiums
- Arenas
- Hospitality/Public Space
- Educational Facilities
- Healthcare Facilities

#### Benefits

- Q/S Program - Cornell can manufacture and ship most standard counter doors in one to two weeks.
- Size Flexibility - each unit is built to exact opening size requirements.
- Compact Storage - curtain stores in an overhead coil that is totally supported by the side guides.
- Low Life Cycle Cost - rugged construction and commercial quality materials assure long life.
- Maintenance - little to none.
- Repairs - job records are retained and parts are readily available.

#### Available Options

- Cylinder or slide bolt locking
- Sill angles
- Fixed or removable mullions
- Special corner mullions
- 16 gauge extruded aluminum slat
- Bottom bar sensing edge for motorized units
- Operator covers for exterior mounted units or exposed operators below 8'-0" high



## Specialty Counter Doors



#### Counter Doors with Frame and Countertop

##### Model ESC20

Integral frames are assembled and welded with 16 ga. stainless or steel material, countertops are 14 ga. stainless standard, with plastic

laminates optional. Stainless material is 300 series #4 finish, steel frames are powder coated. These units are fully assembled and can be built into new openings or slip into existing openings.



#### ScreenGard™

22 gauge galvanized steel perforated counter door curtain slats provide full security while

offering airflow and visual access. Ideal applications are public space corridors, for use in food preparation areas and for storefront protection.



#### Graphics Door

Durable, full color images applied to door curtains and hoods. Now, any of these surfaces can be utilized as an opportunity to advertise, create

sponsorship opportunities, educate, inform or add aesthetic interest. Design possibilities are only limited by the imagination.

# Counter Door Components



## Brackets

Minimum 16 gauge steel plates that bolt to guide assembly and support the counter balance shaft and curtain.

**Standard Material & Finish:** steel, with SpectraShield® powder coating 30-7192 gray

## Counter-balance Shaft

3" minimum diameter outer shaft and 5/8" minimum inner shaft. This assembly supports the curtain and contains counter-balance torsion springs for assisting operation.

**Standard Material:** steel



## Hood

Protective sheet metal enclosure for the curtain that provides weather resistance at the head of the counter door and keeps the brackets rigid.

**Standard Material and Finish:** clear anodized aluminum or galvanized steel with exclusive GalvaNex™ finish in light gray or stainless steel with #4 finish



## Guides

Side rail assemblies that bolt to the wall and support the entire weight of the counter door unit.

**Standard Material & Finish:** two piece clear anodized extruded aluminum sections with polypropylene pile runners

**Optional Materials:** stainless steel or galvanized steel

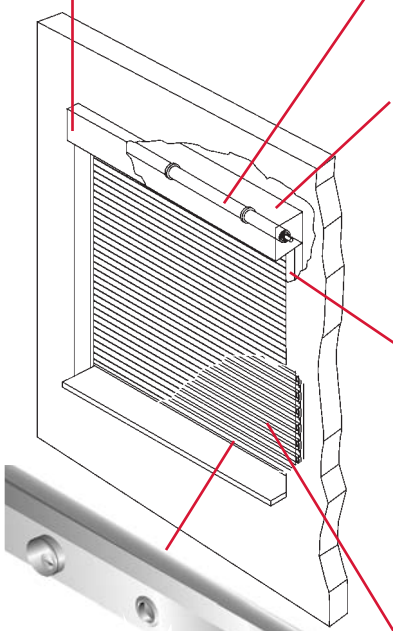

## Bottom Bar

Reinforcing member attached to the bottom of the curtain. Equipped with vinyl astragal/weather-seal to cushion the contact point on the counter. Locking mechanisms available.

**Standard Material & Finish:** clear anodized extruded aluminum for aluminum and galvanized curtains or stainless steel #4 finish for stainless steel curtains.

**Optional Material:** galvanized steel



## Curtain

Interlocking roll formed flat-faced 1-1/2" high slats with endlocks riveted to ends of alternate slats to maintain curtain alignment and prevent wear.

**Standard Material & Finish:** .040" thick clear anodized aluminum or 22 gauge galvanized steel with exclusive GalvaNex™ finish in light gray or 22 gauge stainless steel with #4 finish

## Operation

Push-up operation shown. Hand crank and motors are available. Counter doors operate by rotating the shaft gear end. The opposite end of shaft applies spring tension and is equipped with a spring adjusting wheel.

## Mounting & Clearances

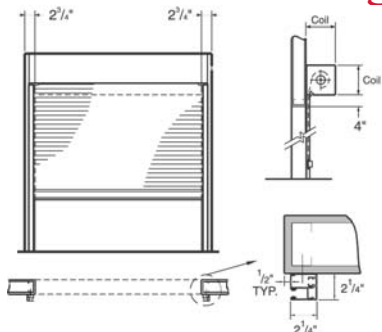

### Face of Wall

Maintains clearance of full opening, minimal exposed components.

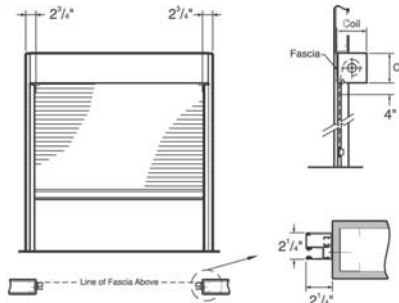

### Between Jambs

Mounts within the opening, fascia (front hood closure piece) required.

Counter doors are built to order to fit specific dimensions up to 21' wide, 10' high or a maximum of 120 square feet.

## Special Applications

- Roll Top Enclosures - for applications that require units to fully or partially cover horizontal openings with the use of curved tracks. Curtains can either coil or store horizontally out of the opening.
- Fixed Guide Mullions - are provided to use multiple units side by side on wide openings using minimal track space.
- Removable Guide Mullions - used for wide openings that require full access on a limited basis.
- Corner Mullions - allow guides from two units to be mounted at 90° on a common tube utilizing an over/under coil set up.
- Machine Guards - ScreenGard™ or solid curtain counter door units may be mounted on machine frame assemblies to provide safety and easy access to machine components.
- Dual Height Countertop Units - special counter door designs can accommodate openings with two different counter heights.
- Countertops - 14 gauge stainless steel countertops are available up to 12' wide, 20" deep. Plastic laminate countertops are available up to 16' wide, 36" deep, in a range of standard laminates.

## Optional Finishes

- Aluminum with medium, dark or black anodized finish
- Powder coat finish in selected color
- Zinc Rich Gray corrosion resistant powder coating
- Hot-dip galvanizing on steel components

## SpectraShield® Powder Coat Finish

Cornell's SpectraShield® Powder Coat Finish adds durability and aesthetic value to our products in a choice of over 200 colors. Surface preparation and the coating process produces a smooth, long lasting finish at controlled costs.



# CORNELL

SAFE AND SECURE

An ISO 9001:2000 Registered Company



239-768-3667  
239-643-3667  
800-375-3667

www.ActionDoor.com