

Project: _____

Item: _____

Quantity: _____

Date: _____

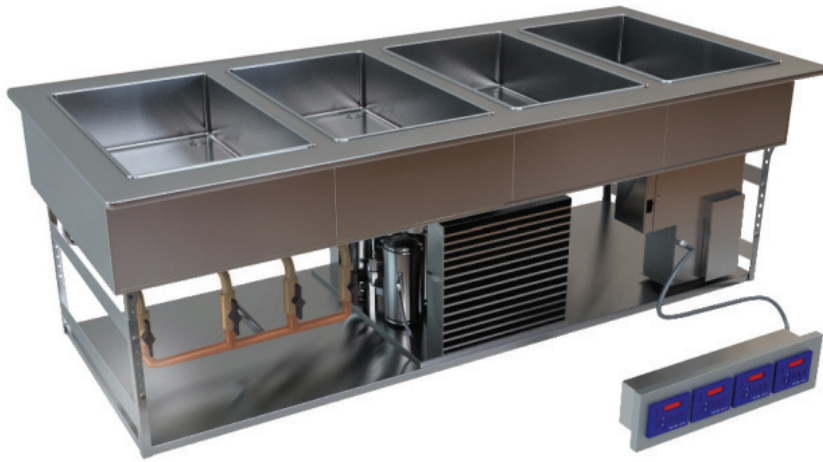

Drop-in Models Pans

- | | |
|------------------------------------|---|
| <input type="checkbox"/> DI-QSHP-1 | 1 |
| <input type="checkbox"/> DI-QSHP-2 | 2 |
| <input type="checkbox"/> DI-QSHP-3 | 3 |
| <input type="checkbox"/> DI-QSHP-4 | 4 |

DI-QSHP-4



- Switch from hot to cold in a matter of minutes!
- Individual well flexibility
- Fully insulated, for use in any counter
- Fast, easy installation
- Labor saving easy to clean design
- Hot well wet or dry operation

Standard Features

- ✓ Individual solid state digital controls
- ✓ Full sealing gasket
- ✓ 500 watts heat source(at 208V)
- ✓ Single power source
- ✓ Manifold drains

Optional Features (specify)

- Hugged edge (H)
- Slim line configuration
- Other voltage, phase, cycle (specify_____)

Number of Pans

- 1 Pan
- 2 Pan
- 3 Pan
- 4 Pan

Voltage

- 120V
- 120/208V
- 120/2408V

90° 1/2" Turn Down

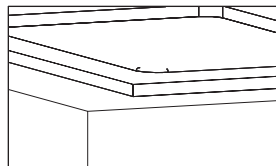

5° Hugged Edge

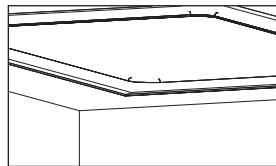

Signature Required for Approval _____

REV 4/14/20 - Printed in the U.S.A.



LTI, Inc.
1947 Bill Casey Parkway (888) 584-2722
Jonesboro, GA 30236 lowtempind.com

Approvals: _____

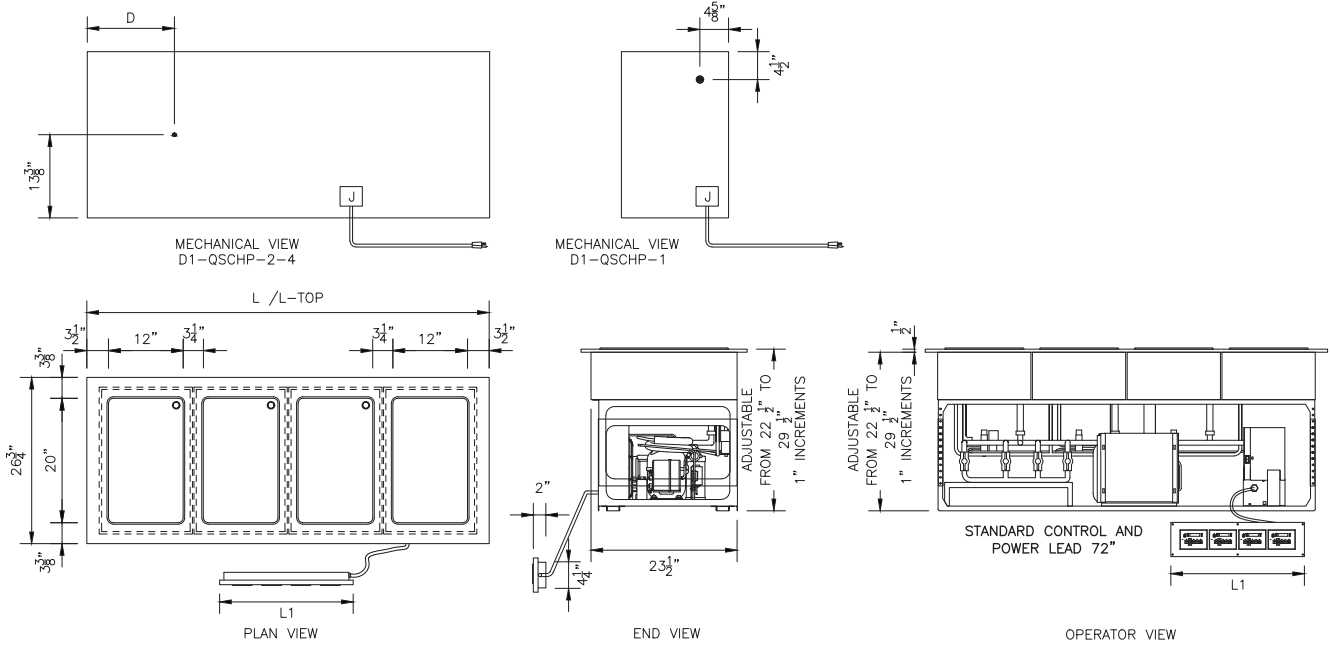

Model #	L - Top	L - Frame	Counter Cut-Out	Control Cut-Out - L1	DRAIN D1	120V/1		120/208V/1		120/240V/1	
						Amps	Plug	Amps	Plug	Amps	Plug
DI-QSCHP-1	17 1/4"	15"	15 3/8" x 24"	6 1/4" x 4 1/4"	N/A	7.2	5-15P	7.2	14-20P	7.2	14-20P
DI-QSCHP-2	34 1/4"	30 1/4"	30 5/8" x 24"	11" x 4 1/4"	4 3/4"	12.7	5-20P	9.6	14-20P	10.0	14-20P
DI-QSCHP-3	49 1/2"	45 1/2"	45 7/8" x 24"	15 3/4" x 4 1/4"	10 1/2"	18.2	5-30P	12.0	14-20P	12.7	14-20P
DI-QSCHP-4	64 3/4"	60 3/4"	61 1/8" x 24"	20 1/2" x 4 1/4"	14"	23.7	5-30P	14.4	14-20P	15.5	14-20P

General Specifications

Top perimeter frame to be constructed of 14 gauge stainless steel, welded, ground and polished with a thermal break provided between the top and refrigerated interior. Interior pan to be 18 gauge stainless steel, fully welded, ground and polished with a 3/4" open drain. To be fully insulated with 1 1/2" to 2" urethane insulation. The exterior jacket to be constructed of heavy gauge stainless steel.

Refrigeration system to be 1/3 hermetically sealed compressor operating on R-507 (HFC) refrigerant, and will include controls. New energy efficient hot food wells use digitally controlled, 500 watt heat source. All switches and controls are fully accessible and are provided with cord and plug. Lower frame is adjustable; overall height from 22 1/2" to 29 1/2".

Units to be UL listed and shall bear the UL classified EPH label for sanitation meeting all NSF4 and NSF7 requirements.

Note: To ensure proper operation, adequate airflow must be provided.

Approval/Submittal (signature required)

Adherence to LTI installation instructions is required. Failure to do so may void the warranty.

Signature _____

Date _____

We reserve the right to change specifications and product design without notice. Such revisions do not entitle the buyer to corresponding changes, improvements, additions or replacement for previously purchased equipment.

All equipment to be built in accordance with the Underwriters Laboratories, Inc. and the National Sanitation Foundation, Inc. standards and shall bear the Underwriters Laboratories, Inc. listing label for safety and the Underwriters Laboratories classification label for sanitation.

Patent 8,307,761