

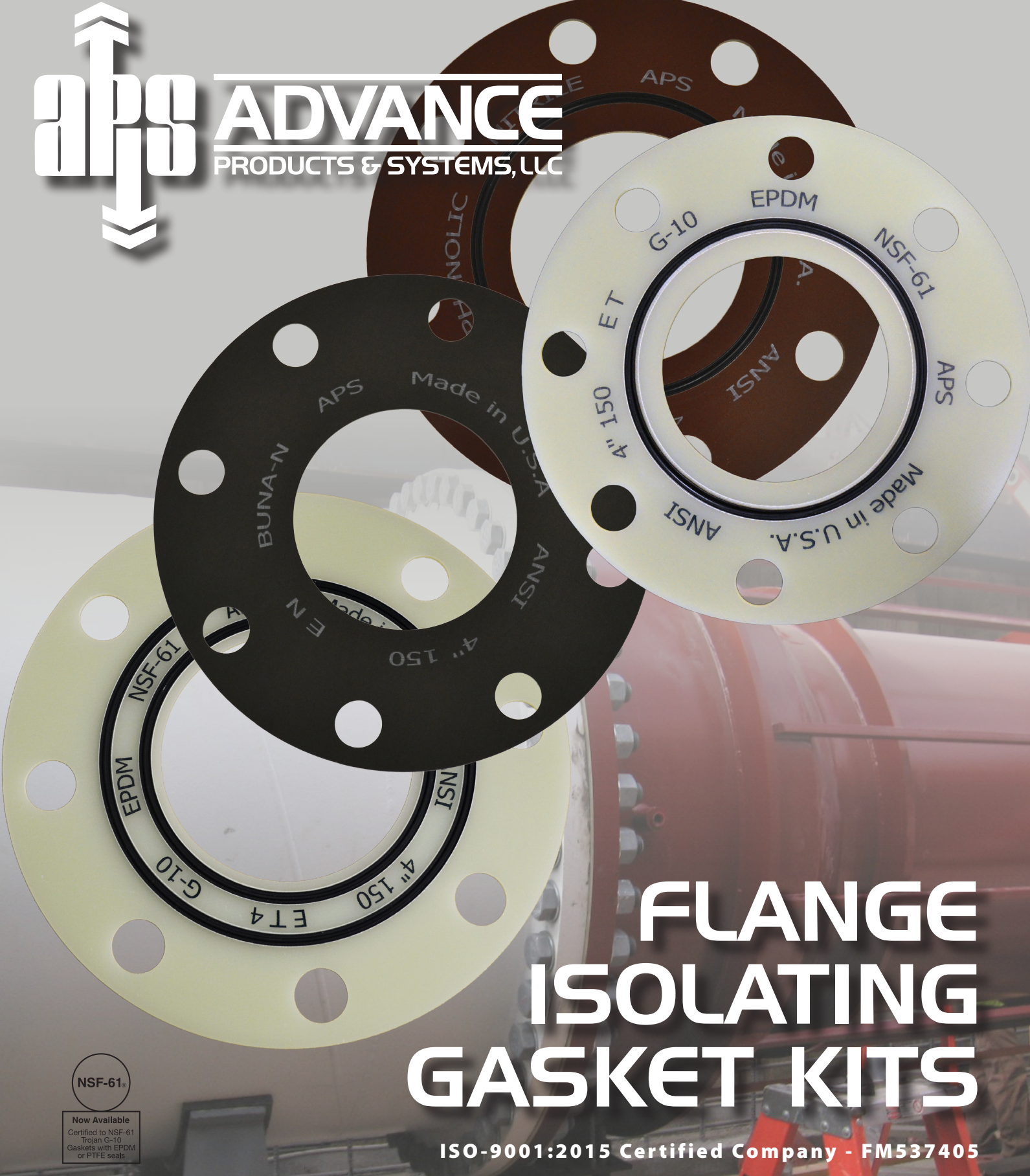

**ADVANCE**  
PRODUCTS & SYSTEMS, LLC



# FLANGE ISOLATING GASKET KITS

ISO-9001:2015 Certified Company - FM537405

NSF-61®

Now Available  
Certified to NSF-61  
Trojan G-10  
Gaskets with EPDM  
or PTFE seals



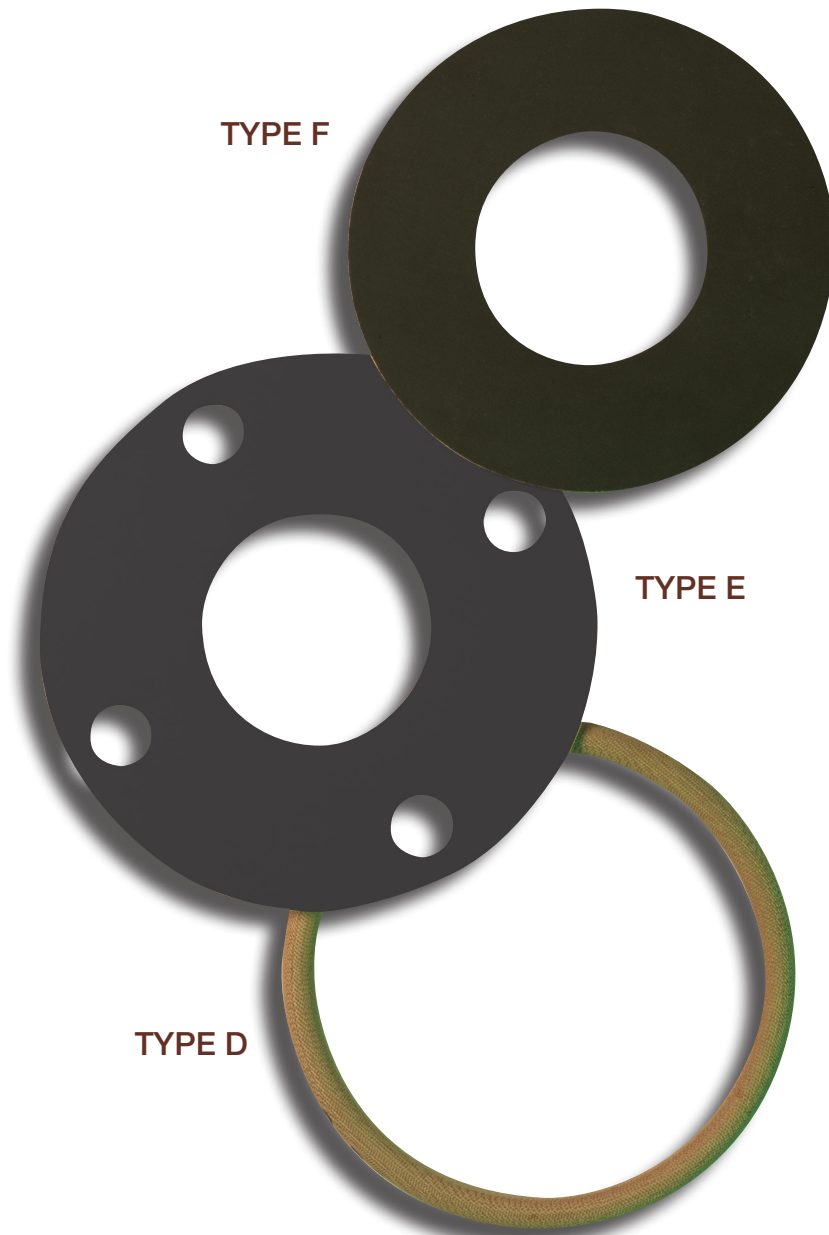

## TYPE F

Type F gaskets are made to fit the raised face portion of the flange only. As there are no bolt holes in the F gasket, the inside diameter of the bolt hole circle is slightly smaller than the outside diameter of the gasket, assuring an exact, automatic positioning of the gasket. Type F gaskets are available in the same materials as the type E gasket. Standard thickness of 1/8".

## TYPE E

Type E is a full-faced gasket with the same outside diameter as the flange and precision cut bolt holes. This design facilitates proper alignment of the gasket during installation and prevents foreign material from shorting the flange isolation. Type E gaskets are available in plain-faced or Nitrile® faced phenolic, as well as a variety of high temperature materials. Standard thickness of 1/8".

## TYPE D

Type D gaskets are specifically designed to fit into the ring groove of ring-type-joint flanges. They are manufactured of medium weave, fabric-reinforced phenolic material and are sized to ANSI and API specifications. Type D gaskets are available in basic oval as well as octagonal shape. Also available are BX gaskets with pressure ratings to 15,000 PSI.

Made to API specifications.

Advance Flange Isolation Gasket Kits are manufactured according to ANSI B16.5 specifications up to 24". Above 24", please provide the specifications of your flange using our convenient worksheet. Technical assistance is available upon request.

**TYPES OF RETAINERS**

RETAINER	WATER ABSORPTION	TENSILE STRENGTH	COMPRESSION STRENGTH	DIELECTRIC VALUES	MAX CONTINUOUS OPERATING TEMPERATURE		FLEXURAL STRENGTH
CE	2.00	11,000	34,000	550	257 °F	125 °C	17,500
G-3	2	42,000	76,000	375	347 °F	175 °C	55,000
G-7	0.19	25,000	40,000	350	428 °F	220 °C	18,500
G-10	0.10	51,000	66,000	800	302 °F	150 °C	65,000
G-11	0.08	43,000	58,000	550	400 °F	205 °C	58,000
XPN	1.50	18,000	45,000	600	266 °F	130 °C	29,000
XP	1.50	18,000	45,000	600	266 °F	130 °C	29,000



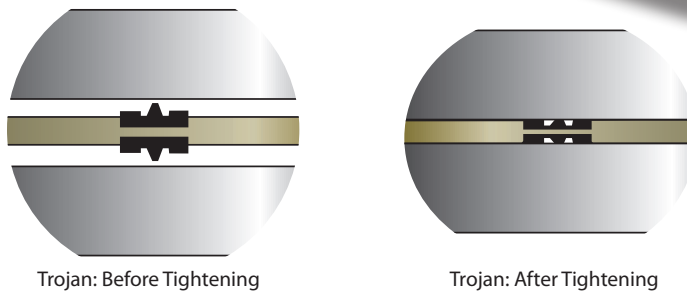
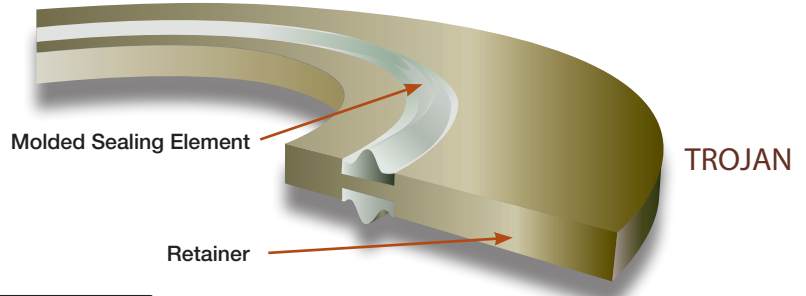
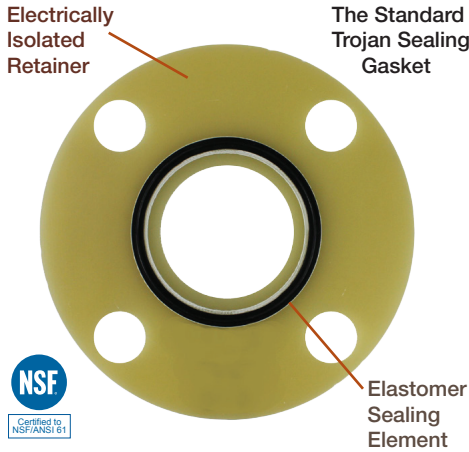

## TROJAN SEALING GASKETS

For near-zero-leakage static sealing, the Trojan gasket is a must. The elastomer sealing element is encapsulated in the electrically isolated retainer. Our most popular sealing element materials are Nitrile® (-60°/240 °F min./max. operating temperature), Viton® (-75°/400 °F), and PTFE (-425°/450 °F). The encapsulation of the sealing element permits only micro-exposure of the seal to hostile environments, chemicals and corrosive fluids.

The controlled confinement of the elastomer sealing ring within the retainer allows the availability of a 92% to 94% filled volume groove. A consistent controlled pressure seal can always be obtained without tremendous bolt loads. Reduced loads allow for reduced flange thickness with smaller circles and smaller bolt holes.

The cross section of APS' Trojan Sealing Gasket (A) shows the elastomer sealing element as it appears before compression between flanges. This compression causes the seal to effectively fill the void of the groove and encapsulate, (B) permitting only micro-exposure of the actual seal to hostile elements either from within or without.

All too often, difficult sealing situations arise from mismatched or misaligned flanges. A quick, cost effective solution is the APS Trojan and Trojan II. Also used in place of damaged or missing RTJ gaskets, the Trojan series forms a quick, static seal and is often the reasonable alternative to flange replacement.

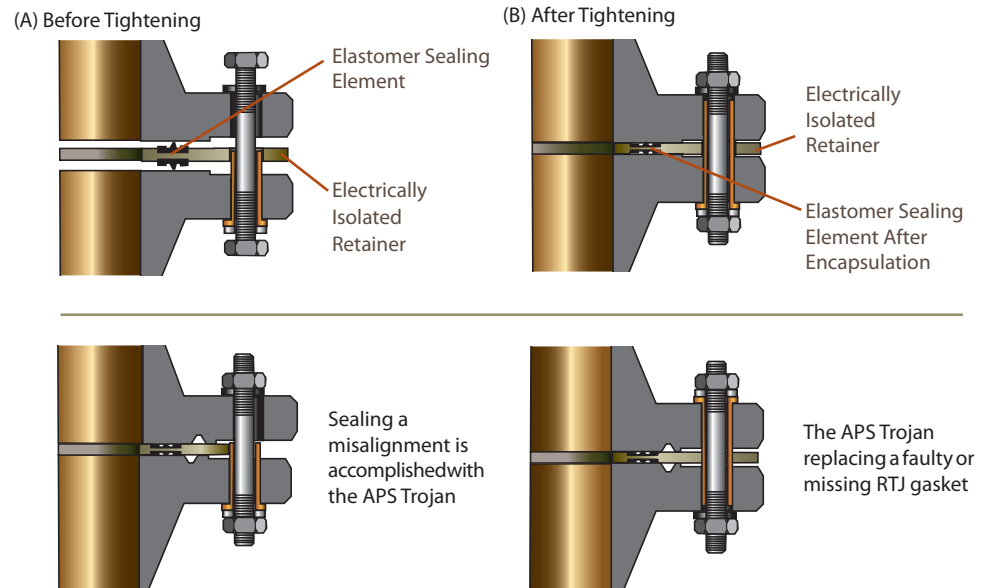

## Available Sealing Element Materials

SEAL MATERIALS	SEALING ELEMENTS			
	MIN OPERATING TEMPERATURE		MAX OPERATING TEMPERATURE	
	°F	°C	°F	°C
NITRILE	-60	-51.11	240	115.555
VITON	-75	-59.44	400	204.44
EPDM	-40	-40	250	121.11
PTFE	-425	-253.89	450	232.22

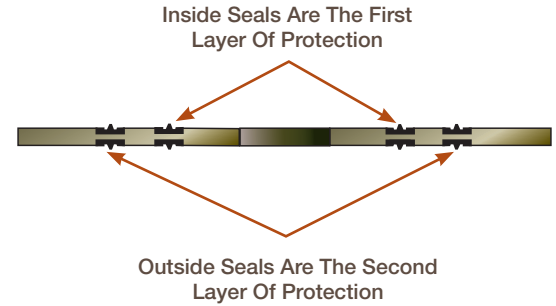
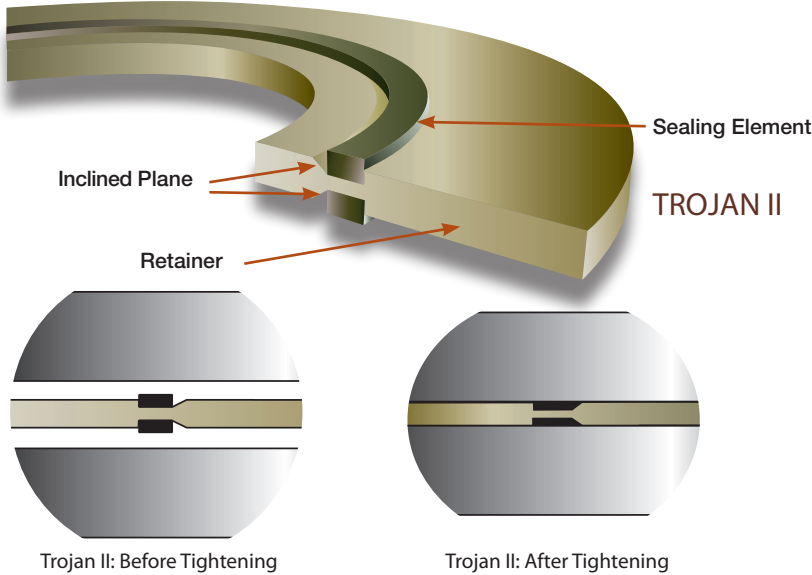

Cross Section Of The Duplex Seal Trojan Sealing Gasket

## DUPLEX SEAL TROJAN

Four seals on the new Duplex Seal Trojan further ensure the integrity of the sealing capability of an already proven reliable gasket. For areas where absolute zero leakage is a must, the Duplex Seal Trojan works twice as hard.

(A) Before Tightening

(B) After Tightening

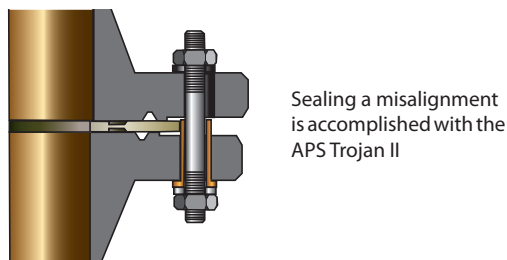
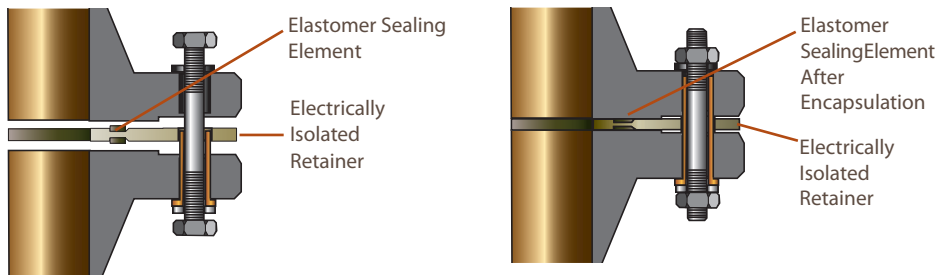

## WHY A DUPLEX SEAL?

The use of duplex seals on gaskets is primarily for two reasons: one, in the case that flange faces are slightly out of tolerance, the secondary seal will increase the chances of a successful seal. Two, the duplex seals can help in the circumstance of a seal groove (present) or a change of ID dimension of the two elements being connected. In the case that one of the sealing elements is not being compressed, the other one will be sufficient to accomplish a complete seal between flanges (as it did on past applications where dual seals were not standard practice).

## ADVANTAGES OF THE TROJAN & TROJAN II

- Can be utilized with mismatched flanges
- Can be utilized with misaligned flanges
- Can be used in place of RTJ rings
- Little initial torque required
- No re-torquing required
- Sealing ring cannot be left out
- Reusable
- Seal design tested for high pressures. Please consult factory for specific pressures
- Competitive price
- Limited area of seal exposed
- Compensates for pressure fluctuations, compression changes, vibrations, temperature, etc.
- Greatly reduces human error during installation
- Large selection of materials available
- Three to four times the dielectric strength necessary
- Low installation and maintenance costs
- Gaskets through 144"



### ISOLATING SLEEVES AND WASHERS

Isolating sleeves manufactured in various materials and sizes, with standard 1/32" wall thickness, are available to meet every customer's needs. Also available are one-piece integral sleeves and washers which are made of Minlon, providing superior compression strength. Integral sleeves are available in sizes through 1-1/2". A variety of high temperature sleeves are also stock items.

With each isolating washer, an S.A.E. electroplated steel washer is provided to protect the isolating washer from damage by the nut. Advance flange isolation sets are available in single or double washer kits.



### KLEERBAND® FLANGE PROTECTORS

An additional high level of corrosion protection can be attained with the use of Kleerband® flange protectors, stainless steel flange protectors and Radolid® protection caps.

Flange protectors and corrosion inhibitor grease are recommended on all isolated flanges. By encapsulating the flange cavity with the flange protector and injecting our corrosion inhibitor grease, you can rely on your cathodic protection system to provide you with years of trouble free service.

This system totally eliminates any possibility of foreign material lodging between the faces of your flange or corrosion bridging across and creating a short.

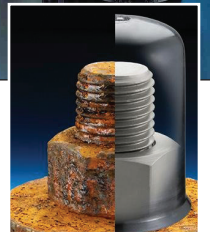

### RADOLID® PROTECTION CAPS WITH VCI\*

Radolid® protection caps from APS protect nuts and bolts from destructive corrosion. Caps are easily pressed onto the bolted joints by hand, snapping into place when in position. We recommend loading caps with APS' Kleerger®, a high-melt corrosion inhibitor grease, for added protection.

\*Volatile Corrosion Inhibitors

Isolating Material				
MATERIAL	DIELECTRIC STRENGTH VOLTS/MIL	WATER ABSORPTION %	MAX CONTINUOUS OPERATING TEMPERATURE	
Mylar	4,000	.8	300 ° F	149 ° C
Minlon	1,200	.22	250 ° F	121 ° C
Nomex	500	-	450 ° F	232 ° C
G-10	800	.10	302 ° F	150 ° C
G-3	375	2	347 ° F	175 ° C
G-7	350	.19	428 ° F	220 ° C
G-11	550	.08	400 ° F	205 ° C

## HIGH TEMPERATURE PRODUCTS

**GASKETS:** NEMA grades G-3, G-7, G-10, G-11, Durabla and Durlon

**SLEEVES:** Nomex, NEMA grades G-7 and G-10, Durabla, Durlon

**WASHERS:** NEMA grades G-7 and G-10, Durabla, Durlon

Other high temperature materials are available upon request. It is recommended that the factory be contacted to discuss technical data on the above referenced products.

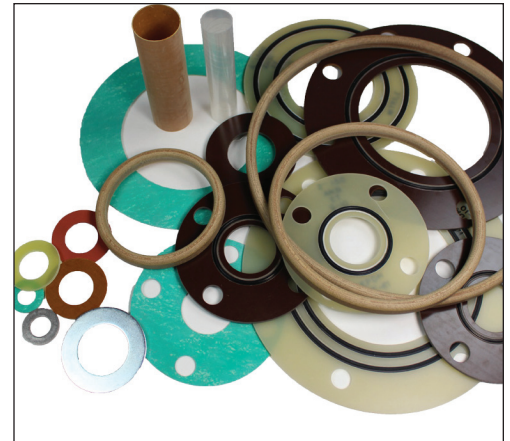

## SPECIAL APPLICATION

Advance Products and Systems, LLC is well equipped to make those special isolation pads and gaskets sometimes required for odd shaped connections. We can manufacture any configuration or design needed.

These applications include special closures, vaults, steel boxes, special connectors and utility and light poles.

If it needs to be sealed, we can be of service.



## PACKAGING

Each Advance flange isolation gasket kit is packaged individually in durable corrugated boxes. Isolating sleeves and washers are packaged separately and are cushioned within the box to protect them from damage during shipment. Each set is clearly tagged with flange size, pressure rating, type of isolating sleeve and whether it is a single washer or double washer set. A recommended bolt tightening sequence is provided with each kit.



## TO ORDER PLEASE SPECIFY THE FOLLOWING

- Gasket Type D, E or F
- Flange Size and Pressure Rating
- Single Washer or Double Washer Sets (SW or DW)
- Sleeve Material
- Retainer Material
- Sealing Element (Nitrile®, Viton® or PTFE)

## OTHER QUALITY PRODUCTS AVAILABLE FROM ADVANCE PRODUCTS & SYSTEMS, LLC

- Flange Band Protectors - Stainless Steel & Kleerband®
- Radolid® Nut & Bolt Protector Caps
- Casing Spacers and End Seals
- Specialty Products Manufactured of Phenolic and other materials
- Innerlynx® - Wall/Pipe Penetration Seals & Wall Sleeves
- Isojoint® - Monolithic Isolating Joints
- Foreman Nite Caps
- Duocon® Centralizers
- Safety Spray Shields
- UBolt-Cote®



**ADVANCE**  
PRODUCTS & SYSTEMS, LLC

P. O. Box 60399 • Lafayette, Louisiana 70596-0399  
800-315-6009 • 337-233-6116 • FAX: 337-232-3860  
Email: sales@apsonline.com • Website: www.apsonline.com



Distributed by:

Advance Products & Systems, LLC is not responsible for errors printed in this brochure.

Advance Products & Systems, LLC shall repair or replace (within the limitations of such applicable express written warranty as may be issued by it) any product or portions thereof, which prove to be defective in workmanship or material for a period of 12 months from shipment date. The foregoing in lieu of all warranties, express or implied, and all other obligations or liabilities on the part of APS, on account of the product which it may sell. In no event shall APS be liable for consequential or special damages: nor except as it may otherwise specifically agree in writing, installation, or other work which may be done upon or in connection with the product by APS/ the distribution / dealer or others. THE LIMITED WARRANTIES PROVIDED IN THIS AGREEMENT AND THE OBLIGATIONS AND LIABILITIES OF APS ARE THE ONLY WARRANTIES MADE BY APS AS TO THE PRODUCT. APS MAKES NO EXPRESS OR OTHER IMPLIED WARRANTIES, BY COURSE OF DEALING, USAGE OF TRADE, MERCHANTABILITY, FITNESS FOR A PARTICULAR USE (WHETHER GENERAL OR SPECIFIC), OR OTHERWISE.