



US 20200266173A1

(19) **United States**

(12) **Patent Application Publication**

Nakano

(10) **Pub. No.: US 2020/0266173 A1**

(43) **Pub. Date: Aug. 20, 2020**

(54) **METHODS FOR FABRICATING 3D SEMICONDUCTOR DEVICE PACKAGES, RESULTING PACKAGES AND SYSTEMS INCORPORATING SUCH PACKAGES**

H01L 25/18 (2006.01)
H01L 25/065 (2006.01)
H01L 21/78 (2006.01)
H01L 21/683 (2006.01)

(52) **U.S. Cl.**

CPC *H01L 24/94* (2013.01); *H01L 2924/1436* (2013.01); *H01L 25/18* (2013.01); *H01L 25/0657* (2013.01); *H01L 24/11* (2013.01); *H01L 21/78* (2013.01); *H01L 21/6835* (2013.01); *H01L 2224/13147* (2013.01); *H01L 2224/13082* (2013.01); *H01L 2224/11* (2013.01); *H01L 2221/68381* (2013.01); *H01L 2221/68372* (2013.01); *H01L 2221/68327* (2013.01); *H01L 2221/6834* (2013.01); *H01L 2225/06541* (2013.01); *H01L 2924/1434* (2013.01); *H01L 25/50* (2013.01)

(71) Applicant: **Micron Technology, Inc.**, Boise, ID (US)

(72) Inventor: **Eiichi Nakano**, Boise, ID (US)

(21) Appl. No.: **16/869,324**

(22) Filed: **May 7, 2020**

Related U.S. Application Data

(60) Continuation of application No. 16/392,221, filed on Apr. 23, 2019, which is a division of application No. 15/976,398, filed on May 10, 2018, now Pat. No. 10,319,696.

Publication Classification

(51) **Int. Cl.**

H01L 23/00 (2006.01)
H01L 25/00 (2006.01)

(57)

ABSTRACT

Methods of forming semiconductor device packages comprising stacking multiple dice, the die stack exhibiting thin bond lines and having an outer environmental coating, the bond lines and environmental coating comprising an in situ formed compound. Semiconductor device packages so formed and electronic systems incorporating such packages are also disclosed.

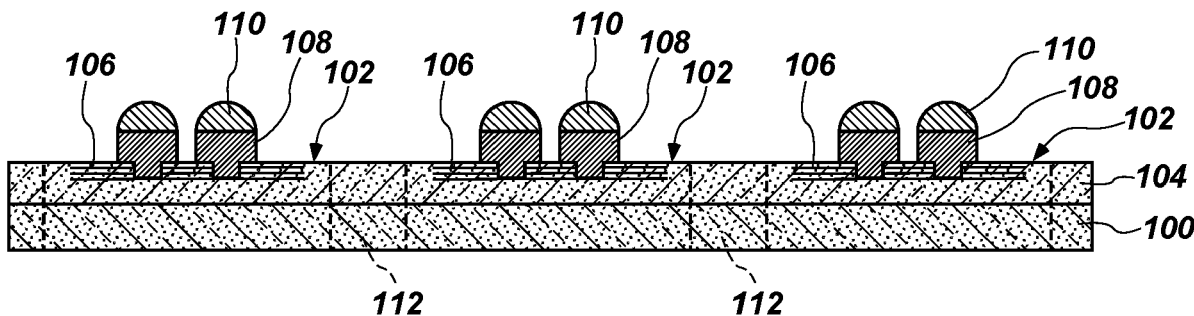

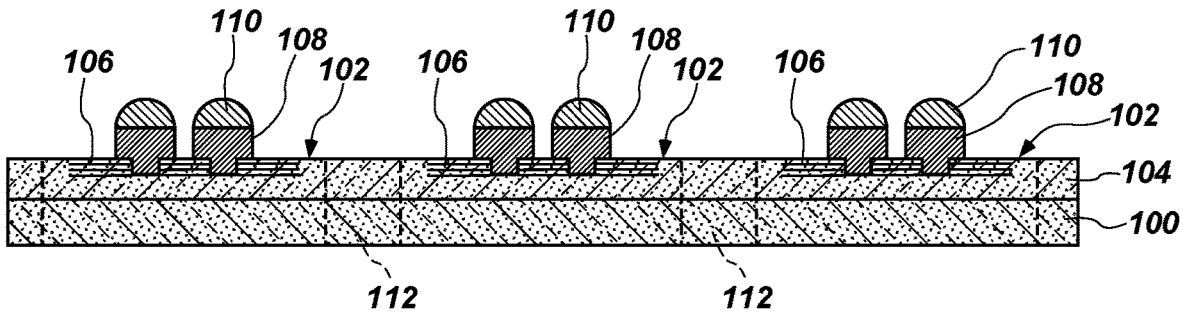

FIG. 1

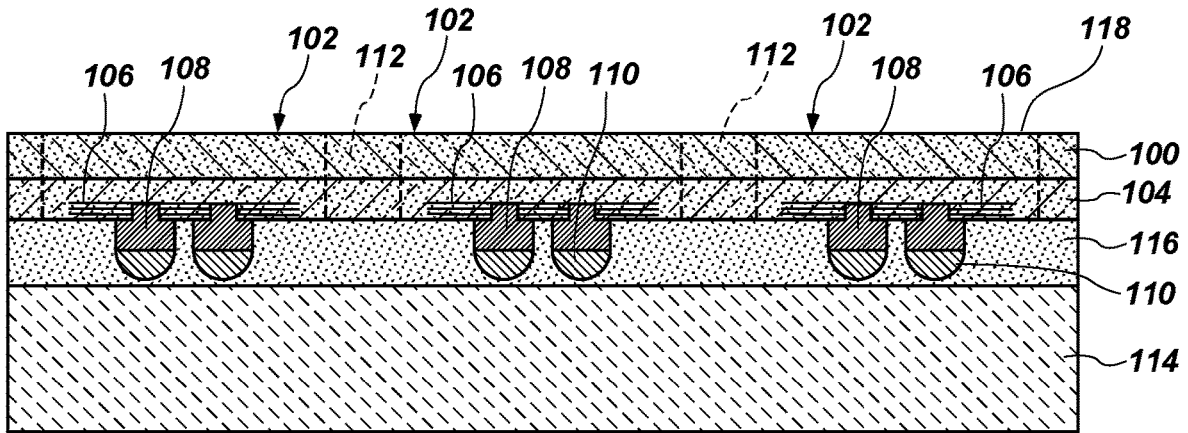

FIG. 2

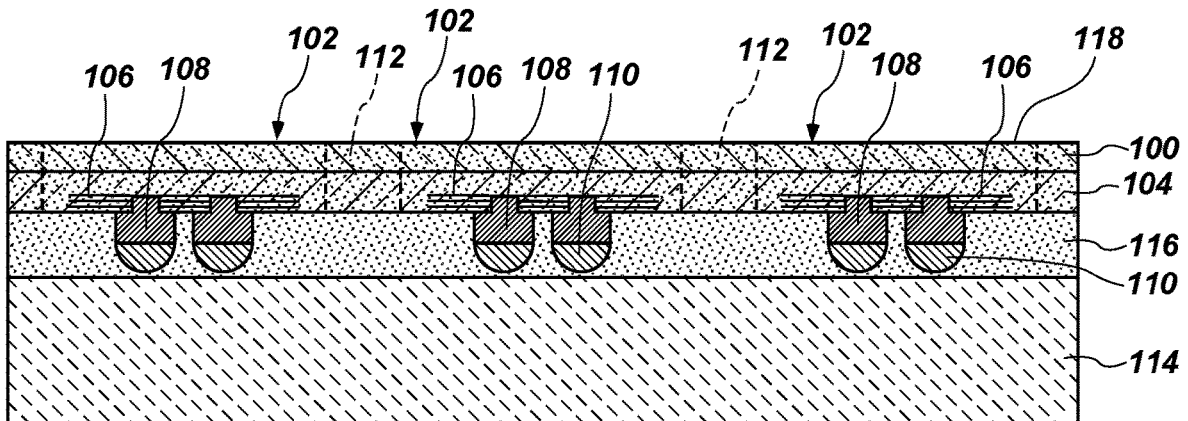

FIG. 3

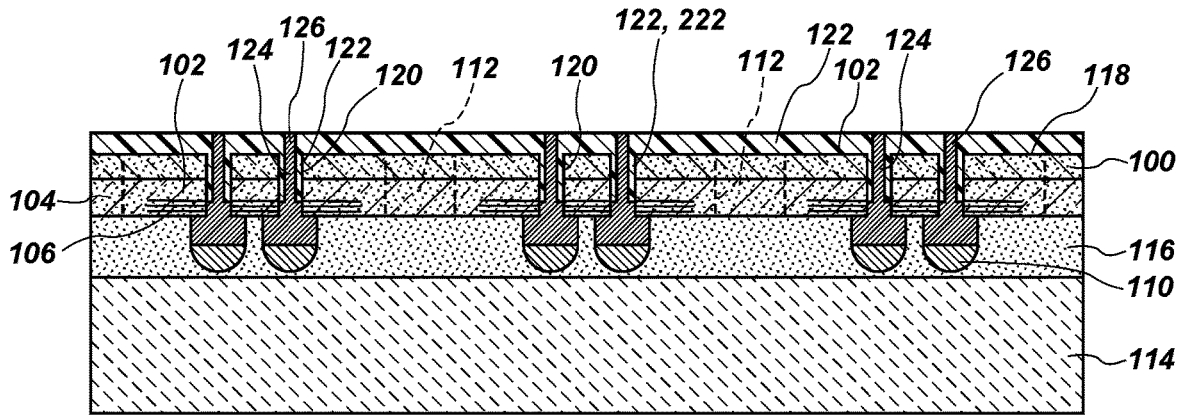

FIG. 4

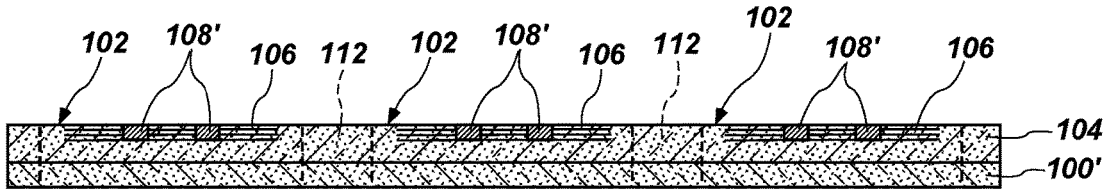
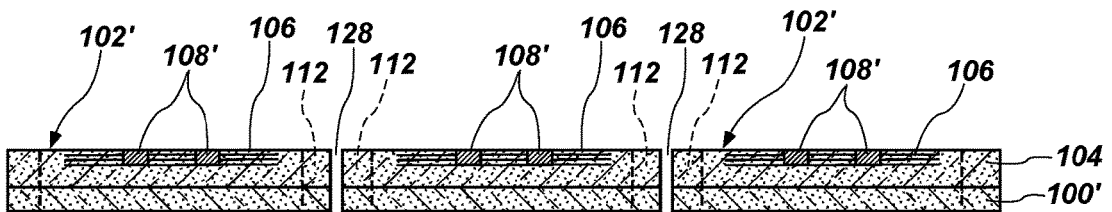

FIG. 5A



102'

118'

FIG. 5B

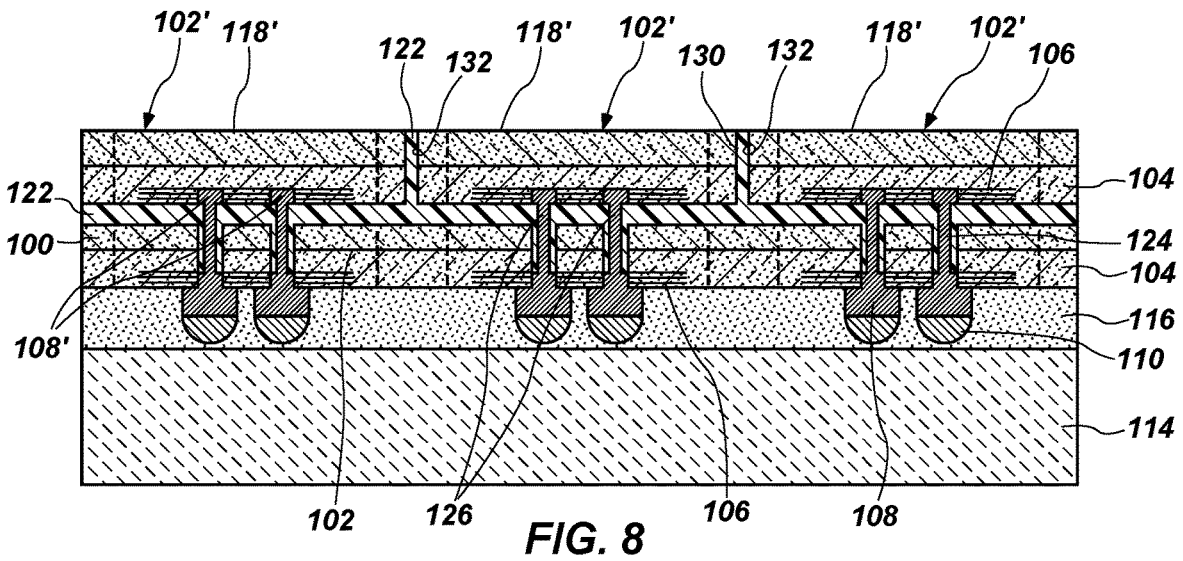
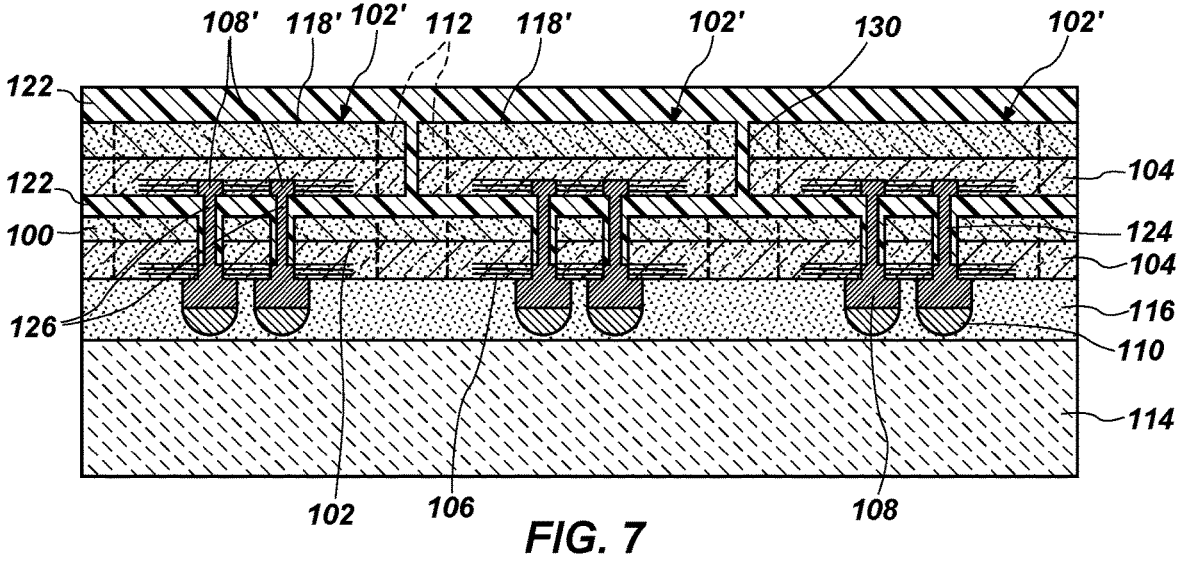
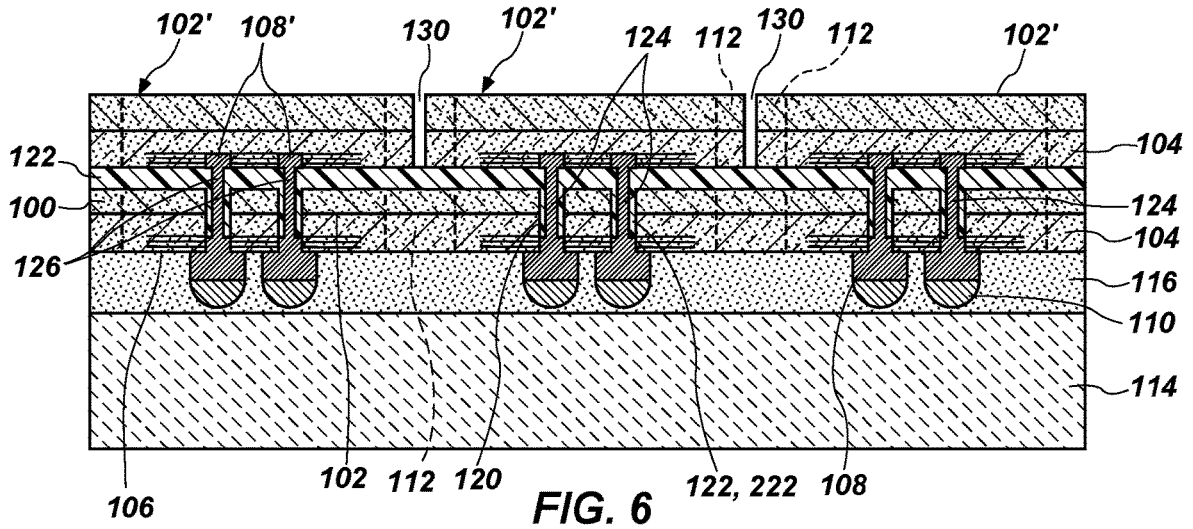

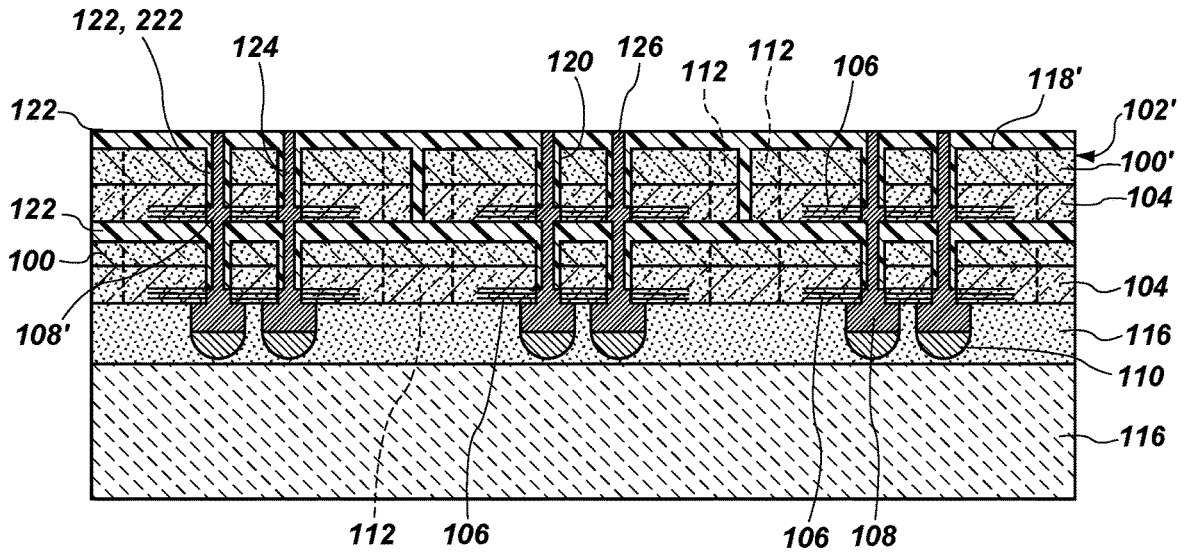

FIG. 9

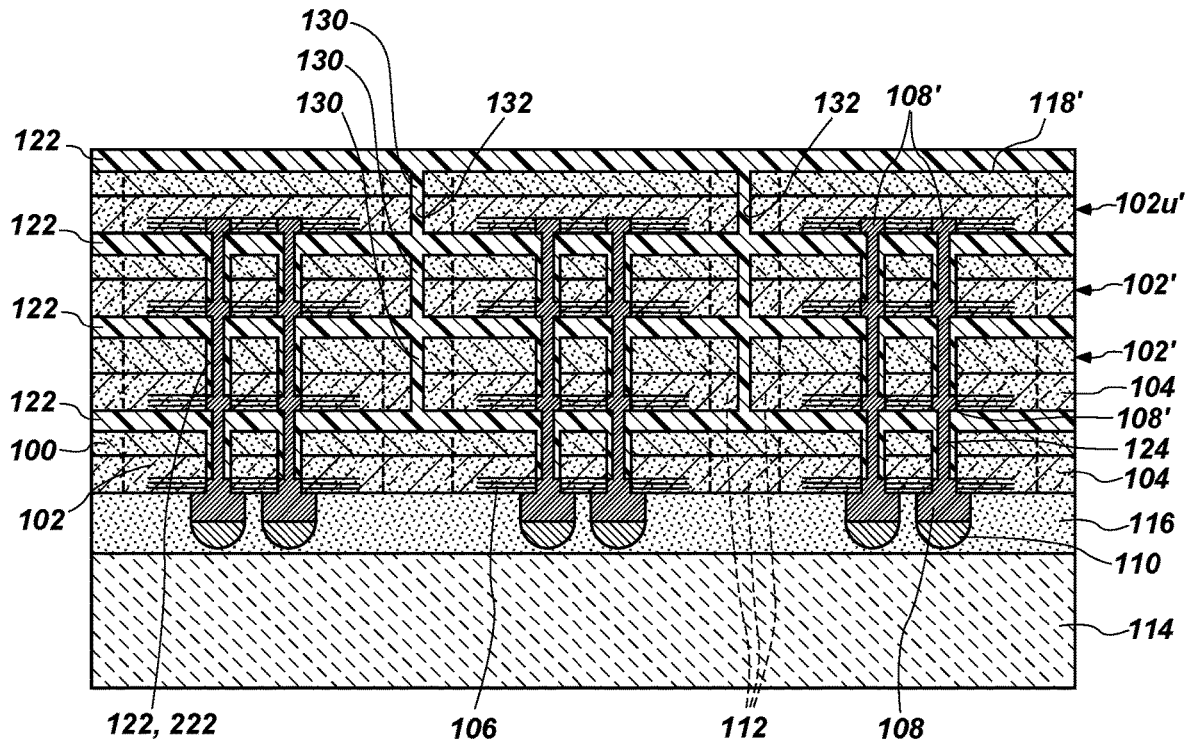

FIG. 10

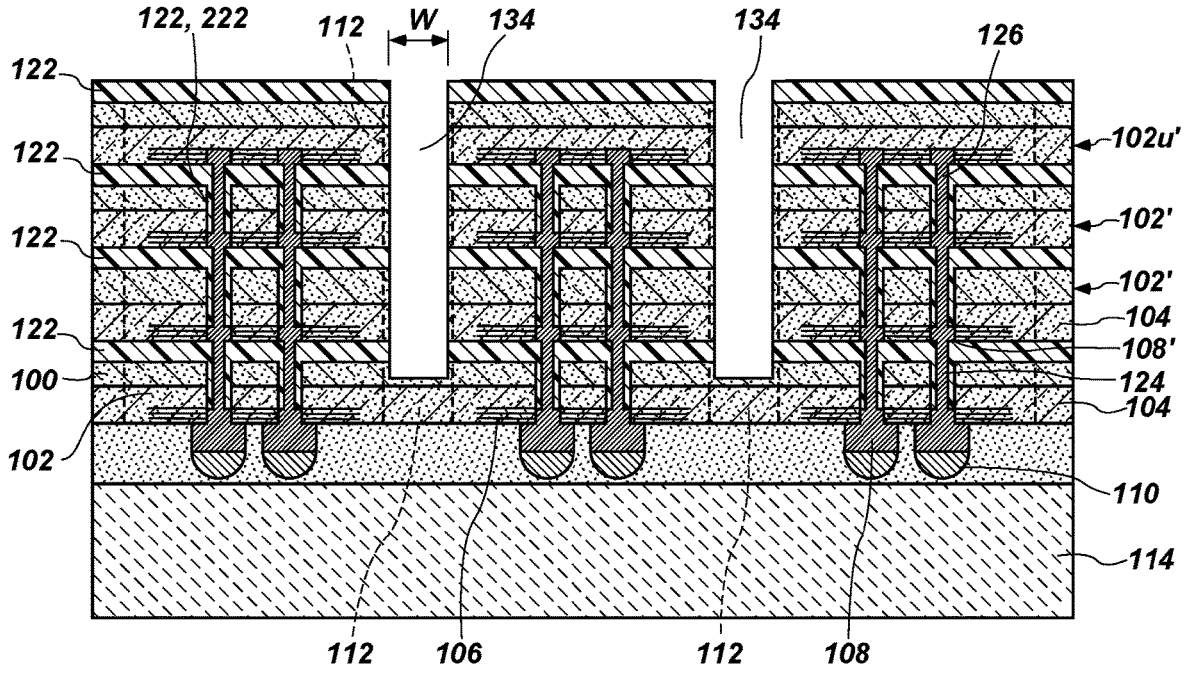

FIG. 11

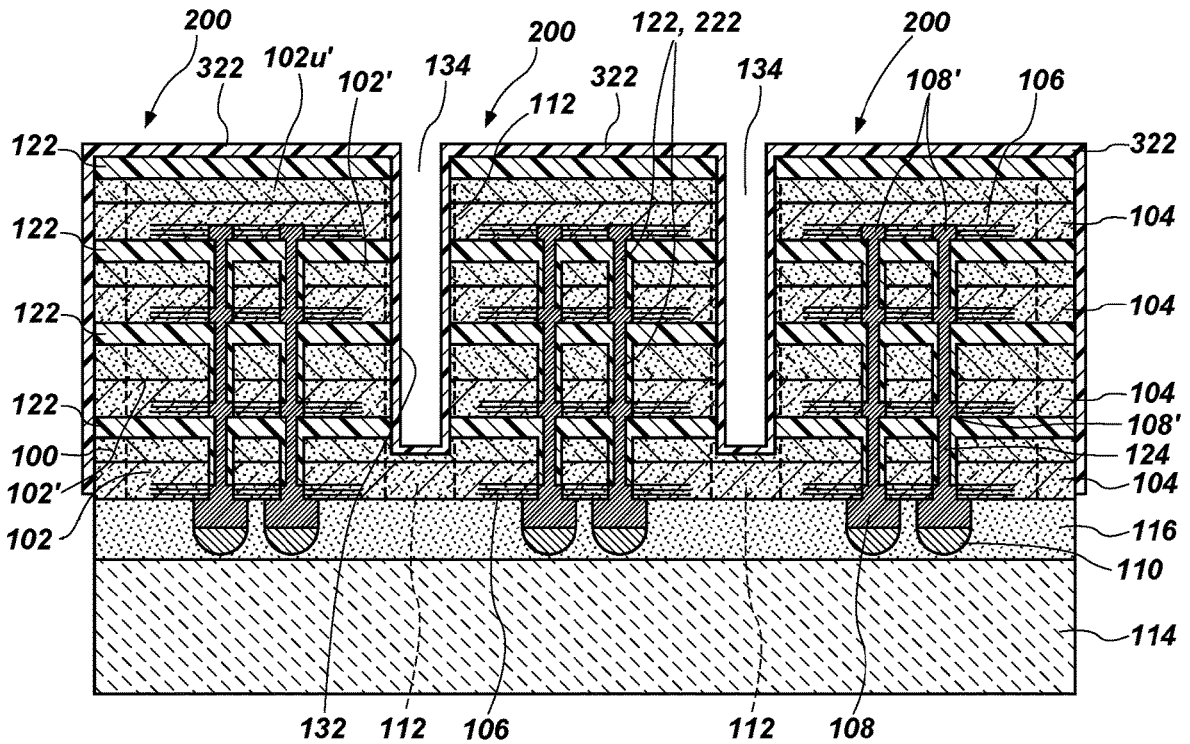

FIG. 12

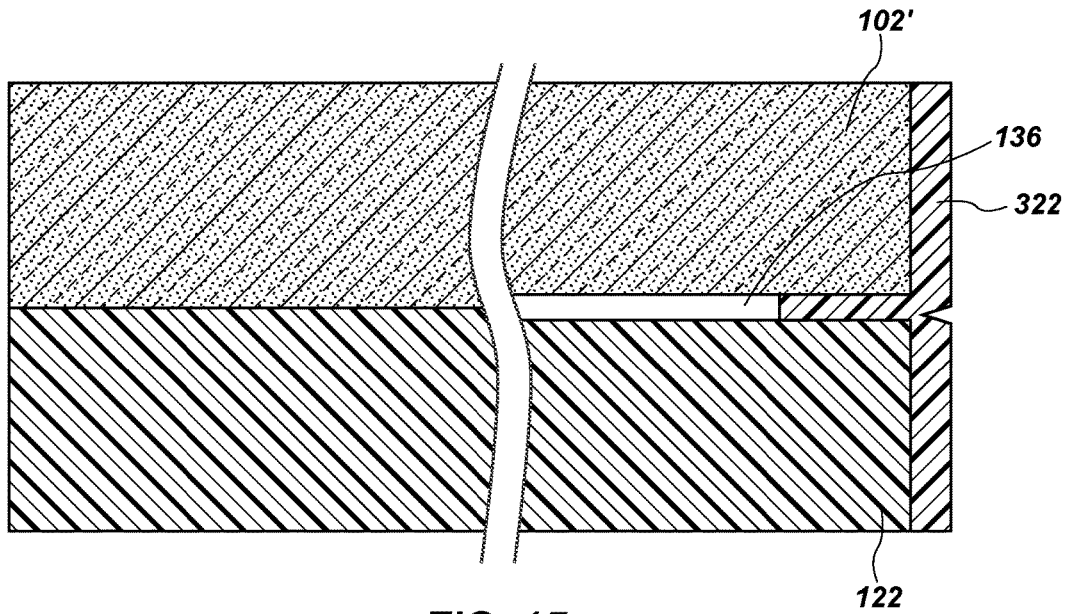

FIG. 15

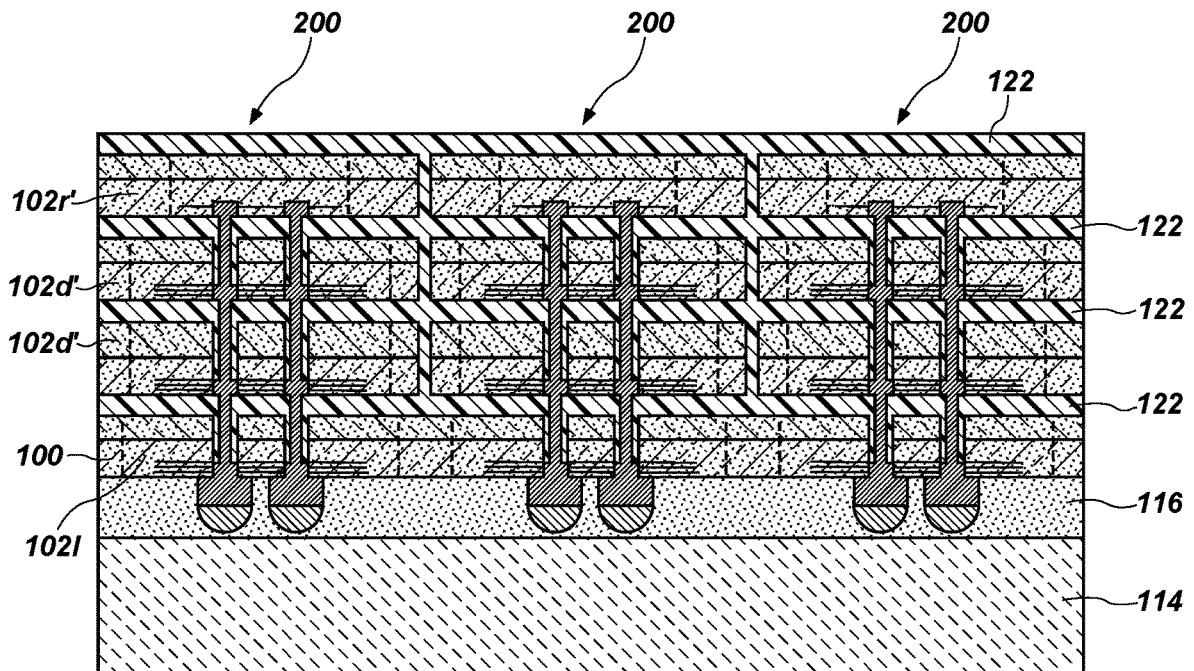

FIG. 16A

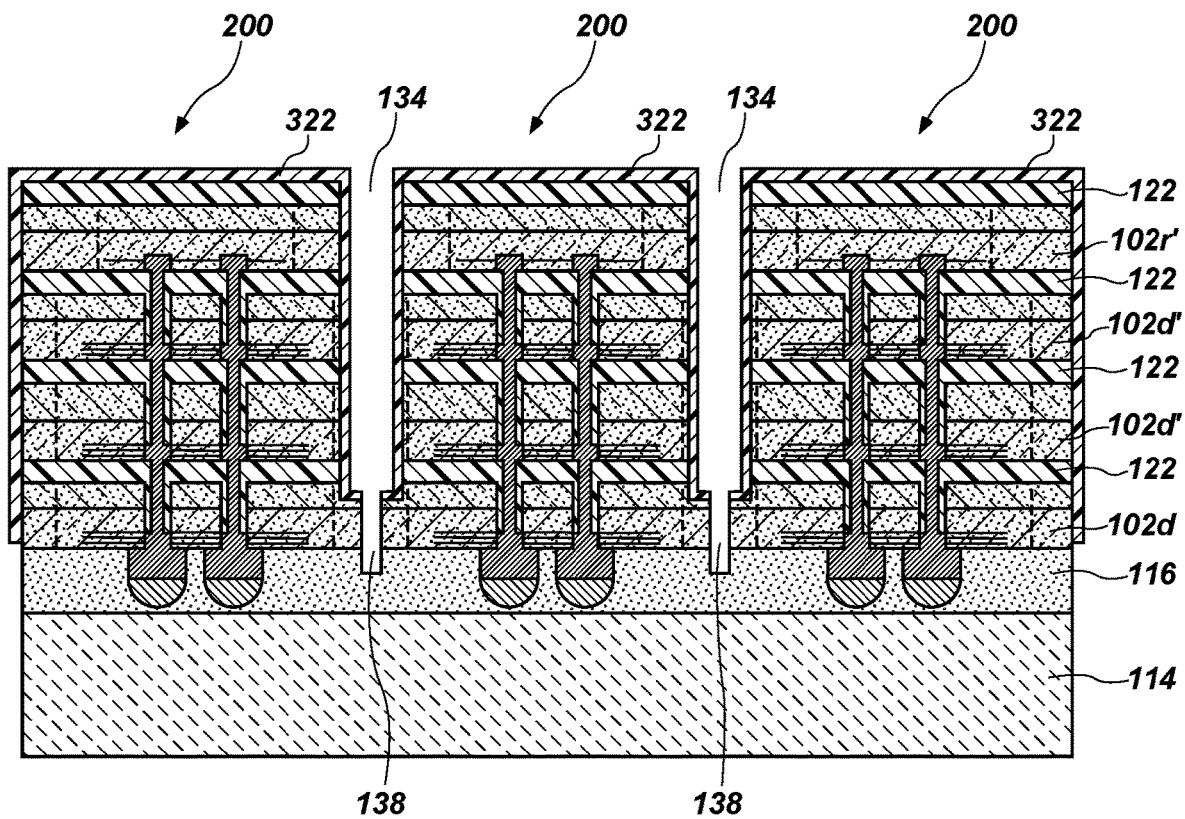

FIG. 16B

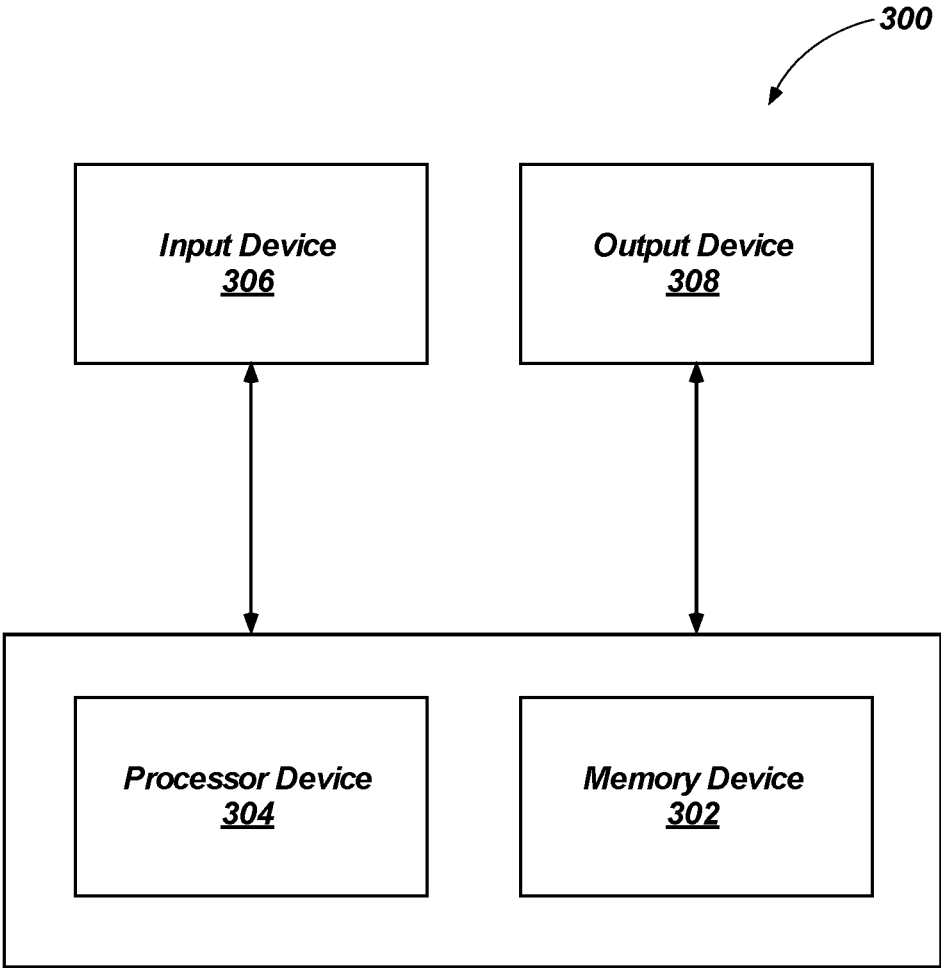

FIG. 17

**METHODS FOR FABRICATING 3D
SEMICONDUCTOR DEVICE PACKAGES,
RESULTING PACKAGES AND SYSTEMS
INCORPORATING SUCH PACKAGES**

CROSS-REFERENCE TO RELATED
APPLICATIONS

[0001] This application is a continuation of U.S. patent application Ser. No. 16/392,221, filed Apr. 23, 2019, which will issue as U.S. Pat. No. 10,651,145 on May 12, 2020, which prior application is a divisional of U.S. patent application Ser. No. 15/976,398, filed May 10, 2018, now U.S. Pat. No. 10,319,696, issued Jun. 11, 2019, the disclosure of each of which is hereby incorporated herein in its entirety by this reference.

TECHNICAL FIELD

[0002] Embodiments disclosed herein relate to methods of fabricating packages comprising multiple semiconductor dice. More particularly, embodiments disclosed herein relate to methods for fabricating three-dimensional packages comprising multiple, stacked semiconductor dice, resulting packages and systems incorporating such packages.

BACKGROUND

[0003] As the electronics industry has evolved and encompassed more and different applications, for example, smart phones and other mobile devices, increasingly compact personal (laptop and tablet) computers, artificial intelligence, the Internet of Things and cloud computing, there is an ever-increasing demand for high density, small form factor modular packages comprising stacked semiconductor dice. In such an instance, form factor includes not only the footprint (length and width) of a package but also the height, a significant consideration in mobile applications among others. Such demand is not only directed toward memory die packages, but also toward packages comprising not only memory dice but also memory dice in combination with one or more of logic, processor and radiofrequency (RF) dice.

[0004] While it has been demonstrated to be possible to fabricate such packages, the ability to do so to provide a small form factor at a reasonable cost and acceptable yield on a commercial scale has to date, eluded the semiconductor industry.

BRIEF DESCRIPTION OF THE DRAWINGS

[0005] FIGS. 1 through 14 are schematic cross-sectional views of an embodiment of a method of fabricating a semiconductor device package according to an embodiment of the disclosure;

[0006] FIG. 15 is an enlarged schematic cross-sectional view of a portion of a semiconductor die of a package according to embodiments of the disclosure;

[0007] FIG. 16A is a schematic cross-sectional view of a semiconductor device package fabricated according to an embodiment of the disclosure and including memory dice and an RF die;

[0008] FIG. 16B is a schematic cross-sectional view of a semiconductor device package fabricated according to an embodiment of the disclosure and including memory dice and a logic die; and

[0009] FIG. 17 is a block diagram of an electronic system including at least one semiconductor device package according to one or more embodiments of the disclosure.

DETAILED DESCRIPTION

[0010] Methods of fabricating semiconductor device packages comprising multiple, stacked semiconductor dice are disclosed. In some embodiments, the packages comprise only memory dice, while in other embodiments the packages comprise memory dice and at least one other type of die, for example, a processor, logic or radiofrequency (RF) die.

[0011] The following description provides specific details, such as sizes, shapes, material compositions, and orientations in order to provide a thorough description of embodiments of the disclosure. However, a person of ordinary skill in the art would understand that the embodiments of the disclosure may be practiced without necessarily employing these specific details. Embodiments of the disclosure may be practiced in conjunction with conventional fabrication techniques employed in the industry. In addition, the description provided below does not form a complete process flow for manufacturing a semiconductor device package, a semiconductor device package, or a higher-level assembly including a semiconductor device package. Only those process acts and structures necessary to understand the embodiments of the disclosure are described in detail below. Additional acts to form a complete semiconductor device package, or higher-level assembly including a semiconductor device package from process and package described herein may be performed by conventional fabrication processes.

[0012] Drawings presented herein are for illustrative purposes only, and are not meant to be actual views of any particular material, component, structure, device, or system. Variations from the shapes depicted in the drawings as a result, for example, of manufacturing techniques and/or tolerances, are to be expected. Thus, embodiments described herein are not to be construed as being limited to the particular shapes or regions as illustrated, but include deviations in shapes that result, for example, from manufacturing. For example, a region illustrated or described as box-shaped may have rough and/or nonlinear features, and a region illustrated or described as round may include some rough and/or linear features. Moreover, sharp angles between surfaces that are illustrated may be rounded, and vice versa. Thus, the regions illustrated in the figures are schematic in nature, and their shapes are not intended to illustrate the precise shape of a region and do not limit the scope of the present claims. The drawings are not necessarily to scale.

[0013] As used herein, the terms “comprising,” “including,” “containing,” “characterized by,” and grammatical equivalents thereof are inclusive or open-ended terms that do not exclude additional, unrecited elements or method acts, but also include the more restrictive terms “consisting of” and “consisting essentially of” and grammatical equivalents thereof. As used herein, the term “may” with respect to a material, structure, feature or method act indicates that such is contemplated for use in implementation of an embodiment of the disclosure and such term is used in preference to the more restrictive term “is” so as to avoid any implication that other, compatible materials, structures, features and methods usable in combination therewith should or must be, excluded.

[0014] As used herein, the terms “longitudinal,” “vertical,” “lateral,” and “horizontal” are in reference to a major

plane of a substrate (e.g., base material, base structure, base construction, etc.) in or on which one or more structures and/or features are formed and are not necessarily defined by earth's gravitational field. A "lateral" or "horizontal" direction is a direction that is substantially parallel to the major plane of the substrate, while a "longitudinal" or "vertical" direction is a direction that is substantially perpendicular to the major plane of the substrate. The major plane of the substrate is defined by a surface of the substrate having a relatively large area compared to other surfaces of the substrate.

[0015] As used herein, spatially relative terms, such as "beneath," "below," "lower," "bottom," "above," "over," "upper," "top," "front," "rear," "left," "right," and the like, may be used for ease of description to describe one element's or feature's relationship to another element(s) or feature(s) as illustrated in the figures. Unless otherwise specified, the spatially relative terms are intended to encompass different orientations of the materials in addition to the orientation depicted in the figures. For example, if materials in the figures are inverted, elements described as "over" or "above" or "on" or "on top of" other elements or features would then be oriented "below" or "beneath" or "under" or "on bottom of" the other elements or features. Thus, the term "over" can encompass both an orientation of above and below, depending on the context in which the term is used, which will be evident to one of ordinary skill in the art. The materials may be otherwise oriented (e.g., rotated 90 degrees, inverted, flipped) and the spatially relative descriptors used herein interpreted accordingly.

[0016] As used herein, the singular forms "a," "an," and "the" are intended to include the plural forms as well, unless the context clearly indicates otherwise.

[0017] As used herein, the terms "configured" and "configuration" refer to a size, shape, material composition, orientation, and arrangement of one or more of at least one structure and at least one apparatus facilitating operation of one or more of the structure and the apparatus in a predetermined way.

[0018] As used herein, the term "substantially" in reference to a given parameter, property, or condition means and includes to a degree that one of ordinary skill in the art would understand that the given parameter, property, or condition is met with a degree of variance, such as within acceptable manufacturing tolerances. By way of example, depending on the particular parameter, property, or condition that is substantially met, the parameter, property, or condition may be at least 90.0% met, at least 95.0% met, at least 99.0% met, or even at least 99.9% met.

[0019] As used herein, the term "about" in reference to a given parameter is inclusive of the stated value and has the meaning dictated by the context (e.g., it includes the degree of error associated with measurement of the given parameter).

[0020] As used herein the terms "layer" and "film" mean and include a level, sheet or coating of material residing on a structure, which level, sheet or coating may be continuous or discontinuous between portions of the material, and which may be conformal or non-conformal, unless otherwise indicated.

[0021] As used herein the term "wafer" means and includes not only a conventional, substantially circular wafer of a single material, such as single crystal silicon, but also other bulk substrates in the form of a silicon-on-

insulator (SOI) structure, as well as bulk substrates comprising other semiconductor materials, for example, germanium, or gallium arsenide.

[0022] As used herein, the term "compound" means and includes a material consisting of two or more different types of atoms in a fixed, stoichiometric or non-stoichiometric proportion and having a unique chemical structure held together in defined spatial arrangement by chemical bonds.

[0023] FIG. 1 is a schematic, cross-sectional view of a base semiconductor wafer, for example, a silicon wafer **100**, comprising multiple die locations **102**. Each die location **102** comprises an active surface, which may also be characterized as a device layer **104**, comprising active circuitry **106**, for example, memory circuitry in the form of dynamic random access memory (DRAM) circuitry or NAND flash memory circuitry. Active circuitry **106** is in electrical communication with external conductive elements in the form of, for example, copper pillars **108** having (optional) solder caps **110** thereon. FIG. 1 also denotes scribe areas **112** in silicon wafer **100**, delineating so-called "streets" between adjacent semiconductor die locations **102**.

[0024] FIG. 2 is a schematic, cross-sectional view of silicon wafer **100** inverted from an orientation shown in FIG. 1 and secured to a carrier substrate **114**, which may comprise silicon, a glass, a ceramic, or other suitable material. Wafer **100** is secured to carrier substrate **114** with a temporary adhesive **116**, for example, a thermal release adhesive, a solvent release adhesive, or an ultraviolet (UV) release adhesive, with copper pillars **108** and (optional) solder caps **110** embedded in the temporary adhesive **116** and back side **118** of silicon wafer **100** facing away from carrier substrate **114**.

[0025] In FIG. 3, silicon wafer **100**, while secured to carrier substrate **114**, has been thinned from its back side **118**, for example, from an initial thickness of about 600 μm to about 700 μm to a final thickness of between about 30 μm to about 70 μm . Thinning may be effected by, for example, coarse back grinding followed by fine grinding or polishing, wet (chemical) etching, or dry plasma etching, or by chemical mechanical planarization (CMP). Of course, the process or processes employed in thinning are related to whether through vias are preformed in wafer **100** or formed after attachment to a carrier substrate, as described below.

[0026] As shown in FIG. 4, after silicon wafer **100** is thinned, in one embodiment a dielectric material **122**, which may also be characterized as a dielectric bond line material, is formed on the back side **118**, after which through vias **120** are formed, example, by anisotropic (e.g., reactive ion) etching, through the dielectric material **122** on the back side **118** of wafer **100** and extending through wafer **100** to electrically connect to active circuitry **106**. Through vias **120** are lined with a dielectric material **222** and via conductors **124** comprising conductive pillars **126**, for example, of a metal such as copper, are formed by a deposition process. In another embodiment, through vias **120** are formed before dielectric material **122** is formed, and a common dielectric material **122** lines through vias **120** and extends over back side **118** of wafer **100**. Via conductor **124** and integral conductive pillar **126** are then formed. Dielectric material **122** may be a non-polymeric material, be devoid of filler material and may comprise, for example, a silicon oxide (e.g., SiO_2), a silicon nitride (e.g., Si_3N_4), a silicon oxynitride (e.g., SiO_xN_y), or a TEOS oxide or an O_3 /TEOS oxide, as disclosed in U.S. Patent Publication No. US 2017/

01486674 A1, assigned to the Assignee of the present disclosure. Dielectric material 122 may be formed as a compound in situ by chemical vapor deposition (CVD), atomic layer deposition (ALD), plasma enhanced chemical vapor deposition (PECVD), sub atmospheric chemical vapor deposition (SACVD) physical vapor deposition, atmospheric pressure plasma deposition, or other known technique. Dielectric material 222, if employed, may comprise one of the above-referenced materials and comprise the same, or a different dielectric material than dielectric material 122.

[0027] In another embodiment, through vias 120 may be preformed as blind vias lined with a dielectric material 222 and comprising via conductors 124 in wafer 100 prior to thinning thereof as illustrated in FIG. 3. Conductors 124 are then exposed by etching from the back side 118 of wafer 100 to provide conductive pillars 126 protruding from the back side 118, after which another dielectric material 122 may be applied as a layer over back side 118 of wafer 100 to arrive at the structure shown in FIG. 4.

[0028] In any of the foregoing embodiments, dielectric material 122 as formed is extremely thin, on the order of about 10 μm to about 25 μm , to provide a very narrow bond line with a subsequently placed semiconductor die, as described below.

[0029] FIGS. 5A and 5B depict another wafer 100' comprising semiconductor die locations 102, each bearing active circuitry 106 on a device layer 104 operably coupled to terminal pads 108', which may comprise copper and which may also be characterized as bond pads. Semiconductor die locations 102 are separated by scribe areas 112. Wafer 100' as shown has, like wafer 100, been thinned from an initial thickness of about 600 μm to about 700 μm to a final thickness of between about 30 μm to about 70 μm . As shown in FIG. 5B, wafer 100' has been separated, or "singulated," at cut 128 through scribe areas 112 into individual semiconductor dice 102'. Notably, as shown in FIG. 5B, the singulation is effected with a very narrow dicing saw blade width, leaving a substantial width of semiconductor material within scribe area 112 intact on each side of cut 128.

[0030] In FIG. 6, a first level of individual semiconductor dice 102' singulated from a wafer 100' and preferably comprising known good die (KGD) have been placed in mutually laterally spaced relationship, using conventional pick-and-place equipment, on wafer 100, each semiconductor die 102' superimposed on a semiconductor die location 102 of wafer 100 with terminal pads 108', aligned with conductive pillars 126 of an underlying semiconductor die location 102. Electrical coupling between conductive pillars 126 and terminal pads 108' may be effected, for example, by diffusion bonding of a copper pillar 126 to a copper terminal pad 108', or by dielectric bonding between each semiconductor die 102' and dielectric material 122 over its corresponding underlying semiconductor die location 102, using dielectric material 122 previously applied to the back side 118 of wafer 100. Dielectric bonding may be effected as known in the art, for example, as disclosed in U.S. Pat. No. 9,391,143. With either technique, a very thin bond line may be achieved while ensuring mutual electrical and mechanical coupling between adjacent semiconductor dice 102' and between a semiconductor die location 102 and the adjacent semiconductor die 102'. Due to thermal budget and process

time issues, diffusion bonding or dielectric bonding may be effected after all levels of semiconductor dice 102' are stacked.

[0031] In FIG. 7, another dielectric material 122 is applied over and covers the back sides 118' of semiconductor dice 102' and extends into spaces 130 between adjacent semiconductor dice 102'.

[0032] As shown in FIG. 8, a chip-on-wafer (COW) thinning process has been performed to remove excess dielectric material 122 over the back sides 118' of semiconductor dice 102', leaving dielectric material 122 in spaces 130 between adjacent semiconductor dice 102' and over exposed side surfaces 132 thereof.

[0033] Subsequently, as shown in FIG. 9, yet another dielectric material 122 is disposed over the back sides 118' of semiconductor dice 102'. Through vias 120 extending to active circuitry 106 of each semiconductor dice 102' are then formed from the back sides 118' thereof through dielectric material 122 by a conventional technique. Through vias 120 are then lined with a dielectric material 222 and filled with a conductive material, for example, copper, to form conductors 124 comprising conductive pillars 126 protruding above back sides 118' of semiconductor dice 102' and to the surface of dielectric material 122.

[0034] In another embodiment, the first level of singulated semiconductor dice 102' being placed on semiconductor die locations 102 (FIG. 6) and further levels of singulated semiconductor dice 102' being stacked (FIG. 10) have each been previously thinned and further processed at the wafer level (FIG. 5A) by application of a dielectric material 122 to back side 118, then forming through vias 120 into wafer 100', through vias then being lined with dielectric material 222 and filled with a conductive material to form conductors 124 comprising conductive pillars 126 protruding above back sides 118 to the surface of dielectric material 122. Semiconductor dice 102', with dielectric material 122 and conductive pillars 126 in place, may then be singulated and stacked. Such an embodiment may facilitate more rapid fabrication of the stacks of semiconductor dice 102', increase yield and enable tighter control of bond line width.

[0035] Additional levels of semiconductor dice 102' as shown in FIG. 10 are then stacked at each semiconductor die location 102 of wafer 100, each semiconductor die 102' secured and electrically connected to an underlying semiconductor die 102' as described above with respect to FIGS. 6 through 9 and configured with through vias 120 and conductive pillars 126 for connection to terminal pads 108' of another semiconductor die 102' until a desired number of layers of semiconductor dice 102' is formed. The uppermost semiconductor die 102*u*', however, does not require through vias. At that point, and as illustrated in FIG. 10, back sides 118' of uppermost semiconductor dice 102' are covered with dielectric material 122 extending into spaces 130 between adjacent semiconductor dice 102' and over exposed side surfaces 132 thereof.

[0036] Referring now to FIG. 11, the assemblies of stacked semiconductor dice 102' on semiconductor die locations 102 of wafer 100 are partially singulated to a depth into wafer 100, for example, above device layer 104, singulation being effected in first cuts with a dicing saw of a width *W* sized to remove dielectric material 122 or 222 from between adjacent semiconductor dice 102' as well as material from substantially an entirety of each scribe area 112 of mutually

adjacent semiconductor dice **102'** in adjacent stacks of semiconductor dice **102'** and form a larger space **134**.

[0037] As shown in FIG. 12, another dielectric material **322** comprising an environmental coating deposited by, for example, one of the techniques referred to above is effected to prevent moisture penetration into each assembly **200** of multiple semiconductor dice **102'** and a partially singulated semiconductor die location **102**. Dielectric material **322** extends over back sides of the uppermost dice **102'** of each assembly **200**, over sides of the die stacks in contact with material of the semiconductor dice **102'**, and laterally outwardly over exposed surfaces of the partially singulated semiconductor die locations **102**. Suitable dielectric materials may be non-polymeric and formed in situ over assemblies **200**. Such dielectric materials include, for example, a silicon nitride or a silicon oxynitride, applied to form a substantially conformal coating of a thickness of between about 25 μm and about 50 μm . FIG. 15 illustrates the effect of such an applied dielectric material **322** to not only substantially conformally coat exterior surfaces of the die stacks, but also to fill any exposed peripheral spaces **136** between, for example, a semiconductor die **102'** and an adjacent, previously applied dielectric material **122** in the bond line between mutually superimposed semiconductor dice **102'**.

[0038] In FIG. 13, each assembly **200** is then singulated in second, narrower cuts through an entire depth of wafer **100** and into adhesive **116** through a center of each space **134** and using a dicing saw of a width substantially less than the width of spaces **134** to cut gaps **138**, so as to not contact dielectric material **322** of protective coating on side surfaces **132** of semiconductor dice **102'** and completely sever adjacent semiconductor die locations **102** of wafer **100** and singulate assemblies **200**. Each singulated assembly **200** is then removed from carrier substrate **114** by conventional pick-and-place equipment after adherence of adhesive **116** to carrier substrate **114** is substantially compromised by application of an appropriate release agent depending on the nature of adhesive **116** (e.g., a thermal release adhesive, a solvent release adhesive, or an ultraviolet (UV) release adhesive). An individual assembly **200** after package completion is shown in FIG. 14.

[0039] FIG. 16A depicts multiple in-process unsingulated assemblies **200** of heterogeneous semiconductor dice **102'** stacked on semiconductor die locations **102** of a wafer **100** at a stage of fabrication corresponding to that depicted and described with respect to FIG. 10. In FIG. 16A, wafer **100** comprises logic die locations **102i**, upon which DRAM dice **102d'** are stacked, and over which at the top of each stack is an RF die **102r'**.

[0040] FIG. 16B depicts other, singulated assemblies **200** of semiconductor dice **102'** stacked on severed semiconductor die locations **102** of a wafer **100** prior to removal from carrier substrate **114**. In FIG. 16B, wafer **100** comprises DRAM die locations **102d**, multiple DRAM dice **102d'** are stacked on each DRAM die location **102d**, and at the top of each stack is an RF die **102r'**.

[0041] Notably, in each of FIGS. 16A and 16B, the relatively wide scribe area at a periphery of each die location **102** and each die **102'** in a given stack provides wide tolerances for singulation and enables semiconductor dice exhibiting different functionalities to be stacked into an assembly of controlled die width, which may then be fabricated into a cube with mutually parallel, aligned die sides,

facilitating environmental protection with a post-assembly applied coating of the types disclosed. A conventional requirement for encapsulation of the assemblies with a molding compound is also eliminated. In addition, loss of wafer material may be minimized by close spacing of adjacent die stacks, enabled by use of the disclosed dielectric materials, and heights of the die stacks may be substantially reduced by use of the disclosed dielectric materials in the bond line in lieu of conventional dielectrics such as non-conductive pastes, non-conductive films and capillary underfills. Finally, the noted elimination of a requirement for encapsulation of the assemblies with a conventional molding compound significantly reduces the footprint, and thus the real estate required by the package on higher-level packaging.

[0042] Semiconductor devices (e.g., the packaged semiconductor device assemblies **200**) in accordance with embodiments of the disclosure may be used in embodiments of electronic systems of the disclosure. For example, FIG. 17 is a block diagram of an illustrative electronic system **300** according to embodiments of disclosure. The electronic system **300** may comprise, for example, a computer or computer hardware component, a server or other networking hardware component, a cellular telephone, a digital camera, a personal digital assistant (PDA), portable media (e.g., music) player, a Wi-Fi or cellular-enabled tablet such as, for example, an iPad® or SURFACE® tablet, an electronic book, a navigation device, etc. The electronic system **300** includes at least one memory device **302**. The memory device **302** may include, for example, an embodiment of a semiconductor device assembly **200** described herein. Such memory device may, optionally, include dice configured for other functions such as, for example, a logic die, an RF die, or both. The electronic system **300** may further include at least one electronic signal processor device **304** (often referred to as a "microprocessor"). The electronic system **300** may further include one or more input devices **306** for inputting information into the electronic system **300** by a user, such as, for example, a mouse or other pointing device, a keyboard, a touchpad, a button, or a control panel. The electronic system **300** may further include one or more output devices **308** for outputting information (e.g., visual or audio output) to a user such as, for example, a monitor, a display, a printer, an audio output jack, a speaker, etc. In some embodiments, the input device **306** and the output device **308** may comprise a single touchscreen device that can be used both to input information to the electronic system **300** and to output visual information to a user. The input device **306** and the output device **308** may communicate electrically with one or more of the memory device **302** and the electronic signal processor device **304**. It is also contemplated that, in lieu of separate memory and signal processor devices **302** and **304**, a single assembly **200** may be configured as a system in a package including a processor and/or other die functionalities as noted previously.

[0043] In an embodiment, a method for fabricating a semiconductor device package comprises adhering a wafer comprising laterally spaced semiconductor die locations thereof to a carrier substrate with an active surface of the wafer facing the carrier substrate, forming a dielectric material over a back side of the wafer, placing a first level of singulated semiconductor dice in mutually laterally spaced relationship over respective semiconductor die locations and connecting conductive pillars protruding from the back side

of the wafer through the dielectric material to aligned terminal pads of the semiconductor dice.

[0044] In another embodiment, a method of forming a semiconductor device package comprises stacking multiple levels of singulated semiconductor dice in mutually laterally spaced relationship over respective semiconductor die locations on a back side of a wafer, and before stacking each singulated semiconductor die, forming a dielectric bond line material over a back side of a semiconductor die location or a lower singulated semiconductor die. Terminal pads of singulated dice are connected to conductive pillars exposed through the dielectric bond line material over the back sides of the semiconductor die locations or over back sides of a lower level of singulated semiconductor dice, cuts of a first width are made into spaces between the singulated semiconductor dice, into material in scribe areas thereof and into material of the wafer within scribe areas between semiconductor die locations. A coating is formed over back sides of uppermost dice of the stacks, over sides of the singulated semiconductor dice and over material of the wafer between semiconductor die locations and cuts of a second, narrower width are made between the stacks into and through remaining material of the wafer between the semiconductor die locations.

[0045] In a further embodiment, a semiconductor device package comprises a stack of semiconductor dice, wherein a surface of a lowermost semiconductor die of the stack protrudes laterally beyond a periphery of other, higher semiconductor dice of the stack, a non-polymeric dielectric bond line material between adjacent semiconductor dice of the stack, connections between metal pillars and aligned terminal pads of adjacent semiconductor dice of the stack, the connections comprising diffusion bonds or mutual contact secured by dielectric bonding of the semiconductor dice with the dielectric bond line material and a substantially conformal, non-polymeric coating extending over a back side of an uppermost semiconductor die of the stack, over and in contact with material of the semiconductor dice on sides of the stack and over and in contact with the laterally protruding surface of the lowermost semiconductor die of the stack.

[0046] In yet another embodiment, an electronic system comprises at least one input device, at least one output device, a processor device operably coupled to the at least one input device and the at least one output device and a memory device. The memory device comprises a stack of semiconductor dice, wherein a lowermost semiconductor die of the stack protrudes laterally beyond a periphery of other, higher semiconductor dice of the stack, a dielectric bond line material comprising an in situ formed compound between adjacent semiconductor dice of the stack, and connections between metal pillars and aligned terminal pads of adjacent semiconductor dice of the stack, the connections comprising diffusion bonds or mutual contact secured by dielectric bonding of the semiconductor dice. A substantially conformal coating comprising an in situ formed compound extends over a back side of an uppermost semiconductor die of the stack, over and in contact with material of the semiconductor dice on sides of the stack and over and in contact with the laterally protruding lowermost semiconductor die of the stack.

[0047] While certain illustrative embodiments have been described in connection with the figures, those of ordinary skill in the art will recognize and appreciate that embodi-

ments encompassed by the disclosure are not limited to those embodiments explicitly shown and described herein. Rather, many additions, deletions, and modifications to the embodiments described herein may be made without departing from the scope of embodiments encompassed by the disclosure, such as those hereinafter claimed, including legal equivalents. In addition, features from one disclosed embodiment may be combined with features of another disclosed embodiment while still being encompassed within the scope of the disclosure.

What is claimed is:

1. A semiconductor device package, comprising:
 - a stack of semiconductor dice;
 - non-polymeric dielectric bonds between adjacent semiconductor dice of the stack;
 - connections between metal pillars and aligned terminal pads of adjacent semiconductor dice of the stack, the connections comprising at least one of diffusion bonds or mutual contact secured by the dielectric bonds; and
 - a non-polymeric coating extending over a back side of an uppermost semiconductor die of the stack, over and in contact with sides of the semiconductor dice of the stack.
2. The semiconductor device package of claim 1, further comprising conductive elements on a surface of the lowermost semiconductor die opposite other semiconductor dice of the stack.
3. The semiconductor device package of claim 1, wherein the non-polymeric coating extends into openings in sides of the stack between material of the non-polymeric dielectric bonds and material of adjacent semiconductor dice.
4. The semiconductor device package of claim 1, wherein material of the non-polymeric dielectric bonds and material of the non-polymeric coating each comprise an in situ formed compound.
5. The semiconductor device package of claim 4, wherein the compounds are selected from a group consisting of a silicon oxide, a silicon nitride, a silicon oxynitride, a TEOS oxide or an O₃/TEOS oxide.
6. The semiconductor device package of claim 1, wherein at least the material of the non-polymeric dielectric bonds is devoid of filler material.
7. The semiconductor device package of claim 1, wherein a thickness of the non-polymeric dielectric bonds are between about 10 μm and about 25 μm.
8. The semiconductor device package of claim 1, wherein a thickness of the non-polymeric coating is between about 25 μm and about 50 μm.
9. The semiconductor device package of claim 1, wherein material of the non-polymeric dielectric bonds differs from material of the non-polymeric coating.
10. The semiconductor device package of claim 1, wherein at least some of the semiconductor dice of the stack are of a thickness between about 30 μm and about 70 μm.
11. The semiconductor device package of claim 1, wherein one or more semiconductor dice of the stack exhibits a functionality other than memory.
12. The semiconductor device package of claim 11, wherein the one or more other semiconductor dice of the stack exhibits a functionality comprising logic, processor or radiofrequency.

13. A semiconductor device package, comprising:
stacked semiconductor dice;
a non-polymeric dielectric material devoid of filler material bonding adjacent semiconductor dice;
electrical connections extending through the non-polymeric dielectric material between adjacent semiconductor dice; and
a non-polymeric coating extending at least over sides of the semiconductor dice.

14. The semiconductor device package of claim **13**, wherein the non-polymeric dielectric material comprises silicon.

15. The semiconductor device package of claim **13**, wherein the non-polymeric coating comprises silicon.

16. The semiconductor device package of claim **13**, wherein the non-polymeric coating extends into openings between sides of adjacent semiconductor dice.

17. The semiconductor device package of claim **13**, wherein a top surface of an uppermost stacked semiconductor die is covered with non-polymeric dielectric material devoid of filler material.

18. The semiconductor device package of claim **17**, wherein the non-polymeric coating extends over the non-polymeric dielectric material devoid of filler material on the top surface of the uppermost stacked semiconductor die.

19. The semiconductor device package of claim **13**, wherein the non-polymeric coating is substantially conformal.

20. The semiconductor device package of claim **13**, wherein the non-polymeric dielectric material is different than the non-polymeric coating.

21. The semiconductor device package of claim **13**, wherein a thickness of the non-polymeric dielectric material bonding adjacent semiconductor dice is between about 10 μm and about 25 μm and the semiconductor dice are each of a thickness between about 30 μm and about 70 μm .

22. The semiconductor device package of claim **21**, wherein a thickness of the non-polymeric coating is between about 25 μm and about 50 μm .

* * * * *