



US 20200264321A1

(19) **United States**

(12) **Patent Application Publication**
CAO et al.

(10) **Pub. No.: US 2020/0264321 A1**

(43) **Pub. Date: Aug. 20, 2020**

(54) **PACKAGING OF SEMICONDUCTOR X-RAY
DETECTORS**

H01J 37/295 (2006.01)

G01T 1/164 (2006.01)

G01T 1/24 (2006.01)

(71) Applicant: **SHENZHEN XPECTVISION
TECHNOLOGY CO., LTD.**, Shenzhen
(CN)

(52) **U.S. Cl.**
CPC *G01T 1/2018* (2013.01); *H05K 1/0274*
(2013.01); *H01J 2237/26* (2013.01); *G01T*
1/1645 (2013.01); *G01T 1/242* (2013.01);
H01J 37/295 (2013.01)

(72) Inventors: **Peiyan CAO**, Shenzhen (CN); **Yurun
LIU**, Shenzhen (CN)

(21) Appl. No.: **16/867,087**

(22) Filed: **May 5, 2020**

(57) **ABSTRACT**

Related U.S. Application Data

(63) Continuation of application No. 16/170,518, filed on
Oct. 25, 2018, now Pat. No. 10,677,940, which is a
continuation of application No. PCT/CN2016/
099808, filed on Sep. 23, 2016.

Disclosed herein is an image sensor comprising: a plurality
of packages arranged in a plurality of layers; wherein each
of the packages comprises an X-ray detector mounted on a
printed circuit board (PCB); wherein the packages are
mounted on one or more system PCBs; wherein within an
area encompassing a plurality of the X-ray detectors in the
plurality of packages, a dead zone of the packages in each
of the plurality of layers is shadowed by the packages in the
other layers.

Publication Classification

(51) **Int. Cl.**
G01T 1/20 (2006.01)
H05K 1/02 (2006.01)

100

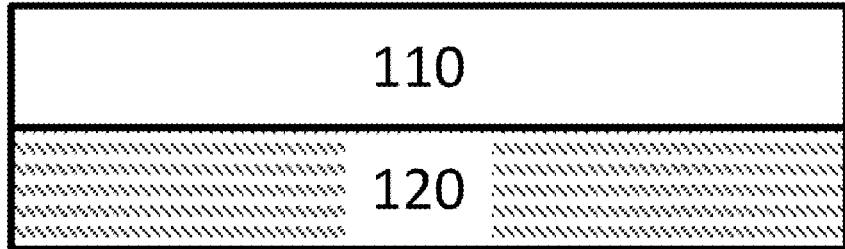

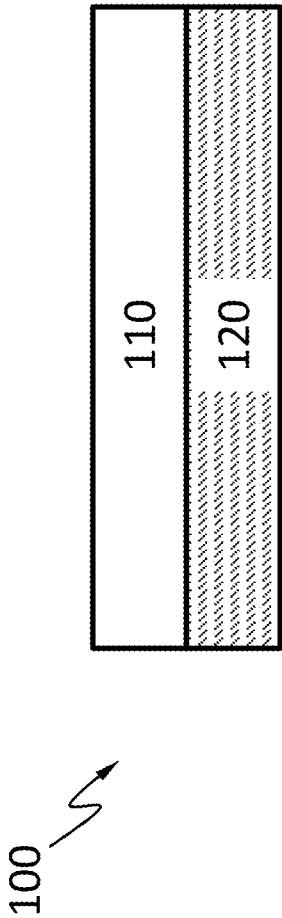

Fig. 1A

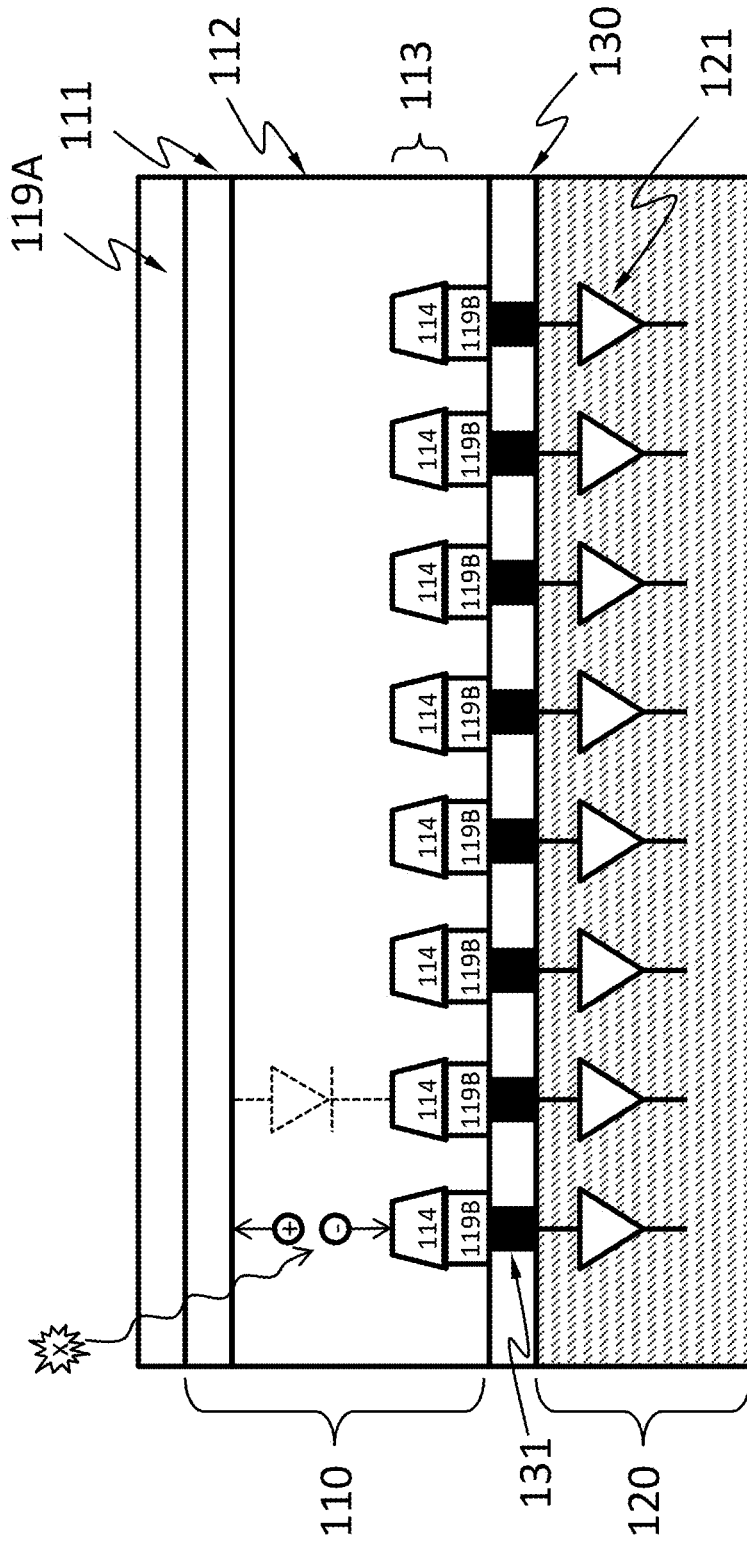

Fig. 1B

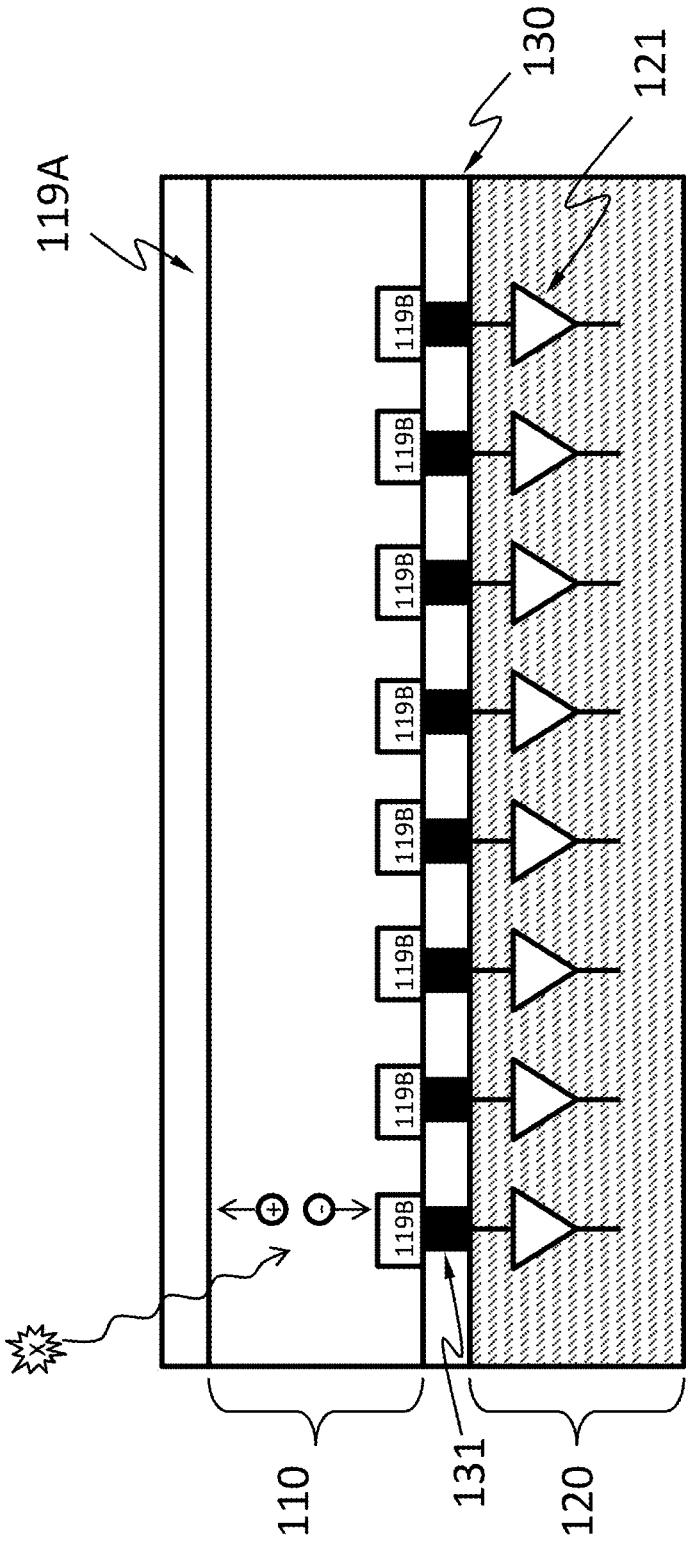

Fig. 1C

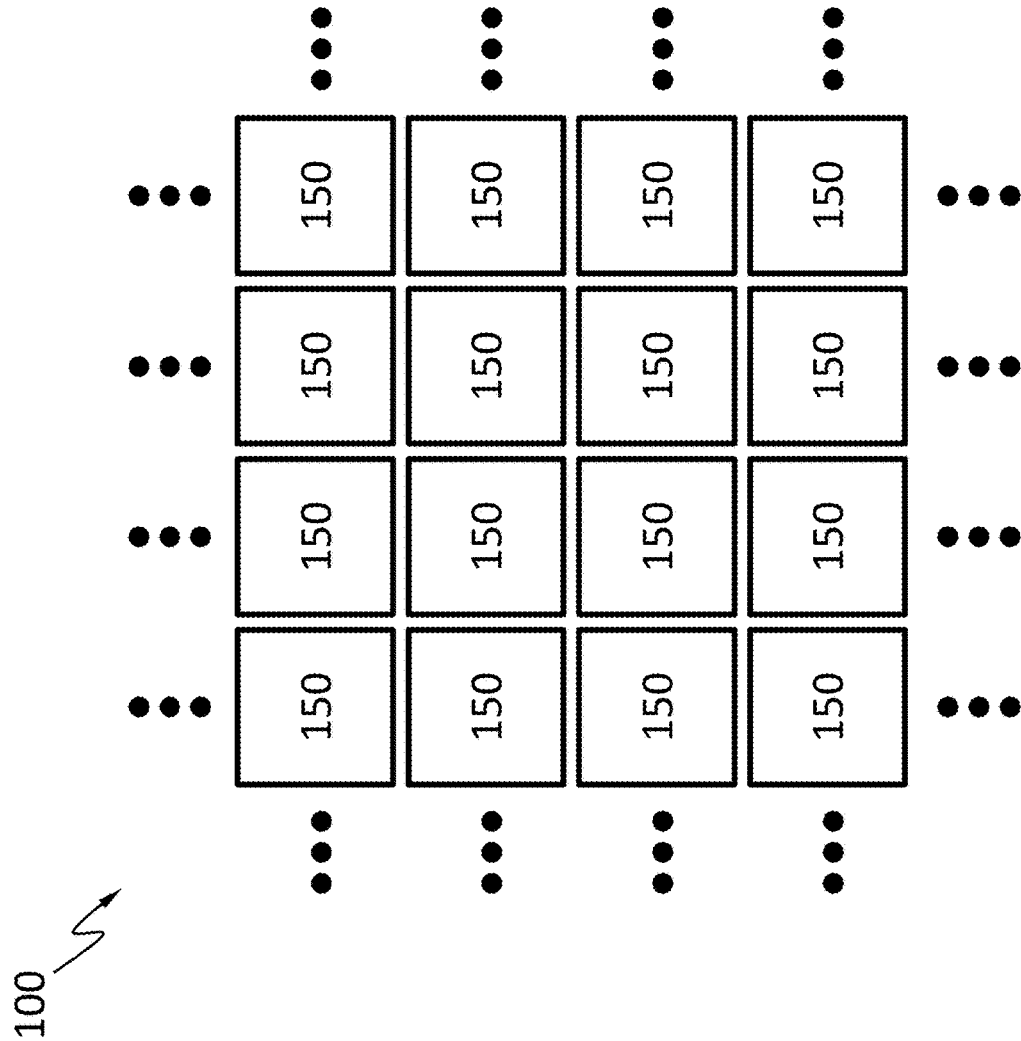

Fig. 2

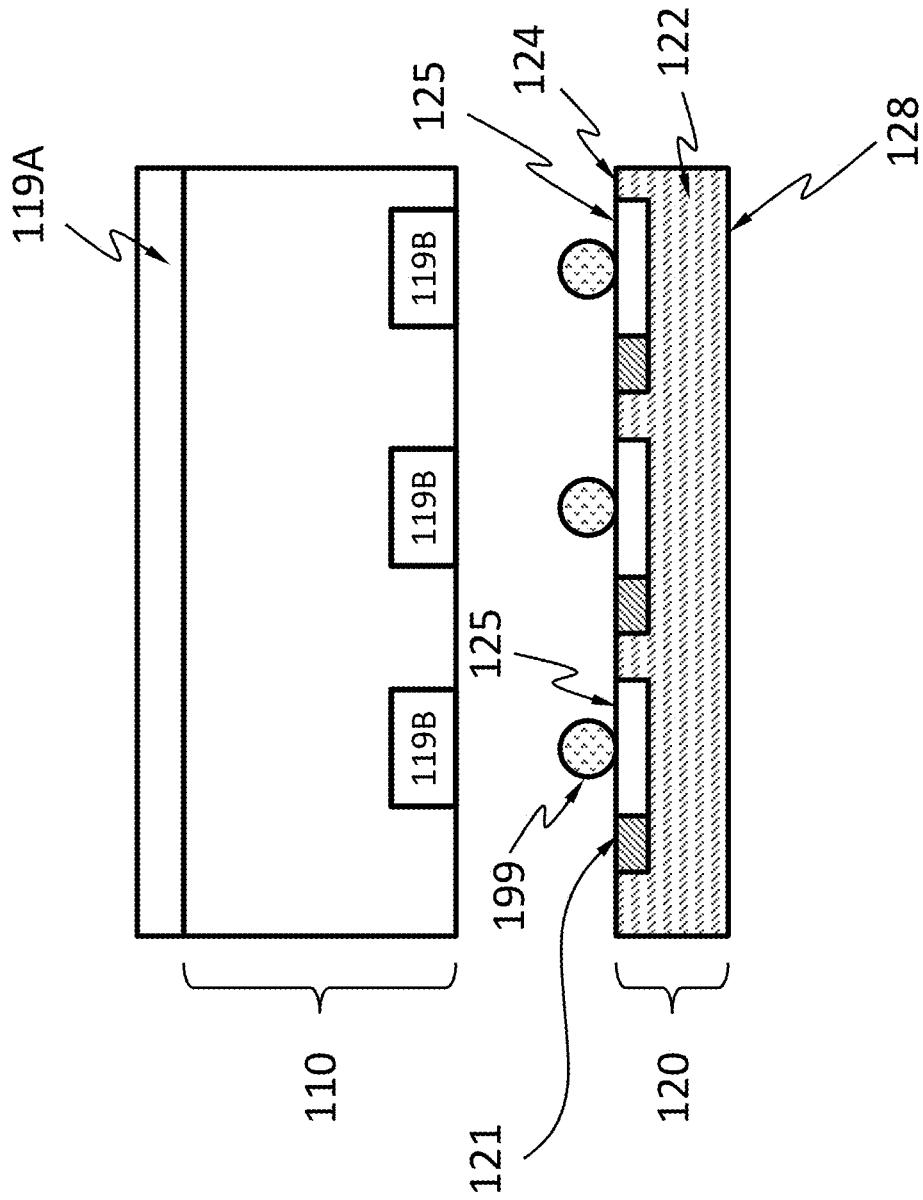

Fig. 3

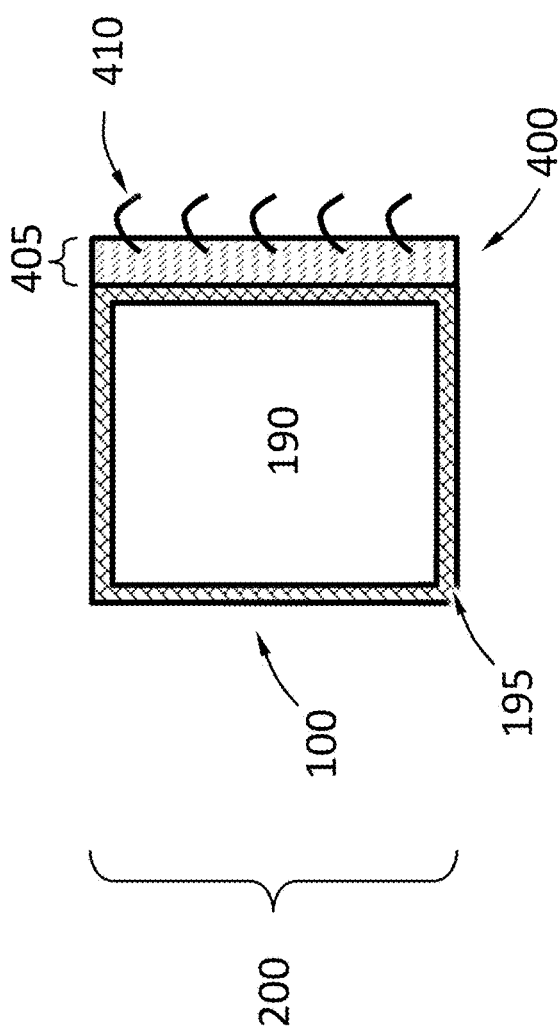

Fig. 4A

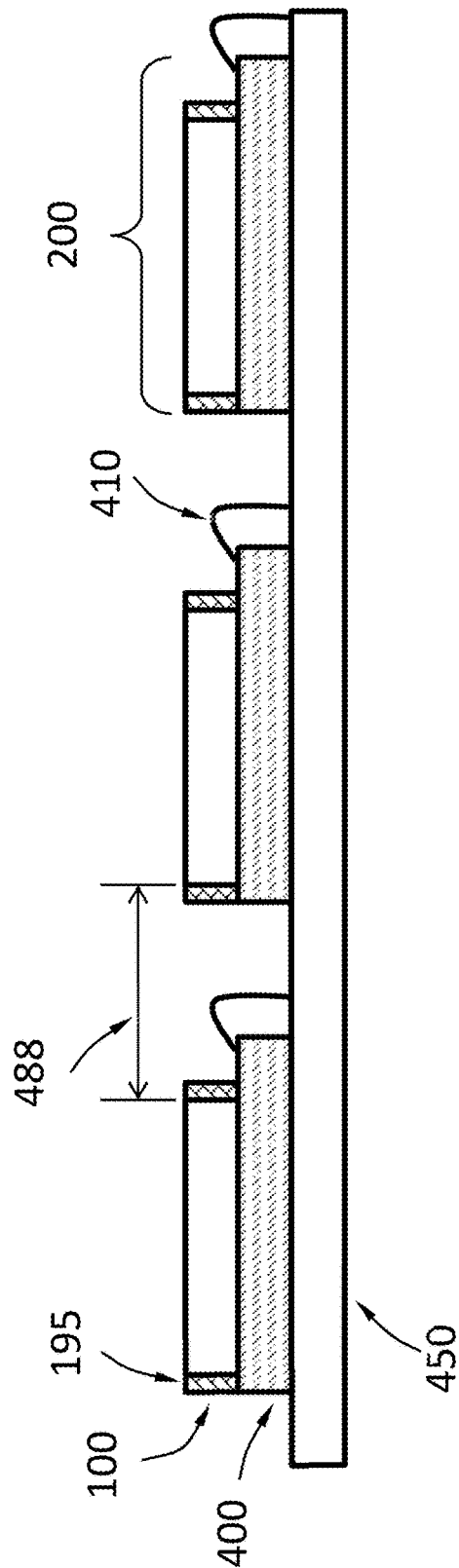

Fig. 4B

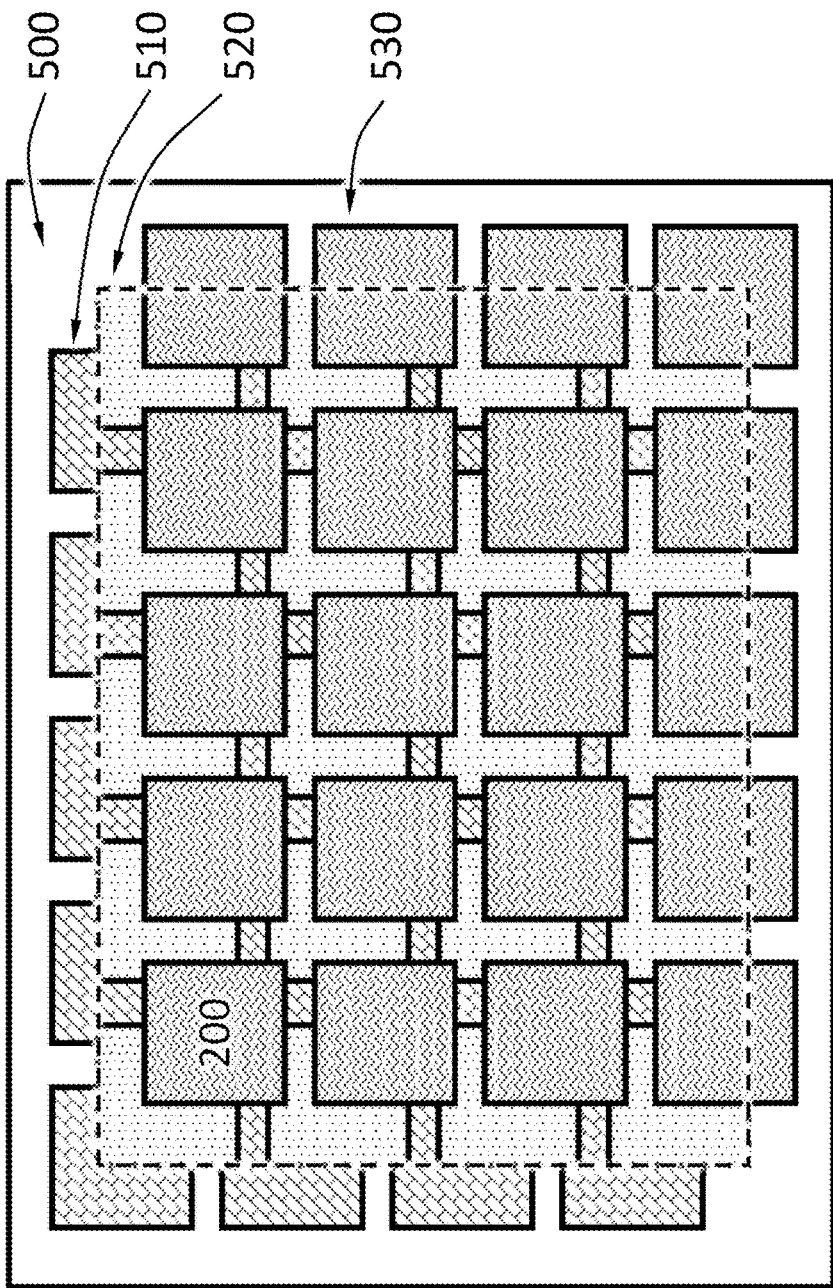

Fig. 5A

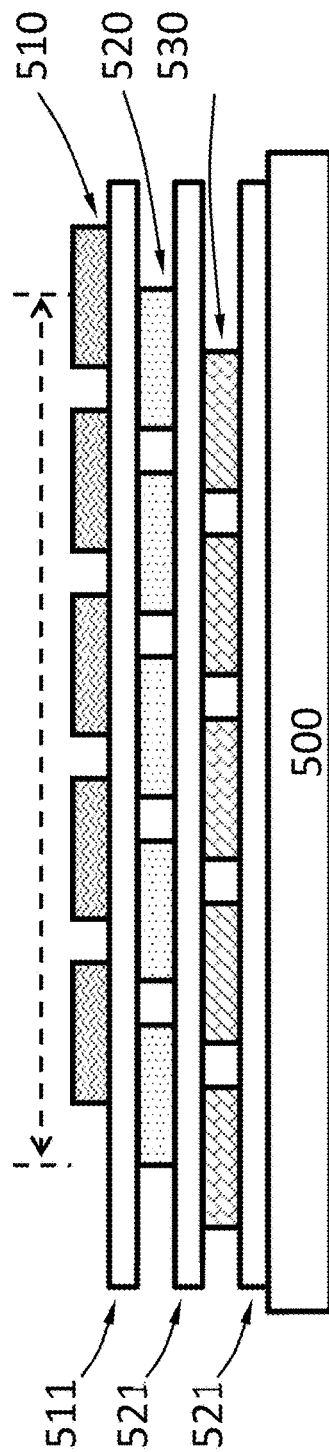

Fig. 5B

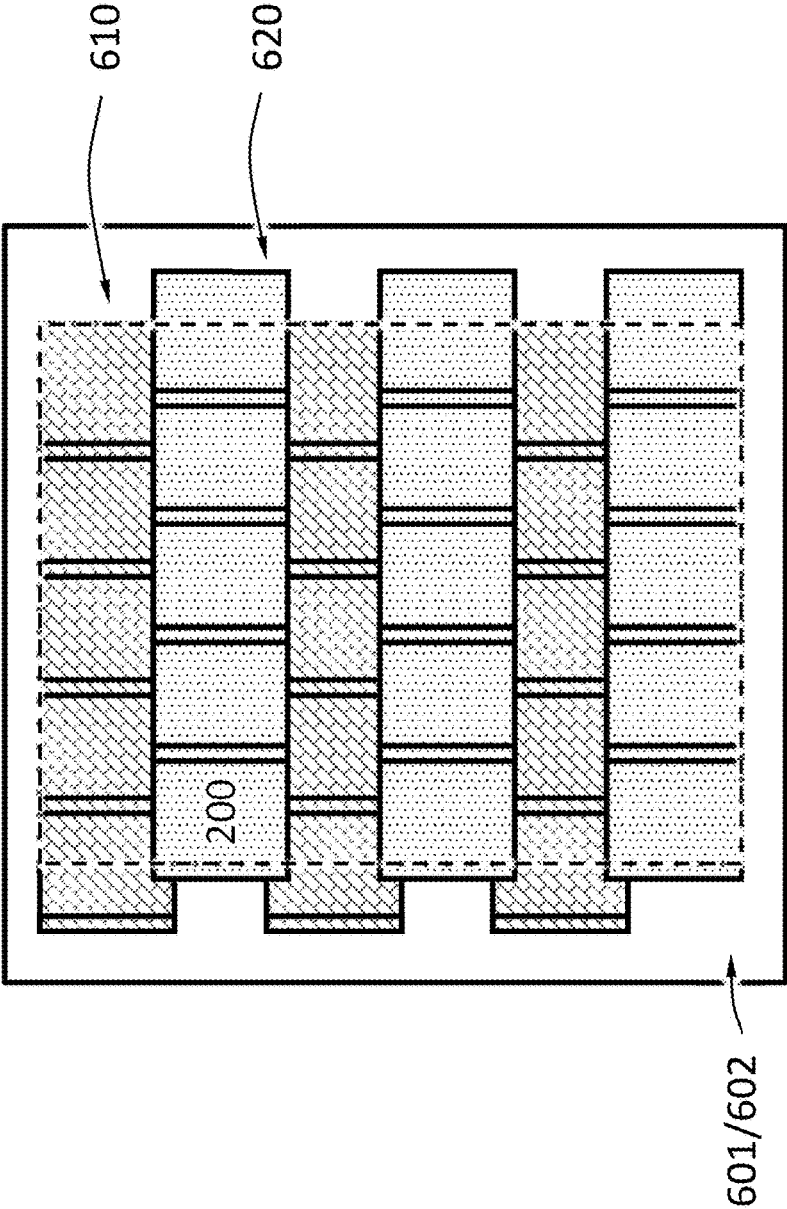

Fig. 6A

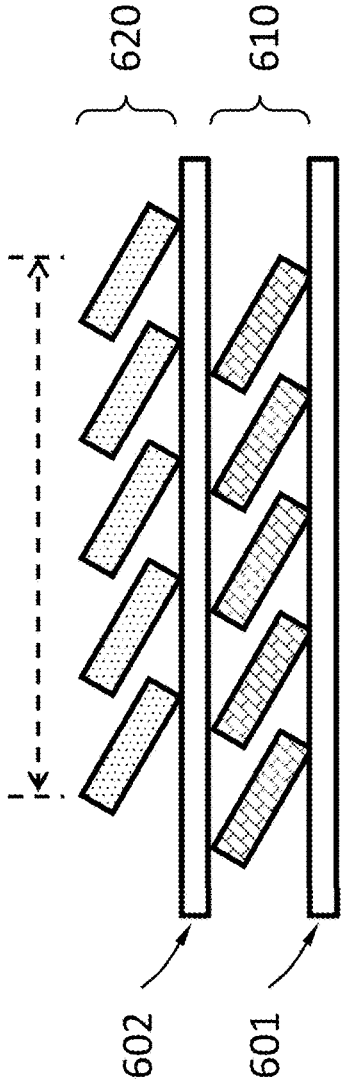

Fig. 6B

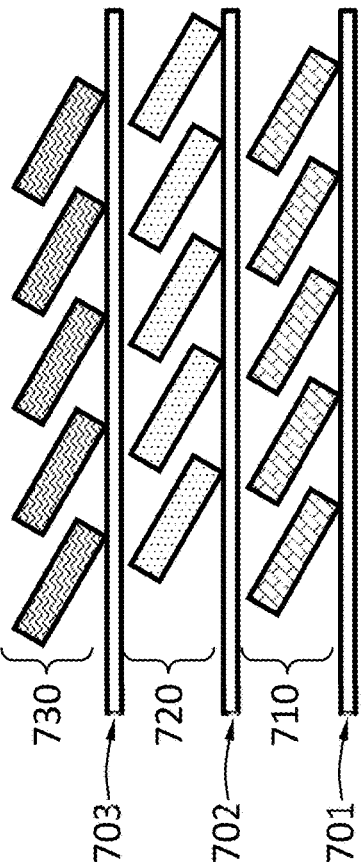
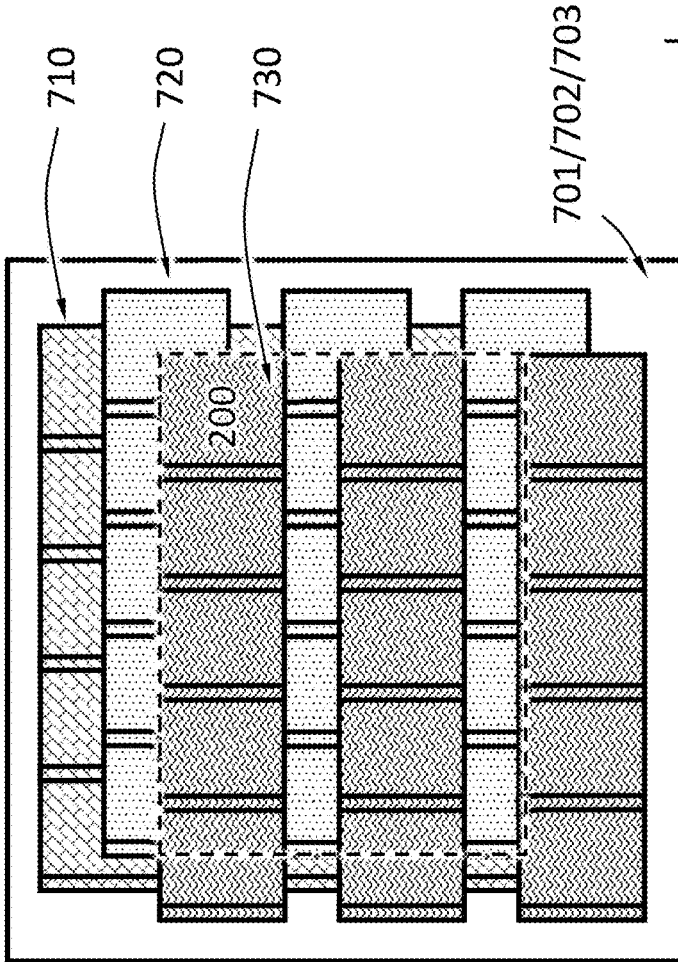

Fig. 7A

Fig. 7B

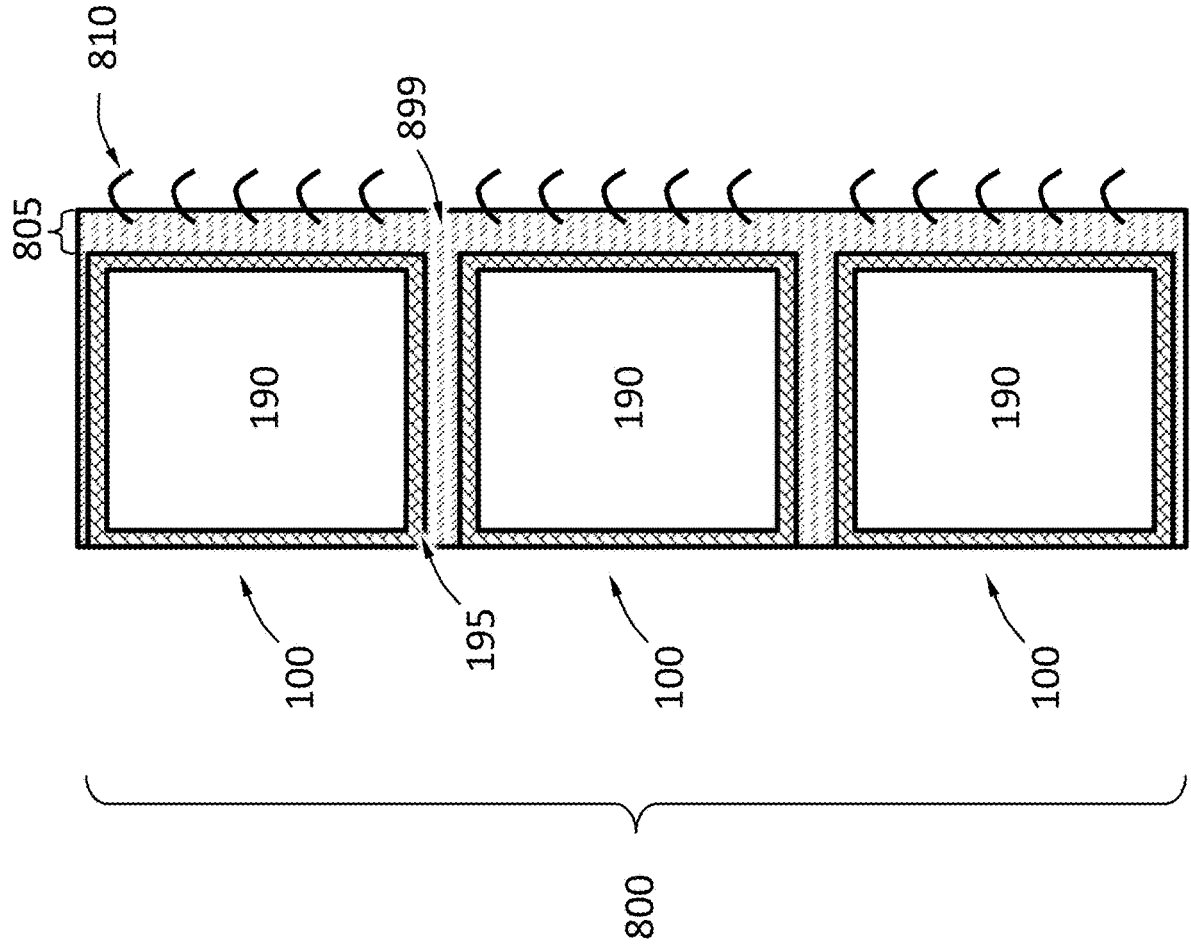

Fig. 8A

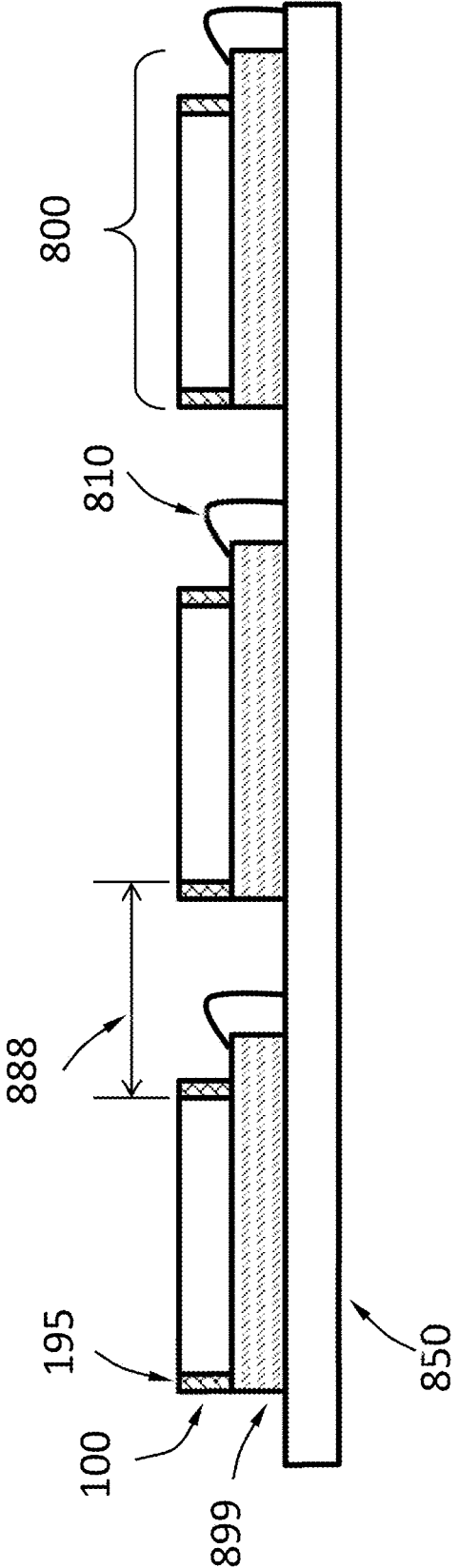

Fig. 8B

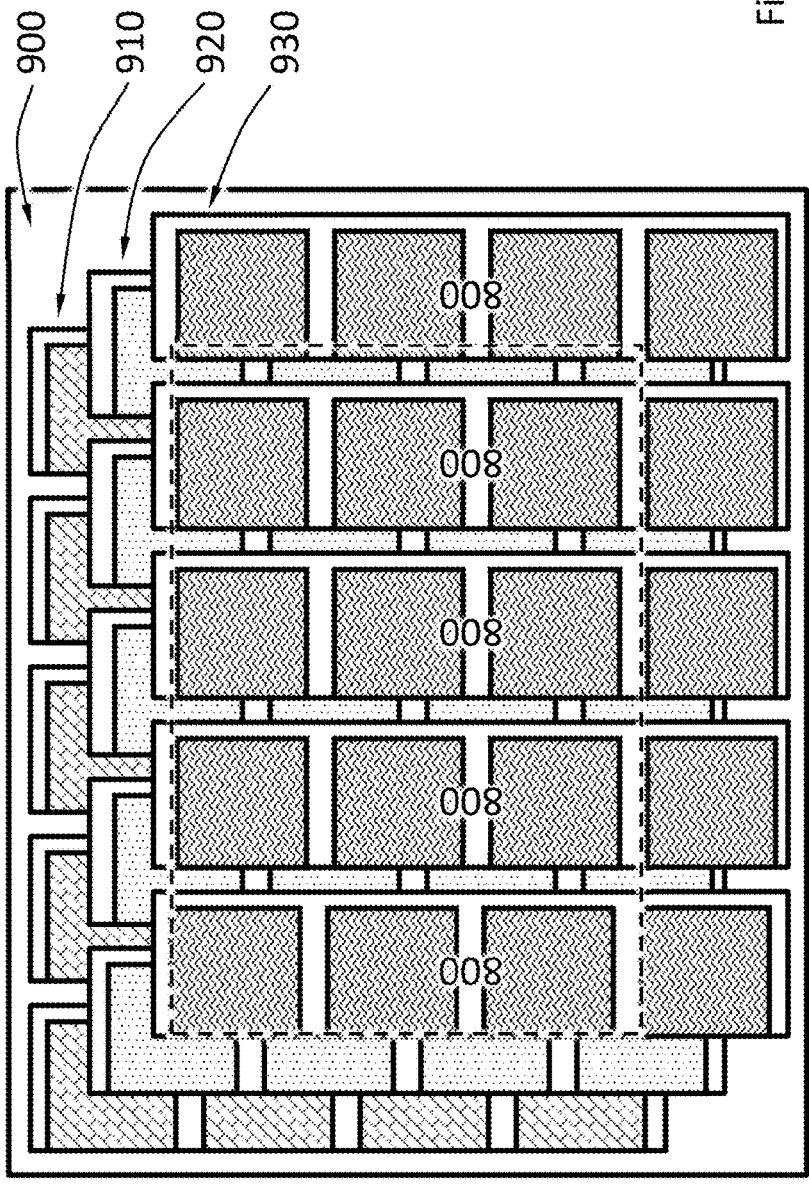

Fig. 9A

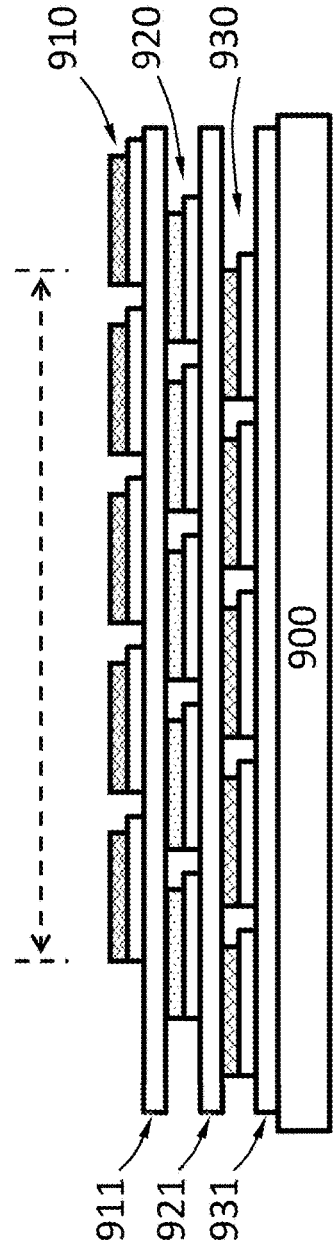

Fig. 9B

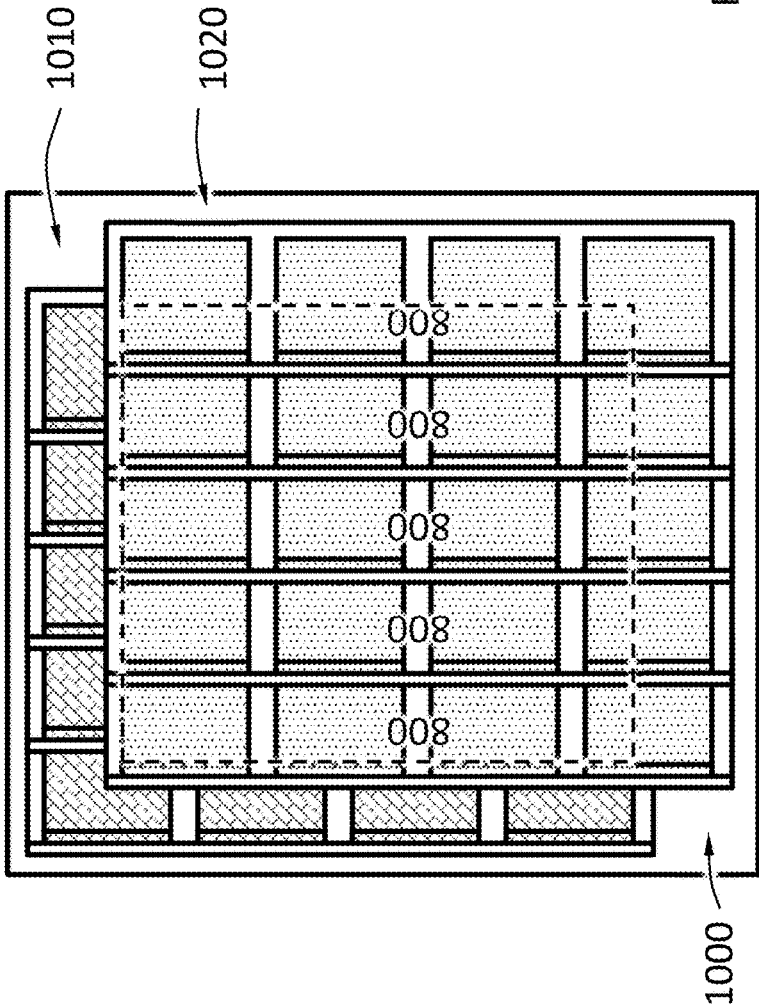

Fig. 10A

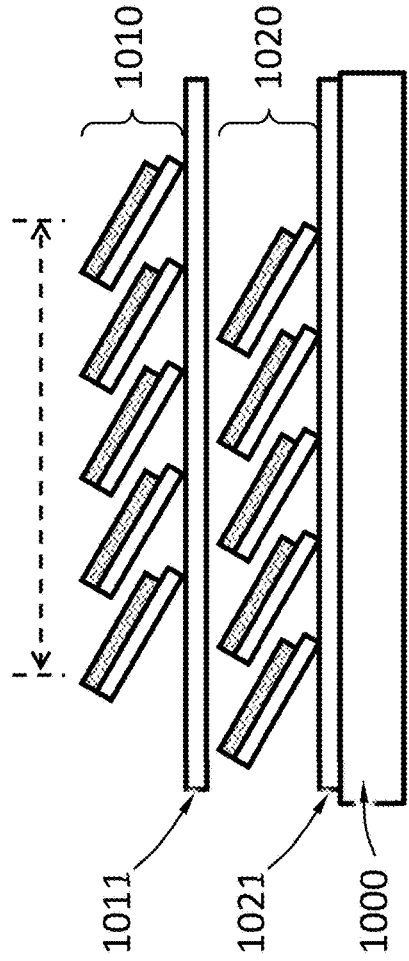

Fig. 10B

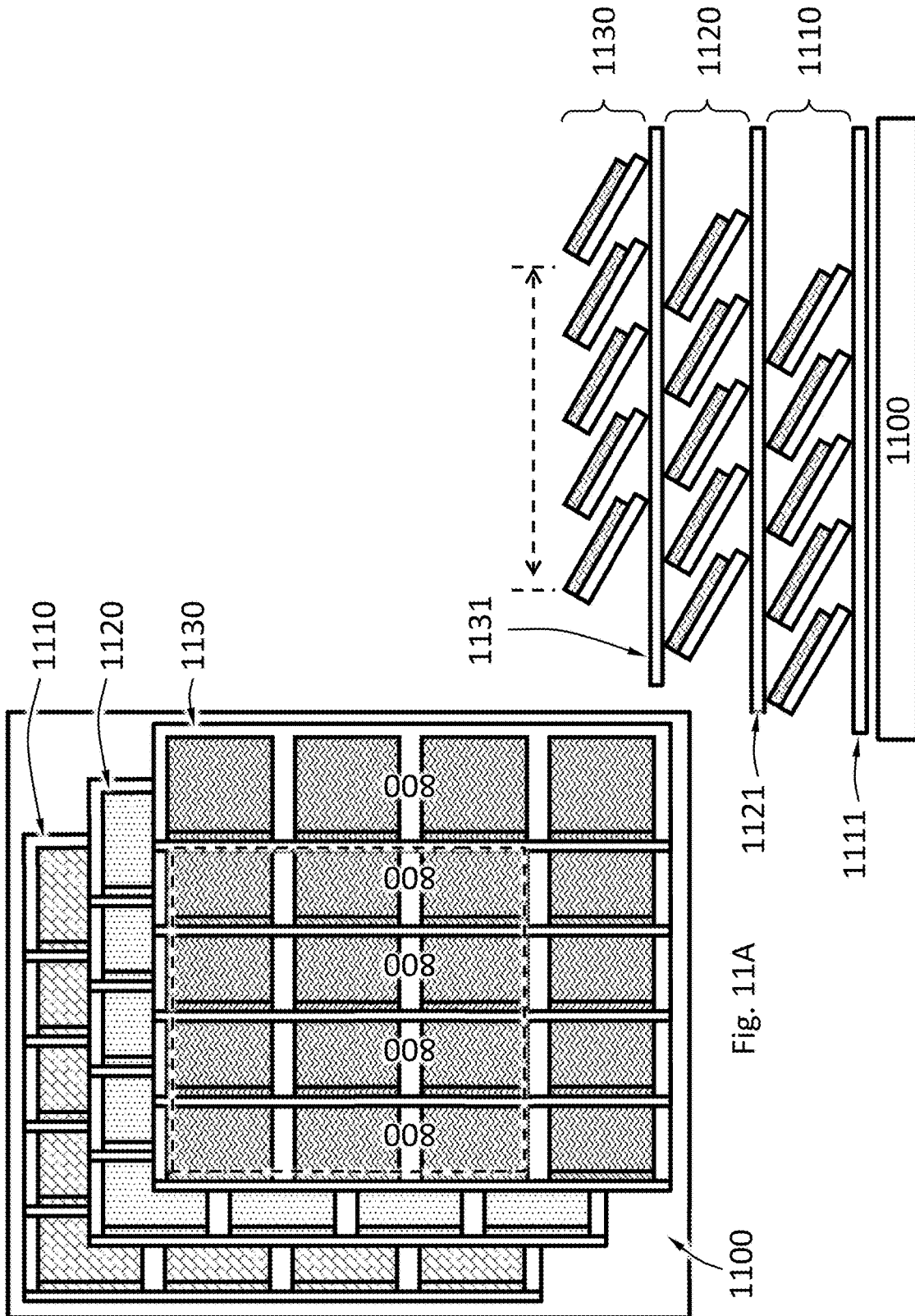

Fig. 11A

Fig. 11B

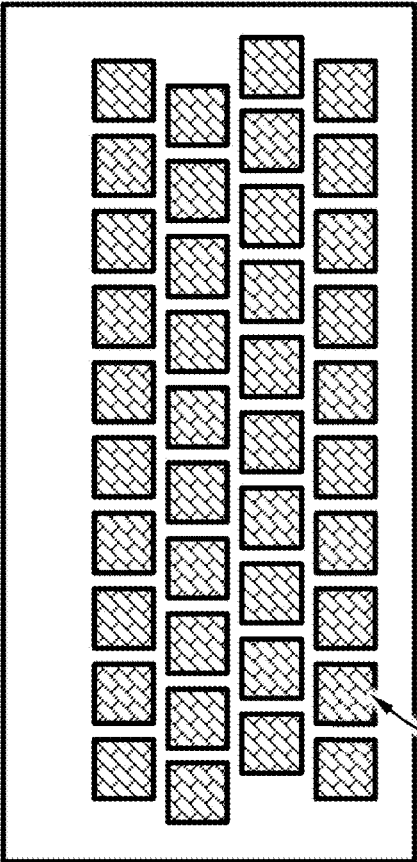
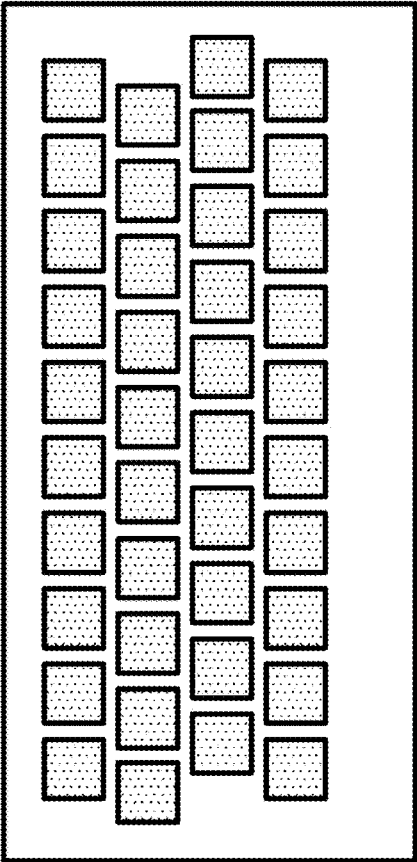
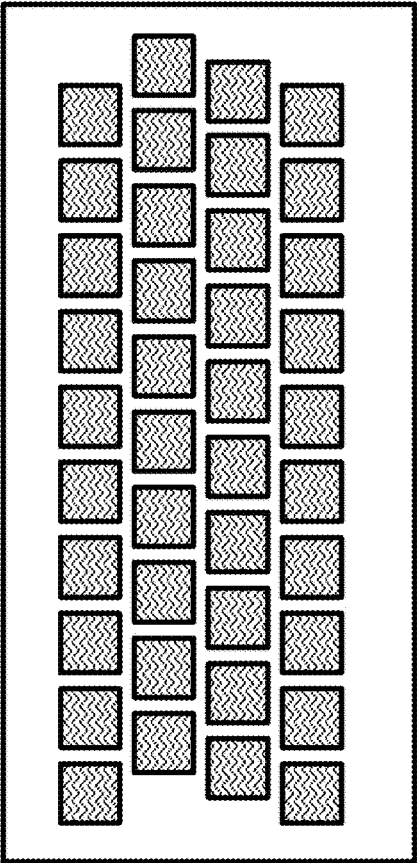
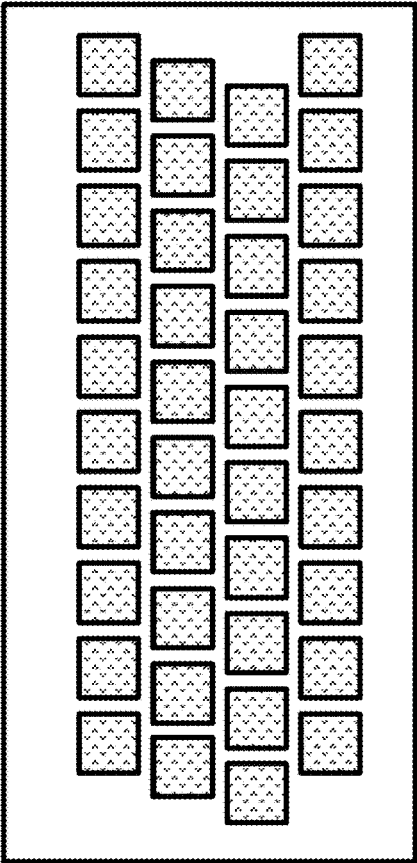

Fig. 12A

100

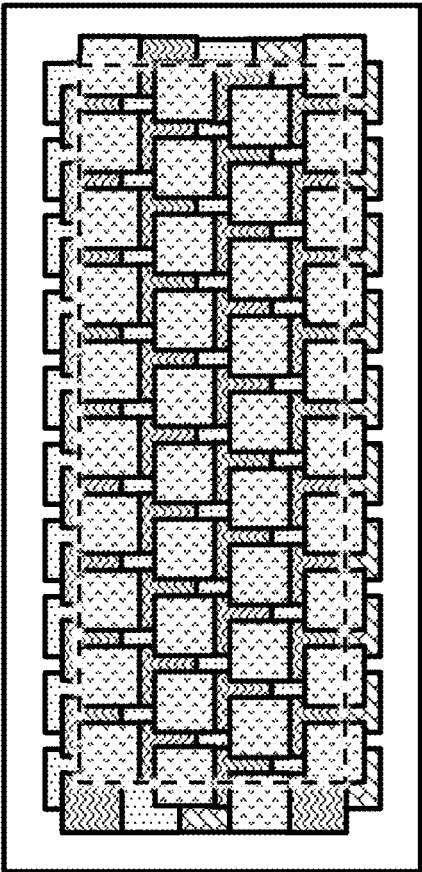

Fig. 12B

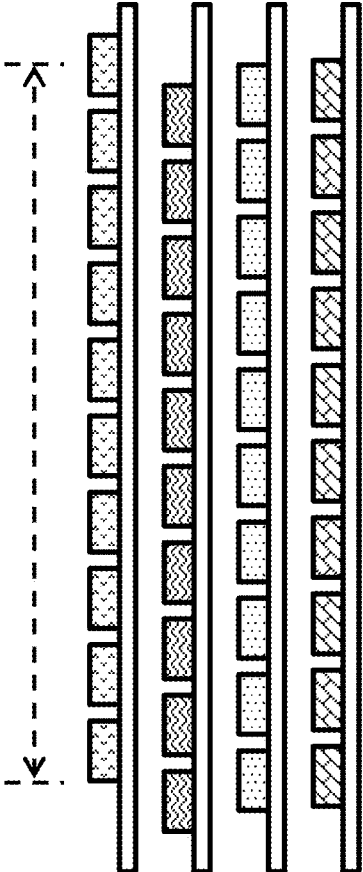
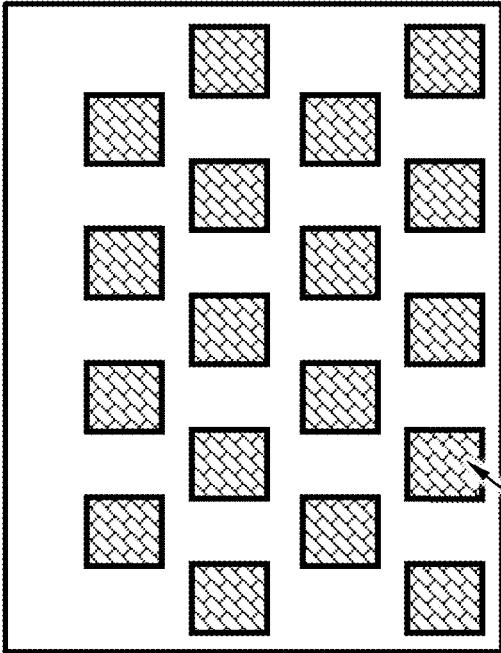
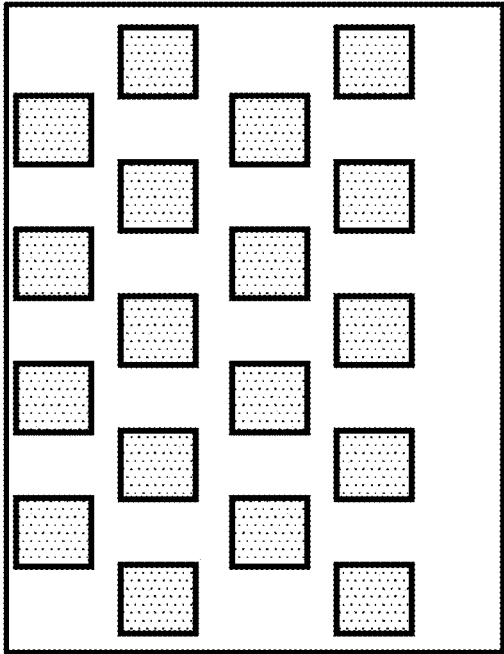
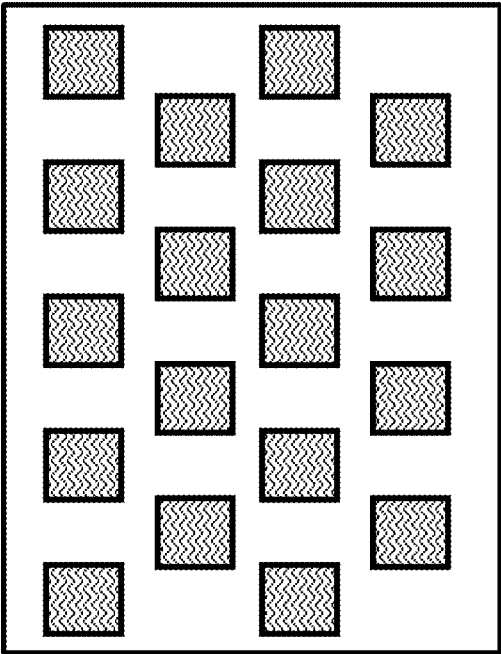

Fig. 12C



100

Fig. 13A

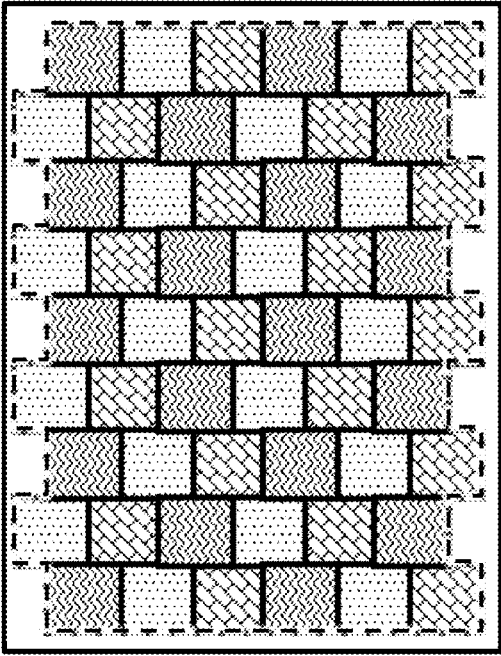

Fig. 13B

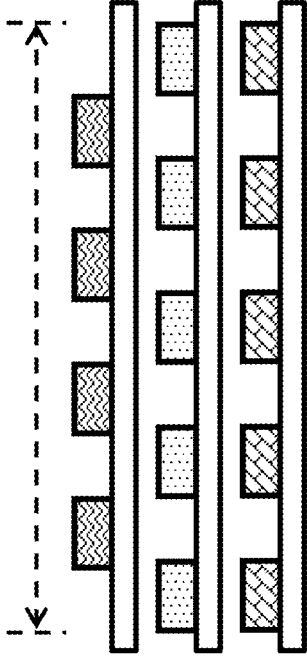
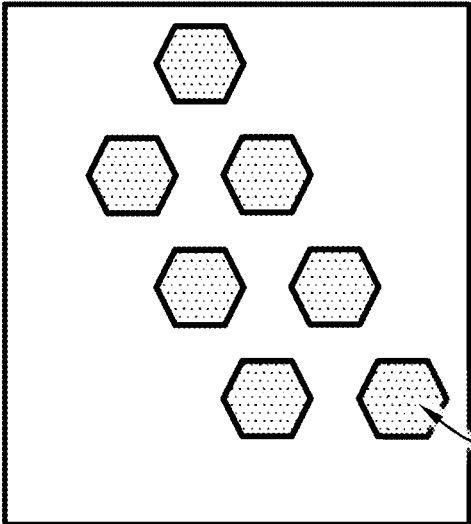
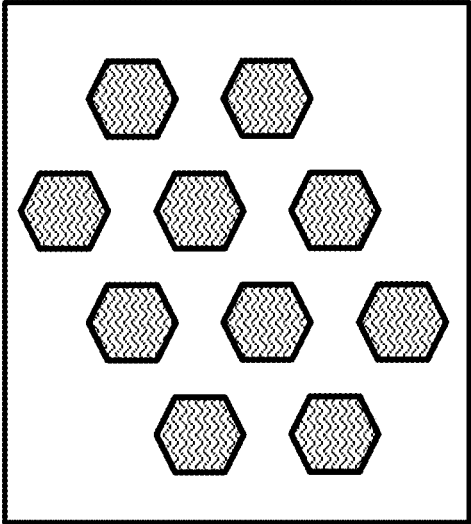

Fig. 13C



100

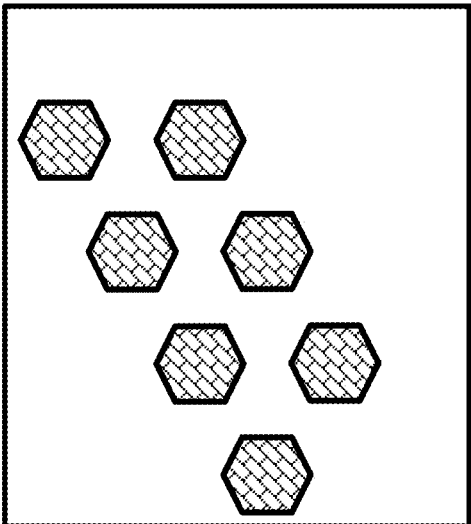

Fig. 14A

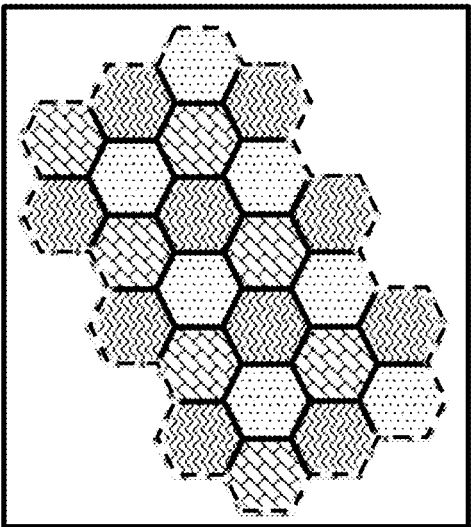

Fig. 14B

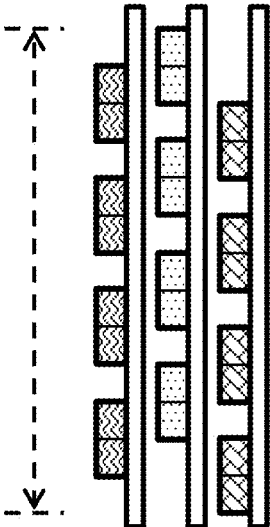

Fig. 14C

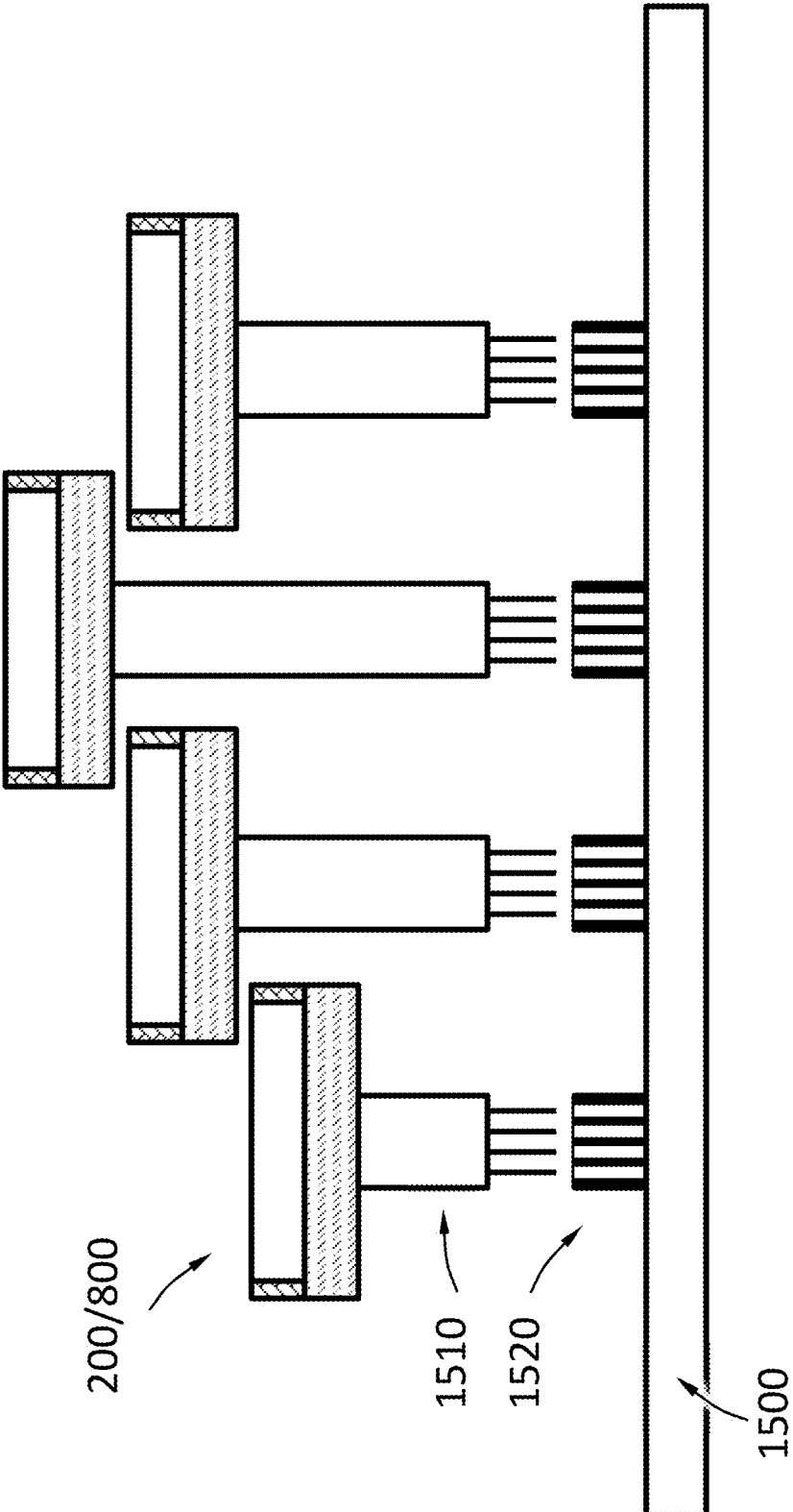

Fig. 15A

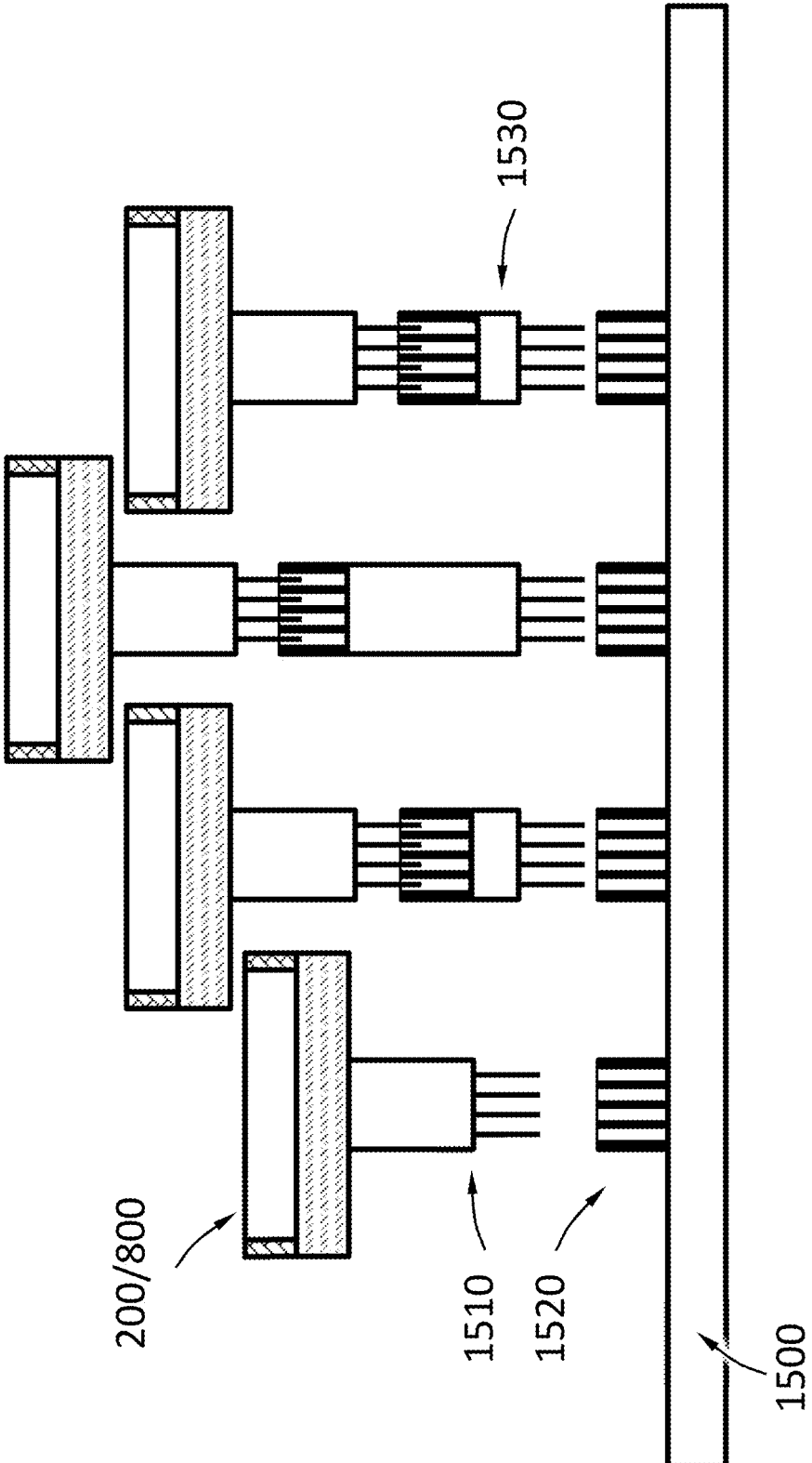

Fig. 15B

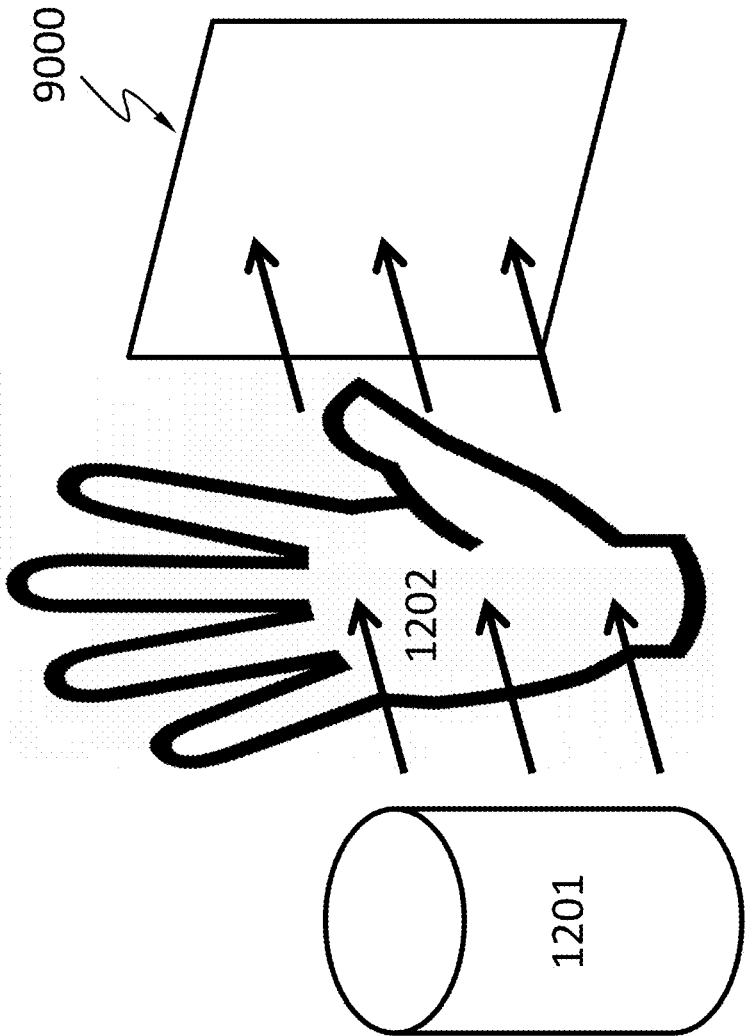

Fig. 16

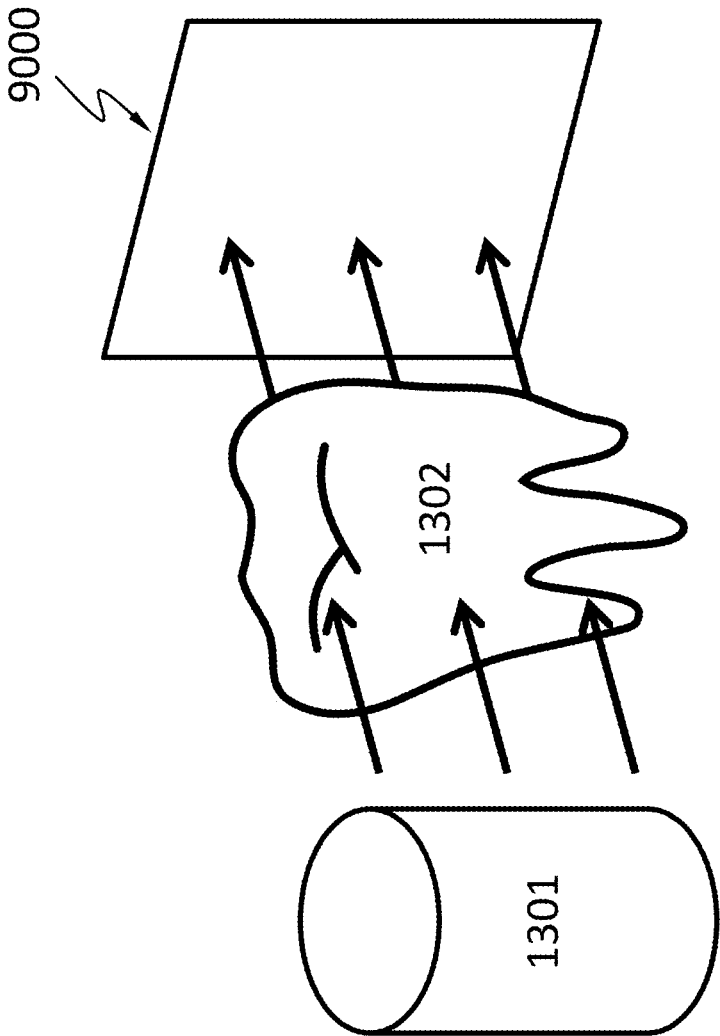

Fig. 17

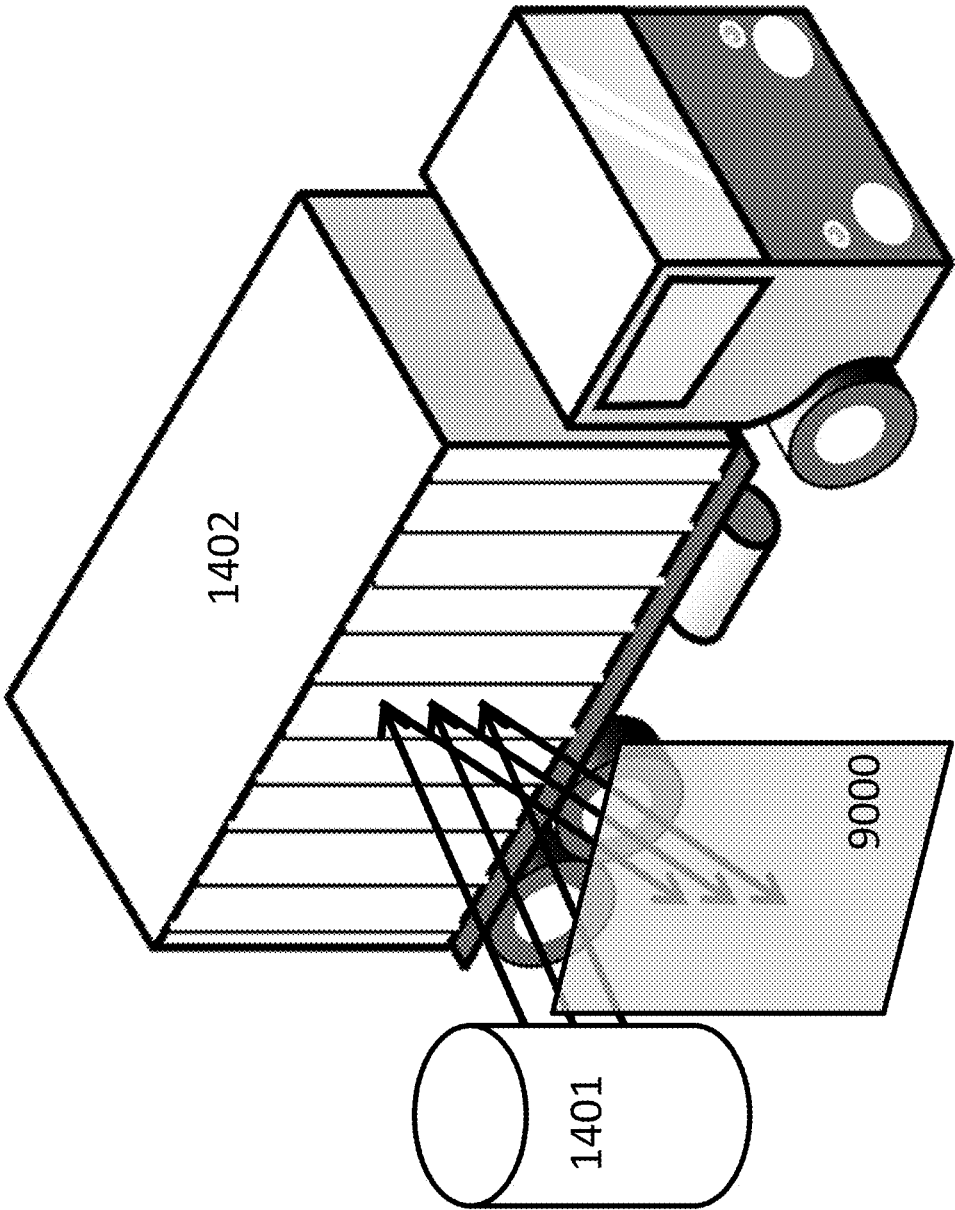

Fig. 18

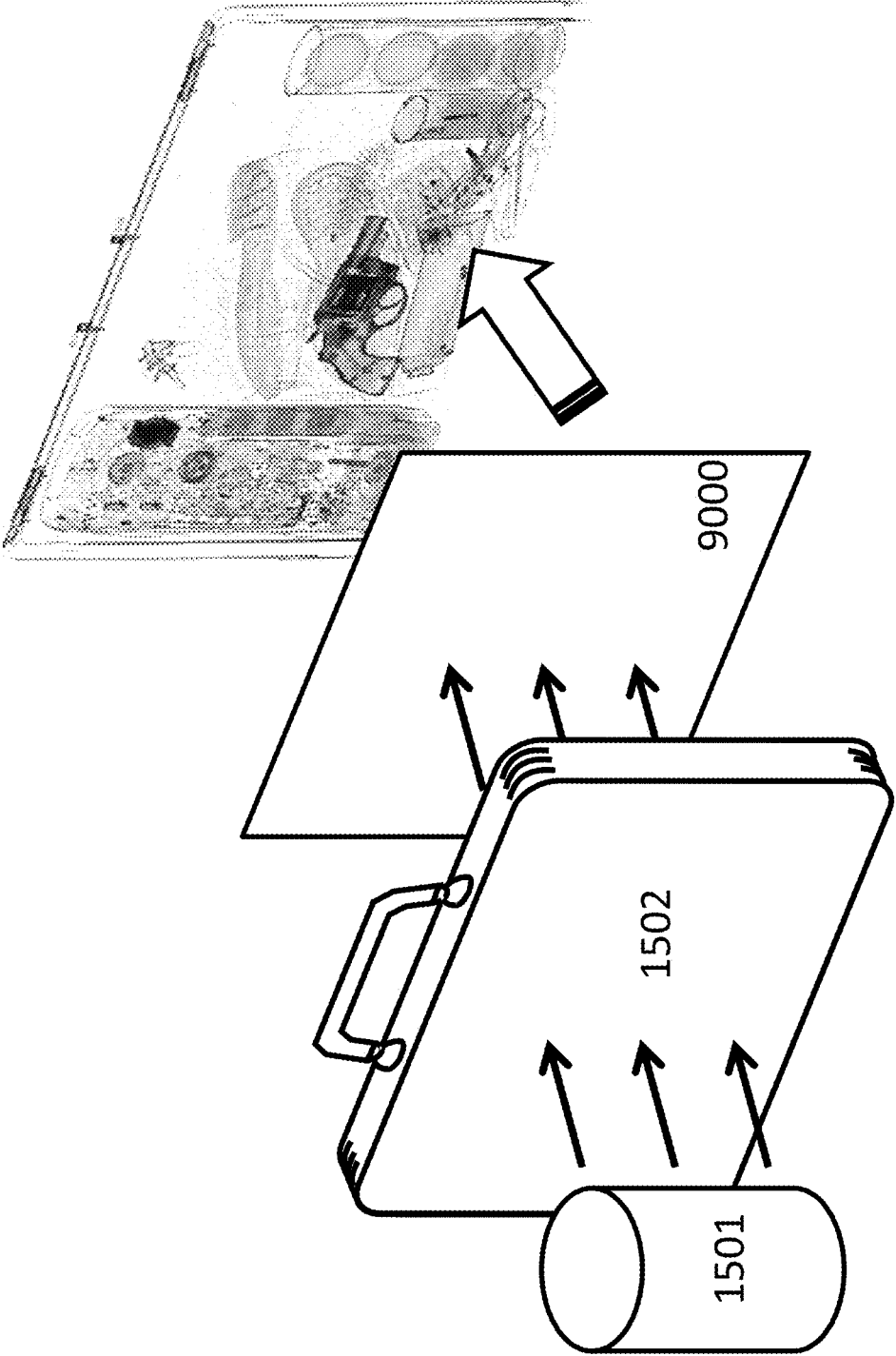

Fig. 19

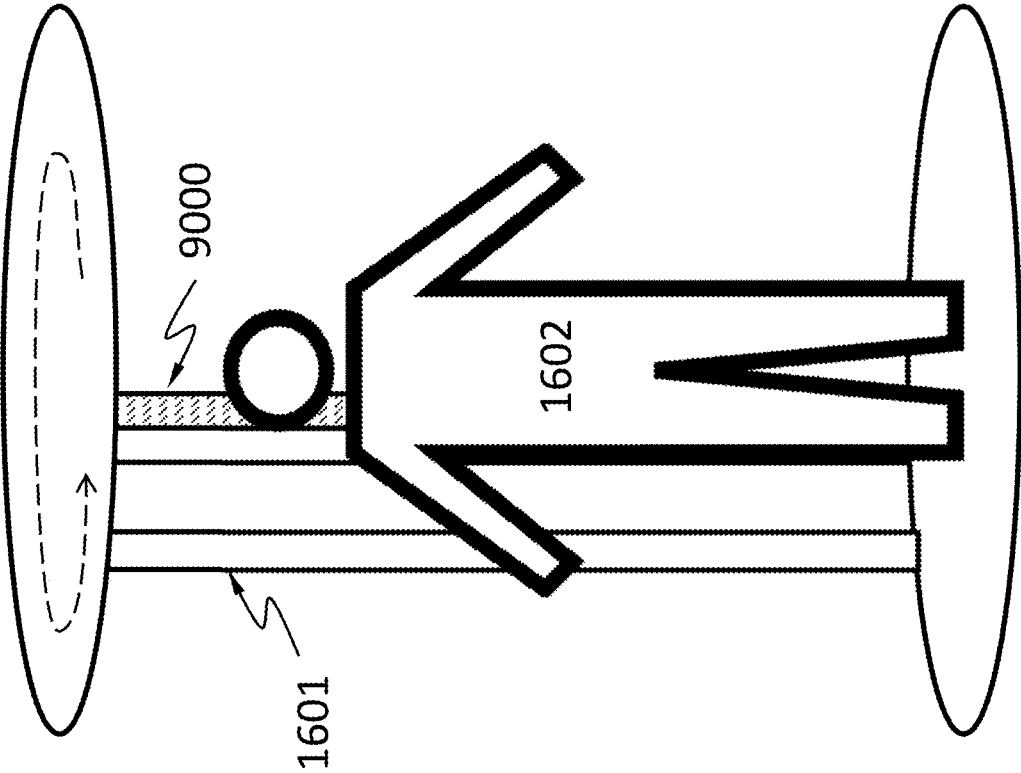

Fig. 20

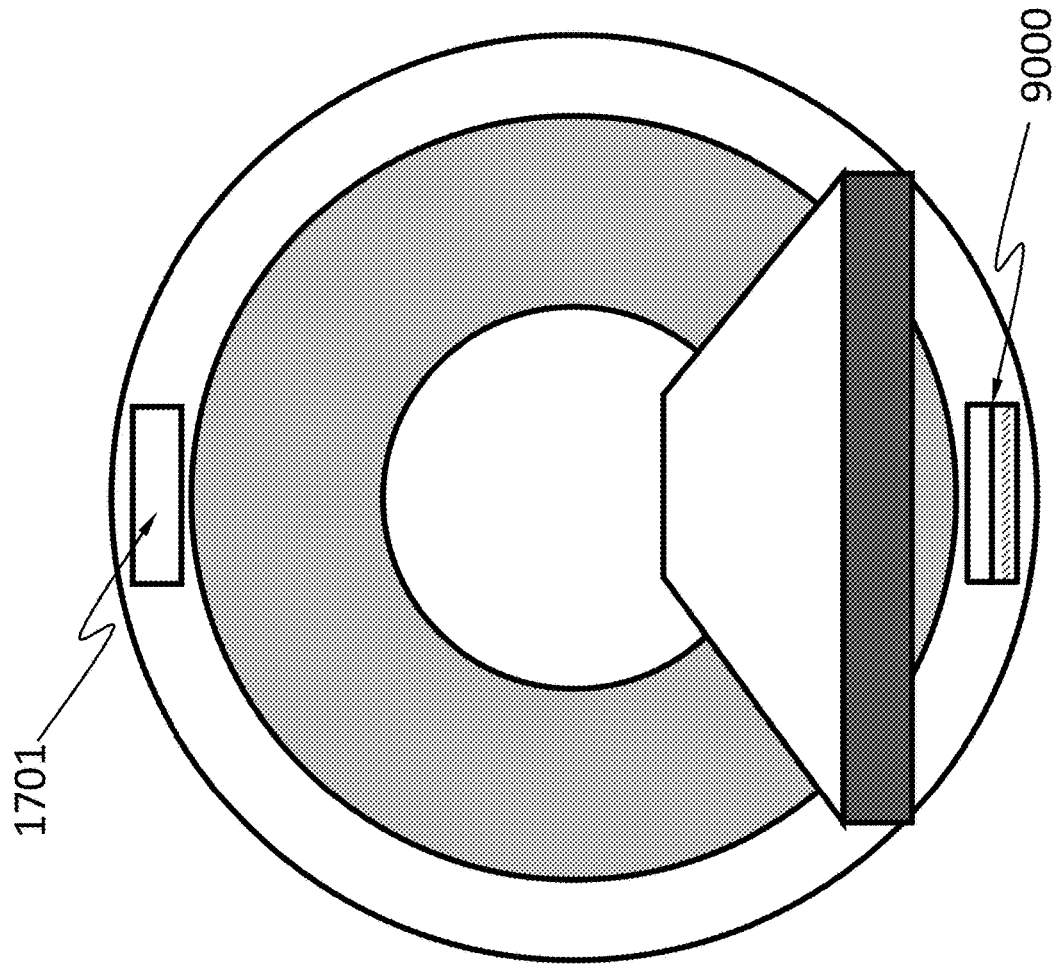

Fig. 21

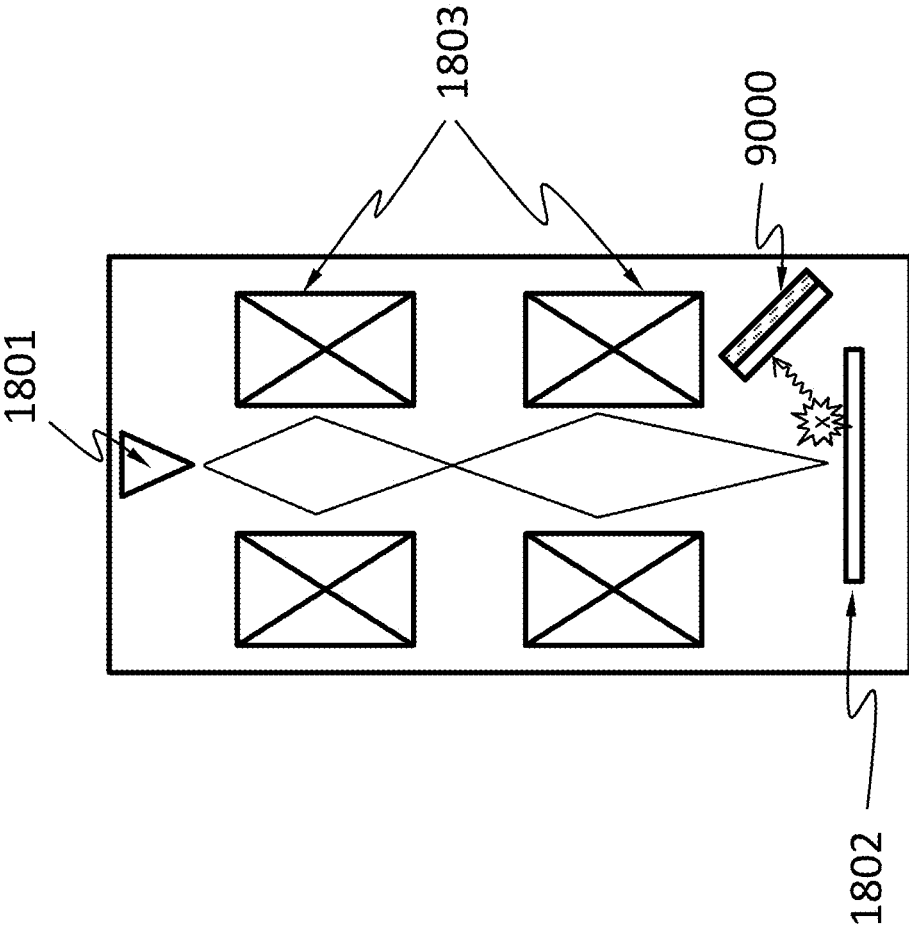

Fig. 22

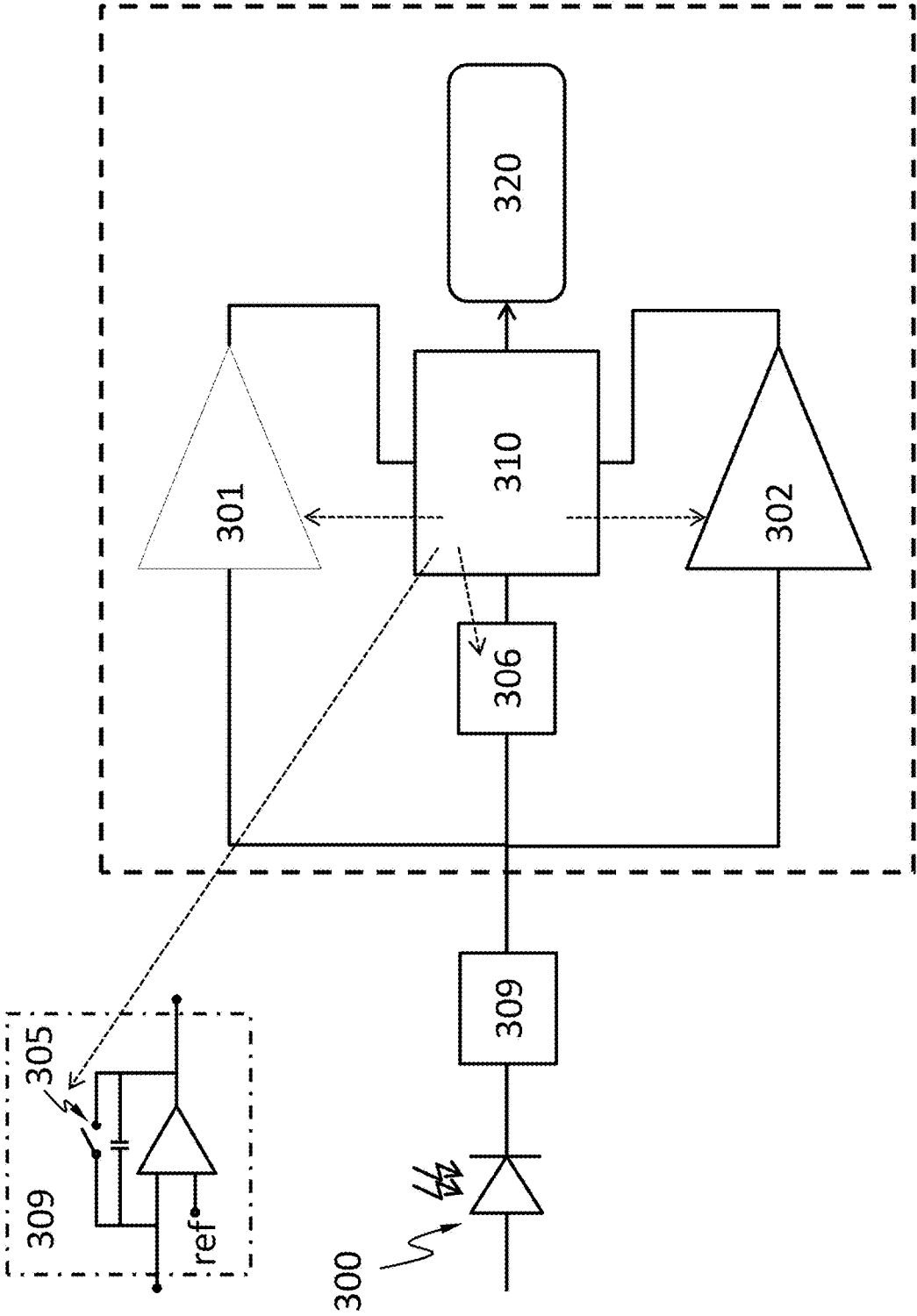

Fig. 23A

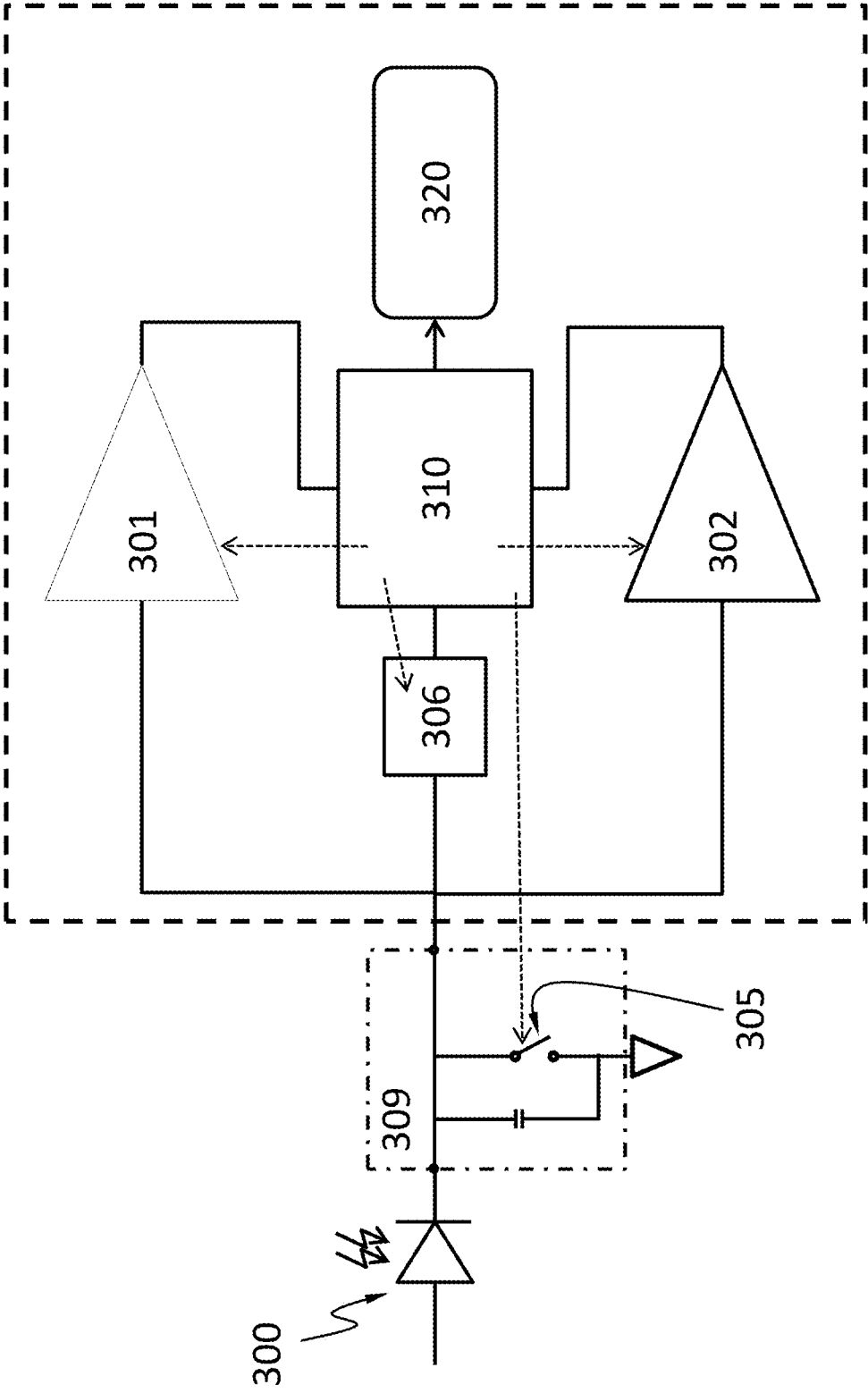

Fig. 23B

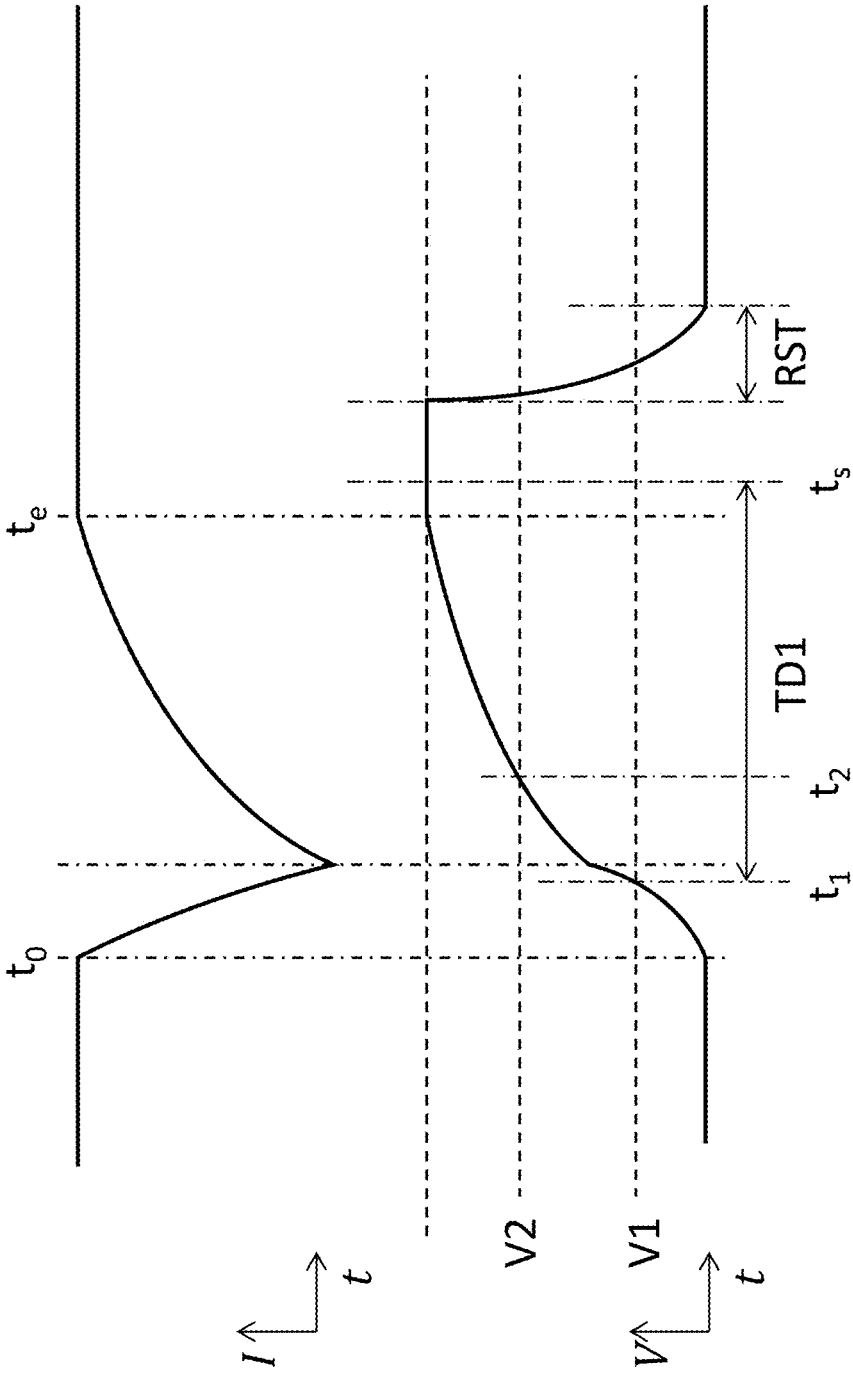

Fig. 24

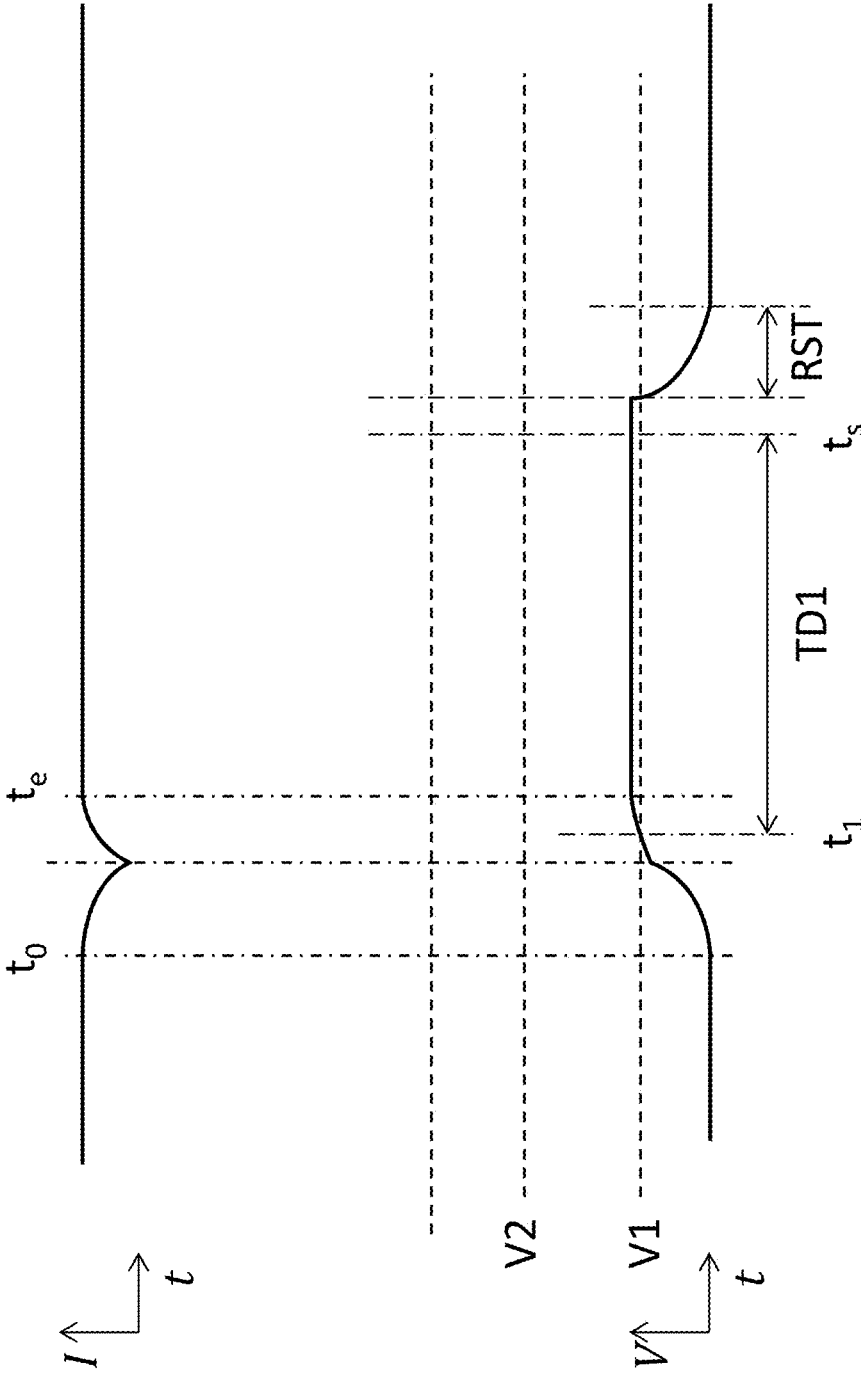

Fig. 25

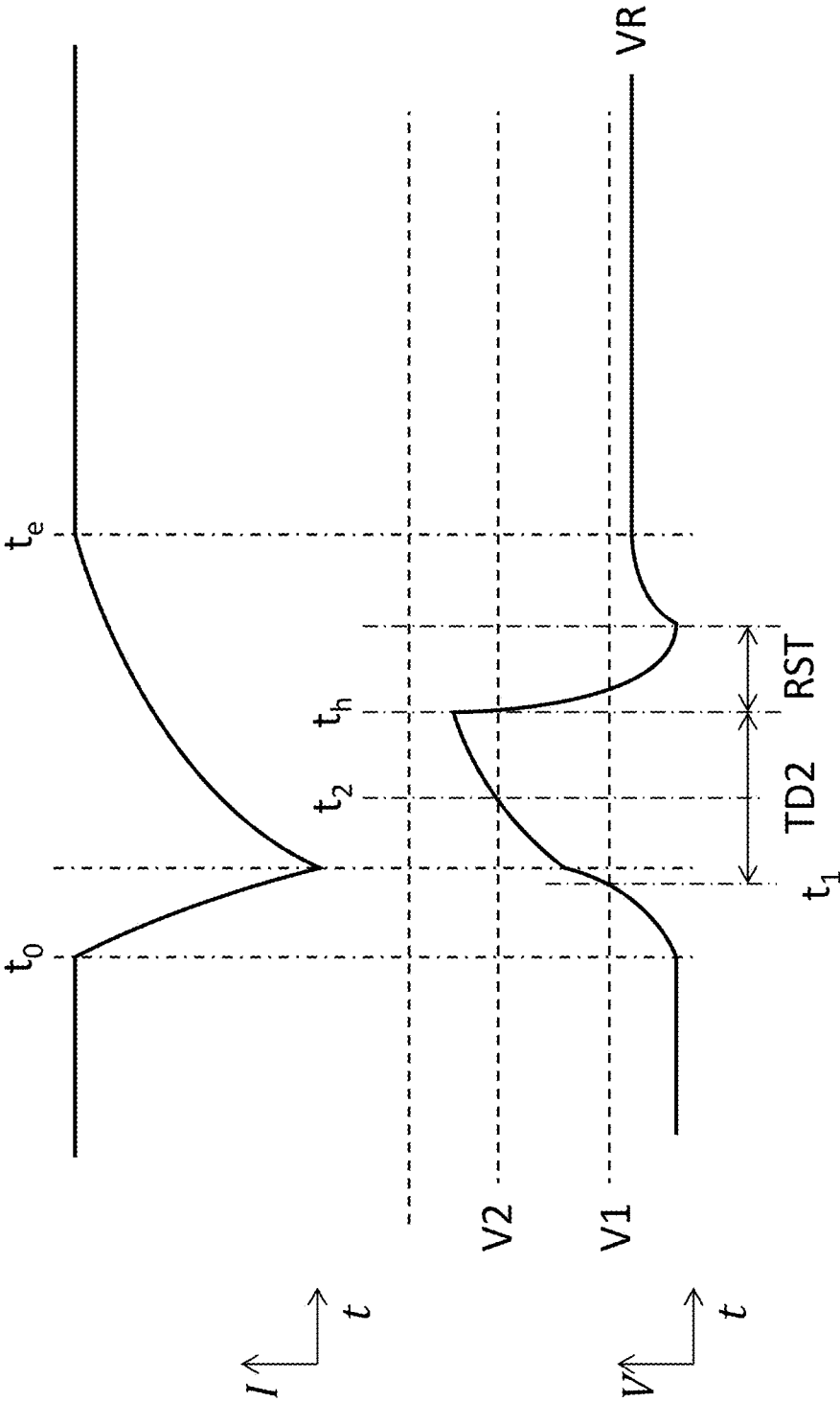

Fig. 26

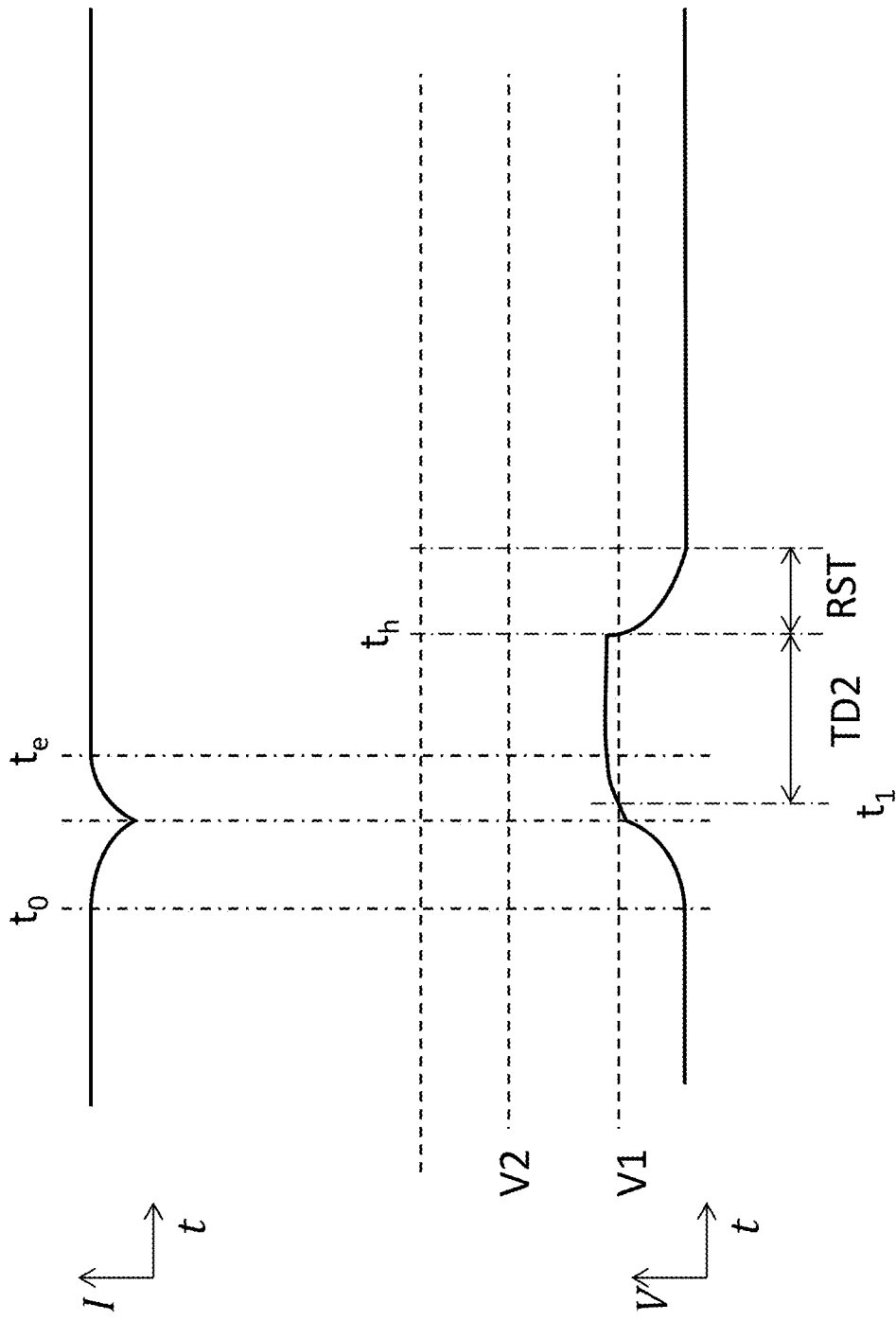

Fig. 27

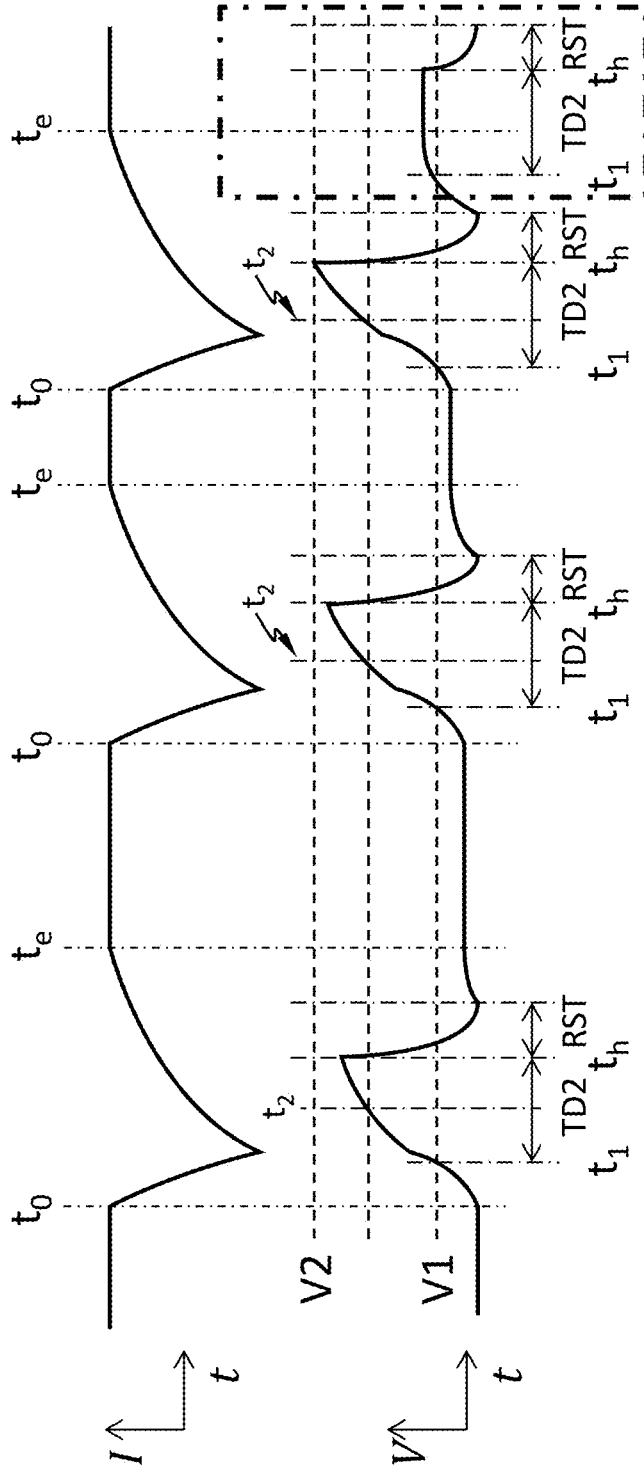

Fig. 28

PACKAGING OF SEMICONDUCTOR X-RAY DETECTORS

TECHNICAL FIELD

[0001] The disclosure herein relates to X-ray detectors, particularly relates to methods of packaging semiconductor X-ray detectors.

BACKGROUND

[0002] X-ray detectors may be devices used to measure the flux, spatial distribution, spectrum or other properties of X-rays.

[0003] X-ray detectors may be used for many applications. One important application is imaging. X-ray imaging is a radiography technique and can be used to reveal the internal structure of a non-uniformly composed and opaque object such as the human body.

[0004] Early X-ray detectors for imaging include photographic plates and photographic films. A photographic plate may be a glass plate with a coating of light-sensitive emulsion. Although photographic plates were replaced by photographic films, they may still be used in special situations due to the superior quality they offer and their extreme stability. A photographic film may be a plastic film (e.g., a strip or sheet) with a coating of light-sensitive emulsion.

[0005] In the 1980s, photostimulable phosphor plates (PSP plates) became available. A PSP plate may contain a phosphor material with color centers in its lattice. When the PSP plate is exposed to X-ray, electrons excited by X-ray are trapped in the color centers until they are stimulated by a laser beam scanning over the plate surface. As the plate is scanned by laser, trapped excited electrons give off light, which is collected by a photomultiplier tube. The collected light is converted into a digital image. In contrast to photographic plates and photographic films, PSP plates can be reused.

[0006] Another kind of X-ray detectors are X-ray image intensifiers. Components of an X-ray image intensifier are usually sealed in a vacuum. In contrast to photographic plates, photographic films, and PSP plates, X-ray image intensifiers may produce real-time images, i.e., do not require post-exposure processing to produce images. X-ray first hits an input phosphor (e.g., cesium iodide) and is converted to visible light. The visible light then hits a photocathode (e.g., a thin metal layer containing cesium and antimony compounds) and causes emission of electrons. The number of emitted electrons is proportional to the intensity of the incident X-ray. The emitted electrons are projected, through electron optics, onto an output phosphor and cause the output phosphor to produce a visible-light image.

[0007] Scintillators operate somewhat similarly to X-ray image intensifiers in that scintillators (e.g., sodium iodide) absorb X-ray and emit visible light, which can then be detected by a suitable image sensor for visible light. In scintillators, the visible light spreads and scatters in all directions and thus reduces spatial resolution. Reducing the scintillator thickness helps to improve the spatial resolution but also reduces absorption of X-ray. A scintillator thus has to strike a compromise between absorption efficiency and resolution.

[0008] Semiconductor X-ray detectors largely overcome this problem by direct conversion of X-ray into electric signals. A semiconductor X-ray detector may include a

semiconductor layer that absorbs X-ray in wavelengths of interest. When an X-ray photon is absorbed in the semiconductor layer, multiple charge carriers (e.g., electrons and holes) are generated and swept under an electric field towards electrical contacts on the semiconductor layer. Cumbersome heat management required in currently available semiconductor X-ray detectors (e.g., Medipix) can make a detector with a large area and a large number of pixels difficult or impossible to produce.

SUMMARY

[0009] Disclosed herein is an image sensor comprising: a plurality of packages arranged in a plurality of layers; wherein each of the packages comprises an X-ray detector mounted on a printed circuit board (PCB); wherein the packages are mounted on one or more system PCBs; wherein within an area encompassing a plurality of the X-ray detectors in the plurality of packages, a dead zone of the packages in each of the plurality of layers is shadowed by the packages in the other layers.

[0010] According to an embodiment, the packages are parallel to the one or more system PCBs.

[0011] According to an embodiment, the packages are tilted relative to the one or more system PCBs.

[0012] According to an embodiment, the packages in at least one of the layers are arranged in rows.

[0013] According to an embodiment, the packages in at least one of the rows partially overlap with one another.

[0014] According to an embodiment, among the packages in that row, a part of a dead zone of one package is shadowed by its neighboring package.

[0015] According to an embodiment, the packages in different layers are mounted on different system PCBs.

[0016] According to an embodiment, the packages are arranged such that light incident in the area is detectable by at least one of the packages.

[0017] According to an embodiment, the packages are arranged such that light incident in the area is detectable by at least two of the packages.

[0018] According to an embodiment, at least some of the packages each comprise multiple X-ray detectors mounted on the PCB.

[0019] According to an embodiment, the X-ray detector of at least one package comprises a perimeter zone wherein light incident in the perimeter zone is not detectable by the X-ray detector.

[0020] According to an embodiment, the packages are mounted on the one or more system PCBs by wire bonding.

[0021] According to an embodiment, the packages are rectangular in shape.

[0022] According to an embodiment, the packages are hexagonal in shape.

[0023] According to an embodiment, the packages are mounted on the one or more system PCBs by plugs and receptacles.

[0024] According to an embodiment, the packages are mounted on the one or more system PCBs by plugs, spacers and receptacles.

[0025] According to an embodiment, the X-ray detector of at least one of the packages comprises an X-ray absorption layer and an electronics layer; wherein the X-ray absorption layer comprises an electrode; wherein the electronics layer comprises an electronics system; wherein the electronics system comprises: a first voltage comparator configured to

compare a voltage of the electrode to a first threshold; a second voltage comparator configured to compare the voltage to a second threshold; a counter configured to register a number of X-ray photons reaching the X-ray absorption layer; a controller; wherein the controller is configured to start a time delay from a time at which the first voltage comparator determines that an absolute value of the voltage equals or exceeds an absolute value of the first threshold; wherein the controller is configured to activate the second voltage comparator during the time delay; wherein the controller is configured to cause the number registered by the counter to increase by one, if the second voltage comparator determines that an absolute value of the voltage equals or exceeds an absolute value of the second threshold.

[0026] According to an embodiment, the electronics system further comprises a capacitor module electrically connected to the electrode, wherein the capacitor module is configured to collect charge carriers from the electrode.

[0027] According to an embodiment, the controller is configured to activate the second voltage comparator at a beginning or expiration of the time delay.

[0028] According to an embodiment, the electronics system further comprises a voltmeter, wherein the controller is configured to cause the voltmeter to measure the voltage upon expiration of the time delay.

[0029] According to an embodiment, the controller is configured to determine an X-ray photon energy based on a value of the voltage measured upon expiration of the time delay.

[0030] According to an embodiment, the controller is configured to connect the electrode to an electrical ground.

[0031] According to an embodiment, a rate of change of the voltage is substantially zero at expiration of the time delay.

[0032] According to an embodiment, a rate of change of the voltage is substantially non-zero at expiration of the time delay.

[0033] Disclosed herein is a system comprising the image sensor disclosed herein and an X-ray source, wherein the system is configured to perform X-ray radiography on human chest or abdomen.

[0034] Disclosed herein is a system comprising the image sensor disclosed herein and an X-ray source, wherein the system is configured to perform X-ray radiography on human mouth.

[0035] Disclosed herein is a cargo scanning or non-intrusive inspection (NII) system, comprising the image sensor disclosed herein and an X-ray source, wherein the cargo scanning or non-intrusive inspection (NII) system is configured to form an image using backscattered X-ray.

[0036] Disclosed herein is a cargo scanning or non-intrusive inspection (NII) system, comprising the image sensor disclosed herein and an X-ray source, wherein the cargo scanning or non-intrusive inspection (NII) system is configured to form an image using X-ray transmitted through an object inspected.

[0037] Disclosed herein is a full-body scanner system comprising the image sensor disclosed herein and an X-ray source.

[0038] Disclosed herein is an X-ray computed tomography (X-ray CT) system comprising the image sensor disclosed herein and an X-ray source.

[0039] Disclosed herein is an electron microscope comprising the image sensor disclosed herein, an electron source and an electronic optical system.

[0040] Disclosed herein is a system comprising the image sensor disclosed herein, wherein the system is an X-ray telescope, or an X-ray microscopy, or wherein the system is configured to perform mammography, industrial defect detection, microradiography, casting inspection, weld inspection, or digital subtraction angiography.

BRIEF DESCRIPTION OF FIGURES

[0041] FIG. 1A schematically shows a cross-sectional view of the detector, according to an embodiment.

[0042] FIG. 1B schematically shows a detailed cross-sectional view of the detector, according to an embodiment.

[0043] FIG. 1C schematically shows an alternative detailed cross-sectional view of the detector, according to an embodiment.

[0044] FIG. 2 schematically shows that the device may have an array of pixels, according to an embodiment.

[0045] FIG. 3 schematically shows a cross-sectional view of an electronics layer in the detector, according to an embodiment.

[0046] FIG. 4A schematically shows a top view of a package including one copy of the detector and a printed circuit board (PCB).

[0047] FIG. 4B schematically shows a cross-sectional view of an image sensor, where a plurality of the packages of FIG. 4A are mounted to another PCB.

[0048] FIG. 5A and FIG. 5B schematically show a multiple layer arrangement of packages of FIG. 4A in an image sensor, according to an embodiment.

[0049] FIG. 6A and FIG. 6B schematically show a multiple layer arrangement of packages of FIG. 4A in an image sensor, according to an embodiment.

[0050] FIG. 7A and FIG. 7B schematically show a multiple layer arrangement of packages of FIG. 4A in an image sensor, according to an embodiment.

[0051] FIG. 8A schematically shows a top view of a package including multiple copies of the detector and a printed circuit board (PCB).

[0052] FIG. 8B schematically shows a cross-sectional view of an image sensor, where a plurality of the packages of FIG. 8A are mounted to another PCB.

[0053] FIG. 9A and FIG. 9B schematically show a multiple layer arrangement of packages of FIG. 8A in an image sensor, according to an embodiment.

[0054] FIG. 10A and FIG. 10B schematically show a multiple layer arrangement of packages of FIG. 8A in an image sensor, according to an embodiment.

[0055] FIG. 11A and FIG. 11B schematically show a multiple layer arrangement of packages of FIG. 8A in an image sensor, according to an embodiment.

[0056] FIG. 12A schematically shows an example of a set of four packages, each including multiple detectors mounted to a single PCB.

[0057] FIG. 12B schematically shows that the four packages may be stacked in an image sensor.

[0058] FIG. 12C schematically shows a cross-sectional view of the image sensor.

[0059] FIG. 13A schematically shows an example of a set of three packages, each including multiple detectors mounted to a single PCB.

[0060] FIG. 13B schematically shows that the three packages may be stacked in an image sensor.

[0061] FIG. 13C schematically shows a cross-sectional view of the image sensor.

[0062] FIG. 14A schematically shows an example of a set of three packages, each including multiple detectors mounted to a single PCB.

[0063] FIG. 14B schematically shows that the three packages may be stacked in an image sensor.

[0064] FIG. 14C schematically shows a cross-sectional view of the image sensor.

[0065] FIG. 15A schematically shows how packages of FIG. 4A or FIG. 8A in different layers may be mounted to a PCB in an image sensor, according to an embodiment.

[0066] FIG. 15B schematically shows how packages of FIG. 4A or FIG. 8A in different layers may be mounted to a PCB in an image sensor, according to an embodiment.

[0067] FIG. 16 schematically shows a system comprising the semiconductor X-ray detector described herein, suitable for medical imaging such as chest X-ray radiography, abdominal X-ray radiography, etc., according to an embodiment

[0068] FIG. 17 schematically shows a system comprising the semiconductor X-ray detector described herein suitable for dental X-ray radiography, according to an embodiment.

[0069] FIG. 18 schematically shows a cargo scanning or non-intrusive inspection (NII) system comprising the semiconductor X-ray detector described herein, according to an embodiment.

[0070] FIG. 19 schematically shows another cargo scanning or non-intrusive inspection (NII) system comprising the semiconductor X-ray detector described herein, according to an embodiment.

[0071] FIG. 20 schematically shows a full-body scanner system comprising the semiconductor X-ray detector described herein, according to an embodiment.

[0072] FIG. 21 schematically shows an X-ray computed tomography (X-ray CT) system comprising the semiconductor X-ray detector described herein, according to an embodiment.

[0073] FIG. 22 schematically shows an electron microscope comprising the semiconductor X-ray detector described herein, according to an embodiment.

[0074] FIG. 23A and FIG. 23B each show a component diagram of an electronic system of the detector in FIG. 1A or FIG. 1B, according to an embodiment.

[0075] FIG. 24 schematically shows a temporal change of the electric current flowing through an electrode (upper curve) of a diode or an electrical contact of a resistor of an X-ray absorption layer exposed to X-ray, the electric current caused by charge carriers generated by an X-ray photon incident on the X-ray absorption layer, and a corresponding temporal change of the voltage of the electrode (lower curve), according to an embodiment.

[0076] FIG. 25 schematically shows a temporal change of the electric current flowing through the electrode (upper curve) caused by noise (e.g., dark current), and a corresponding temporal change of the voltage of the electrode (lower curve), in the electronic system operating in the way shown in FIG. 24, according to an embodiment.

[0077] FIG. 26 schematically shows a temporal change of the electric current flowing through an electrode (upper curve) of the X-ray absorption layer exposed to X-ray, the electric current caused by charge carriers generated by an

X-ray photon incident on the X-ray absorption layer, and a corresponding temporal change of the voltage of the electrode (lower curve), when the electronic system operates to detect incident X-ray photons at a higher rate, according to an embodiment.

[0078] FIG. 27 schematically shows a temporal change of the electric current flowing through the electrode (upper curve) caused by noise (e.g., dark current), and a corresponding temporal change of the voltage of the electrode (lower curve), in the electronic system operating in the way shown in FIG. 26, according to an embodiment.

[0079] FIG. 28 schematically shows a temporal change of the electric current flowing through the electrode (upper curve) caused by charge carriers generated by a series of X-ray photons incident on the X-ray absorption layer, and a corresponding temporal change of the voltage of the electrode, in the electronic system operating in the way shown in FIG. 10 with RST expires before t_e , according to an embodiment.

DETAILED DESCRIPTION

[0080] FIG. 1A schematically shows a cross-sectional view of the detector 100, according to an embodiment. The detector 100 may include an X-ray absorption layer 110 and an electronics layer 120 (e.g., an ASIC) for processing or analyzing electrical signals incident X-ray generates in the X-ray absorption layer 110. In an embodiment, the detector 100 does not comprise a scintillator. The X-ray absorption layer 110 may include a semiconductor material such as, silicon, germanium, GaAs, CdTe, CdZnTe, or a combination thereof. The semiconductor may have a high mass attenuation coefficient for the X-ray energy of interest.

[0081] As shown in a detailed cross-sectional view of the detector 100 in FIG. 1B, according to an embodiment, the X-ray absorption layer 110 may include one or more diodes (e.g., p-i-n or p-n) formed by a first doped region 111, one or more discrete regions 114 of a second doped region 113. The second doped region 113 may be separated from the first doped region 111 by an optional the intrinsic region 112. The discrete portions 114 are separated from one another by the first doped region 111 or the intrinsic region 112. The first doped region 111 and the second doped region 113 have opposite types of doping (e.g., region 111 is p-type and region 113 is n-type, or region 111 is n-type and region 113 is p-type). In the example in FIG. 1B, each of the discrete regions 114 of the second doped region 113 forms a diode with the first doped region 111 and the optional intrinsic region 112. Namely, in the example in FIG. 1B, the X-ray absorption layer 110 has a plurality of diodes having the first doped region 111 as a shared electrode. The first doped region 111 may also have discrete portions.

[0082] When an X-ray photon hits the X-ray absorption layer 110 including diodes, the X-ray photon may be absorbed and generate one or more charge carriers by a number of mechanisms. An X-ray photon may generate 10 to 100000 charge carriers. The charge carriers may drift to the electrodes of one of the diodes under an electric field. The field may be an external electric field. The electrical contact 119B may include discrete portions each of which is in electrical contact with the discrete regions 114. In an embodiment, the charge carriers may drift in directions such that the charge carriers generated by a single X-ray photon are not substantially shared by two different discrete regions 114 (“not substantially shared” here means less than 2%, less

than 0.5%, less than 0.1%, or less than 0.01% of these charge carriers flow to a different one of the discrete regions **114** than the rest of the charge carriers). Charge carriers generated by an X-ray photon incident around the footprint of one of these discrete regions **114** are not substantially shared with another of these discrete regions **114**. A pixel **150** associated with a discrete region **114** may be an area around the discrete region **114** in which substantially all (more than 98%, more than 99.5%, more than 99.9%, or more than 99.99% of) charge carriers generated by an X-ray photon incident therein flow to the discrete region **114**. Namely, less than 2%, less than 1%, less than 0.1%, or less than 0.01% of these charge carriers flow beyond the pixel.

[0083] As shown in an alternative detailed cross-sectional view of the detector **100** in FIG. 1C, according to an embodiment, the X-ray absorption layer **110** may include a resistor of a semiconductor material such as, silicon, germanium, GaAs, CdTe, CdZnTe, or a combination thereof, but does not include a diode. The semiconductor may have a high mass attenuation coefficient for the X-ray energy of interest.

[0084] When an X-ray photon hits the X-ray absorption layer **110** including a resistor but not diodes, it may be absorbed and generate one or more charge carriers by a number of mechanisms. An X-ray photon may generate 10 to 100000 charge carriers. The charge carriers may drift to the electrical contacts **119A** and **119B** under an electric field. The field may be an external electric field. The electrical contact **119B** includes discrete portions. In an embodiment, the charge carriers may drift in directions such that the charge carriers generated by a single X-ray photon are not substantially shared by two different discrete portions of the electrical contact **119B** (“not substantially shared” here means less than 2%, less than 0.5%, less than 0.1%, or less than 0.01% of these charge carriers flow to a different one of the discrete portions than the rest of the charge carriers). Charge carriers generated by an X-ray photon incident around the footprint of one of these discrete portions of the electrical contact **119B** are not substantially shared with another of these discrete portions of the electrical contact **119B**. A pixel **150** associated with a discrete portion of the electrical contact **119B** may be an area around the discrete portion in which substantially all (more than 98%, more than 99.5%, more than 99.9% or more than 99.99% of) charge carriers generated by an X-ray photon incident therein flow to the discrete portion of the electrical contact **119B**. Namely, less than 2%, less than 0.5%, less than 0.1%, or less than 0.01% of these charge carriers flow beyond the pixel associated with the one discrete portion of the electrical contact **119B**.

[0085] The electronics layer **120** may include an electronic system **121** suitable for processing or interpreting signals generated by X-ray photons incident on the X-ray absorption layer **110**. The electronic system **121** may include an analog circuitry such as a filter network, amplifiers, integrators, and comparators, or a digital circuitry such as a microprocessors, and memory. The electronic system **121** may include components shared by the pixels or components dedicated to a single pixel. For example, the electronic system **121** may include an amplifier dedicated to each pixel and a micro-processor shared among all the pixels. The electronic system **121** may be electrically connected to the pixels by vias **131**. Space among the vias may be filled with a filler material **130**, which may increase the mechanical stability of the connec-

tion of the electronics layer **120** to the X-ray absorption layer **110**. Other bonding techniques are possible to connect the electronic system **121** to the pixels without using vias.

[0086] FIG. 2 schematically shows that the detector **100** may have an array of pixels **150**. The array may be a rectangular array, a honeycomb array, a hexagonal array or any other suitable array. Each pixel **150** may be configured to detect an X-ray photon incident thereon, measure the energy of the X-ray photon, or both. For example, each pixel **150** may be configured to count numbers of X-ray photons incident thereon whose energy falls in a plurality of bins, within a period of time. All the pixels **150** may be configured to count the numbers of X-ray photons incident thereon within a plurality of bins of energy within the same period of time. Each pixel **150** may have its own analog-to-digital converter (ADC) configured to digitize an analog signal representing the energy of an incident X-ray photon into a digital signal. The ADC may have a resolution of 10 bits or higher. Each pixel **150** may be configured to measure its dark current, such as before or concurrently with each X-ray photon incident thereon. Each pixel **150** may be configured to deduct the contribution of the dark current from the energy of the X-ray photon incident thereon. The pixels **150** may be configured to operate in parallel. For example, when one pixel **150** measures an incident X-ray photon, another pixel **150** may be waiting for an X-ray photon to arrive. The pixels **150** may be but do not have to be individually addressable.

[0087] FIG. 3 schematically shows the electronics layer **120** according to an embodiment. The electronic layer **120** comprises a substrate **122** having a first surface **124** and a second surface **128**. A “surface” as used herein is not necessarily exposed, but can be buried wholly or partially. The electronic layer **120** comprises one or more electric contacts **125** on the first surface **124**. The one or more electric contacts **125** may be configured to be electrically connected to one or more electrical contacts **119B** of the X-ray absorption layer **110**. The electronics system **121** may be in or on the substrate **122**.

[0088] The substrate **122** may be a thinned substrate. For example, the substrate may have a thickness of 750 microns or less, 200 microns or less, 100 microns or less, 50 microns or less, 20 microns or less, or 5 microns or less. The substrate **122** may be a silicon substrate or a substrate or other suitable semiconductor or insulator. The substrate **122** may be produced by grinding a thicker substrate to a desired thickness.

[0089] The one or more electric contacts **125** may be a layer of metal or doped semiconductor. For example, the electric contacts **125** may be gold, copper, platinum, palladium, doped silicon, etc.

[0090] FIG. 3 schematically shows bonding between the X-ray absorption layer **110** and the electronic layer **120** at the electrical contact **119B** of the X-ray absorption layer **110** and electrical contacts **125** of the electronic layer **120**. The bonding may be by a suitable technique such as direct bonding or flip chip bonding.

[0091] Direct bonding is a wafer bonding process without any additional intermediate layers (e.g., solder bumps). The bonding process is based on chemical bonds between two surfaces. Direct bonding may be at elevated temperature but not necessarily so.

[0092] Flip chip bonding uses solder bumps **199** deposited onto contact pads (e.g., the electrical contact **119B** of the

X-ray absorption layer 110 or the electrical contacts 125). Either the X-ray absorption layer 110 or the electronic layer 120 is flipped over and the electrical contact 119B of the X-ray absorption layer 110 are aligned to the electrical contacts 125. The solder bumps 199 may be melted to solder the electrical contact 119B and the electrical contacts 125 together. Any void space among the solder bumps 199 may be filled with an insulating material.

[0093] FIG. 4A schematically shows a top view of a package 200 including the detector 100 and a printed circuit board (PCB) 400. The term “PCB” as used herein is not limited to a particular material. For example, a PCB may include a semiconductor. The detector 100 is mounted to the PCB 400. The wiring between the detector 100 and the PCB 400 is not shown for the sake of clarity. The PCB 400 has only a single detector 100. The PCB 400 may have an area not covered by the detector 100, for accommodating bonding wires 410. The detector 100 may have an active area 190, which is where the pixels 150 are located. The detector 100 may have a perimeter zone 195 near the edges of the detector 100. The perimeter zone 195 has no pixels and the detector 100 does not detect photons incident on the perimeter zone 195.

[0094] The electrical connection between the PCBs 400 in the packages 200 and a system PCB 450 are made by bonding wires 410. In order to accommodate the bonding wires 410 on the PCB 400, the PCB 400 has an area 405 not covered by the detector 100. In order to accommodate the bonding wires 410 on the system PCB 450, the packages 200 have gaps in between. The gaps may be approximately 1 mm or more. Light incident on the perimeter zones 195, on the area 405 or on the gaps cannot be detected by the packages 200 on the system PCB 450. A dead zone of a package (e.g., package 200) is the area of the photon-receiving surface of the package, in which incident photons cannot be detected by the detector or detectors in the package. In this example shown in FIG. 4A, the dead zone of the package 200 includes the perimeter zones 195 and the area 405. A dead zone (e.g., 488) of a group of packages (e.g., packages mounted on the same PCB, packages arranged in the same layer) is the combination of the dead zones of the packages in the group and the gaps among the packages.

[0095] In order to capture the light incident in the dead zone 488 of a layer of the packages, the packages 200 may be arranged in multiple layers, where the packages 200 are arranged such that light incident on the dead zone 488 of one layer is captured by the packages 200 in another layer.

[0096] FIG. 5A and FIG. 5B schematically show a multiple layer arrangement of packages 200 in an image sensor, according to an embodiment. In this embodiment, the packages 200 are arranged in at least three layers 510, 520 and 530. All of the packages 200 may be mounted to a system PCB 500. The packages 200 may be parallel to the system PCB 500 as shown in the cross-sectional view in FIG. 5B. The layer 510 is closest to the system PCB 500 among the layers 510, 520 and 530. The layer 530 is farthest from the system PCB 500 among the layers 510, 520 and 530. Within an area marked by the dotted box (in a top view in FIG. 5A) and dotted double arrow (in a cross-sectional view in FIG. 5B), the dead zone of the layer 510 is shadowed by the packages 200 in the layer 520 or the packages 200 in the layer 530; the dead zone of the layer 520 is shadowed by the packages 200 in the layer 530 or the packages 200 in the layer 510; the dead zone of the layer 530 is shadowed by the

packages 200 in the layer 510 or the packages 200 in the layer 520. The term “shadowed” does not imply a particular order; a first area shadowed by a second area means that the first area is entirely within the perimeter of the second area when viewed along a direction perpendicular to the system PCB, notwithstanding that the first area and the second area may be in different layers. The area marked by the dotted box or dotted double arrow encompasses a plurality of the detectors 100 among those in the three layers 510, 520 and 530. Light incident in the area marked by the dotted box or dotted double arrow is within an active area of at least one package 200 among those in the three layers 510, 520 and 530. Namely, light incident in the area marked by the dotted box or dotted double arrow is detectable by at least one package 200 among those in the layers 510, 520 and 530. According to an embodiment, the packages 200 arranged in the at least three layers 510, 520 and 530 may be respectively mounted to PCBs 511, 521 and 531; the PCBs 511, 521 and 531 may be mounted to the system PCB 500.

[0097] FIG. 6A and FIG. 6B schematically show a multiple layer arrangement of packages 200 in an image sensor, according to an embodiment. In this embodiment, the packages 200 are arranged in at least two layers 610 and 620. The packages 200 in the layers 610 and 620 are respectively mounted to a system PCB 601 and a system PCB 602. The packages 200 may be tilted relative to the system PCB 601 and system PCB 602 as shown in the cross-sectional view in FIG. 6B. The packages 200 within the layer 610 or the layer 620 are arranged in rows. The packages 200 in a row partially overlap with one another (analogous to a column of roofing shingles) as shown in FIG. 6A and FIG. 6B, such that, within a row, a part of the dead zone of a package is shadowed by its neighboring package. Within an area marked by the dotted box (in a top view in FIG. 6A) and dotted double arrow (in a cross-sectional view in FIG. 6B), the dead zone (including the gaps between the rows) of the layer 610 is shadowed by the rows of packages 200 in the layer 620; the dead zone of the layer 620 is shadowed by the rows of packages 200 in the layer 610. The area marked by the dotted box or dotted double arrow encompasses a plurality of the detectors 100 among those in the two layers 610 and 620. Light incident in the area marked by the dotted box or dotted double arrow is within an active area of at least one package 200 among those in the layers 610 and 620. Namely, light incident in the area marked by the dotted box or dotted double arrow is detectable by at least one package 200 among those in the layers 610 and 620.

[0098] FIG. 7A and FIG. 7B schematically show a multiple layer arrangement of packages 200 in an image sensor, according to an embodiment. This embodiment is similar to that illustrated in FIG. 6A and FIG. 6B except that the packages 200 are arranged in at least three layers 710, 720 and 730. The packages 200 in the layers 710, 720 and 730 are respectively mounted to a system PCB 701, a system PCB 702 and a system PCB 703. The packages 200 may be tilted relative to the system PCB 701, 702 or 703 as shown in the cross-sectional view in FIG. 7B. The packages 200 within each of the layers 710, 720 and 730 are arranged in rows. The packages 200 in a row partially overlap with one another (analogous to a column of roofing shingles) as shown in FIG. 7A and FIG. 7B, such that, within a row, a part of the dead zone of a package is shadowed by its neighboring package. Within an area marked by the dotted box (in a top view in FIG. 7A) and dotted double arrow (in

a cross-sectional view in FIG. 7B), the dead zone (including the gaps between the rows) of the layer 710 is shadowed by the rows of packages 200 in both of the layers 720 and 730; the dead zone of the layer 720 is shadowed by the rows of packages 200 in both of the layers 710 and 730; the dead zone of the layer 730 is shadowed by the rows of packages 200 in both of the layers 710 and 720. The area marked by the dotted box or dotted double arrow encompasses a plurality of the detectors 100 among those in the three layers 710, 720 and 730. Light incident in the area marked by the dotted box or dotted double arrow is within an active area of at least two packages 200 among those in the layers 710, 720 and 730. Namely, light incident in the area marked by the dotted box or dotted double arrow is detectable by at least two packages 200 among those in the layers 710, 720 and 730.

[0099] Unlike the package 200 illustrated in FIG. 4A, multiple detectors 100 may be mounted onto a PCB. FIG. 8A schematically shows a package including multiple detectors 100 mounted to a single PCB 899. The PCB 899 may have an area 805 not covered by the detector 100. The area 805 may include a portion of the PCB 810 for accommodating bonding wires 810 and gaps between the multiple detectors 100. Each of the detectors 100 has an active area 190, which is where the pixels 150 are located. Each of the detectors 100 may have a perimeter zone 195 near the edges. The perimeter zones 195 have no pixels and the detectors 100 do not detect photons incident on the perimeter zones 195.

[0100] FIG. 8B schematically shows a cross-sectional view of an image sensor, where a plurality of the packages 800 are mounted to a system PCB 850. The electrical connection between the PCBs 899 in the packages 800 and the system PCB 850 are made by bonding wires 810. In order to accommodate the bonding wires 810 on the system PCB 850, the packages 800 have gaps in between. The gaps may be approximately 1 mm or more. Light incident on the areas 805 of the packages 800 or on the gaps between the packages 800 cannot be detected by the packages 800 on the system PCB 850. The dead zone 888 of the packages on the system PCB 850 includes the gaps between the packages 800, the areas 805 of the packages 800, and any perimeter zones of the detectors 100 in the packages.

[0101] In order to capture the light incident in the dead zone 800, the packages 800 may be arranged in multiple layers, where the packages 800 are arranged such that light incident on the dead zone 888 of one layer reaches the active areas 190 of the packages 800 in another layer. The package 800 than the individual detector 100. If any of the detectors 100 in a package 800 malfunctions, the entire package 800 may be replaced relatively easily because the relatively large size of the package 800 makes it easier to handle the package 800.

[0102] FIG. 9A and FIG. 9B schematically show a multiple layer arrangement of packages 800 in an image sensor, according to an embodiment. In this embodiment, the packages 800 are arranged in at least three layers 910, 920 and 930. All of the packages 800 may be mounted to a system PCB 900. The packages 800 may be parallel to the system PCB 900 as shown in the cross-sectional view in FIG. 9B. The layer 910 is closest to the system PCB 900 among the layers 910, 920 and 930. The layer 930 is farthest from the system PCB 900 among the layers 910, 920 and 930. Within an area marked by the dotted box (in a top view in FIG. 9A)

and dotted double arrow (in a cross-sectional view in FIG. 9B), the dead zone of the layer 910 is shadowed by the packages 800 in the layer 920 or the packages 800 in the layer 930; the dead zone of the layer 920 is shadowed by the packages 800 in the layer 930 or the packages 800 in the layer 910; the dead zone of the layer 930 is shadowed by the packages 800 in the layer 910 or the packages 800 in the layer 920. The area marked by the dotted box or dotted double arrow encompasses a plurality of the detectors 100 among those in the three layers 910, 920 and 930. Light incident in the area marked by the dotted box or dotted double arrow is within an active area of at least one package 800 among those in the three layers 910, 920 and 930. Namely, light incident in the area marked by the dotted box or dotted double arrow is detectable by at least one package 800 among those in the layers 910, 920 and 930. According to an embodiment, the packages 900 arranged in the at least three layers 910, 920 and 930 may be respectively mounted to PCBs 911, 921 and 931; the PCBs 911, 921 and 931 may be mounted to the system PCB 900.

[0103] FIG. 10A and FIG. 10B schematically show a multiple layer arrangement of packages 800 in an image sensor, according to an embodiment. In this embodiment, the packages 800 are arranged in at least two layers 1010 and 1020. The packages 800 in the layers 1010 and 1020 may be mounted to a system PCB 1000. The packages 800 may be tilted relative to the system PCB 1000 as shown in the cross-sectional view in FIG. 10B. The packages 800 within the layer 1010 or the layer 1020 partially overlap with one another (analogous to a column of roofing shingles) as shown in FIG. 10A and FIG. 10B, such that a part of the dead zone of a package is shadowed by its neighboring package. Within an area marked by the dotted box (in a top view in FIG. 10A) and dotted double arrow (in a cross-sectional view in FIG. 10B), the dead zone of the layer 1010 is shadowed by the packages 800 in the layer 1020; the dead zone of the layer 1020 is shadowed by the packages 800 in the layer 1010. The area marked by the dotted box or dotted double arrow encompasses a plurality of the detectors 100 among those in the two layers 1010 and 1020. Light incident in the area marked by the dotted box or dotted double arrow is within an active area of at least one package 800 among those in the layers 1010 and 1020. Namely, light incident in the area marked by the dotted box or dotted double arrow is detectable by at least one package 800 among those in the layers 1010 and 1020. According to an embodiment, the packages 800 arranged in the at least two layers 1010 and 1020 may be respectively mounted to PCBs 1011 and 1021; the PCBs 1011 and 1021 may be mounted to the system PCB 1000.

[0104] FIG. 11A and FIG. 11B schematically show a multiple layer arrangement of packages 800 in an image sensor, according to an embodiment. This embodiment is similar to that illustrated in FIG. 10A and FIG. 10B except that the packages 800 are arranged in at least three layers 1110, 1120 and 1130. The packages 800 in the layers 1110, 1120 and 1130 may be mounted to a system PCB 1100. The packages 800 may be tilted relative to the system PCB 1100 as shown in the cross-sectional view in FIG. 11B. The packages 800 within the layers 1110, 1120 or 1130 partially overlap with one another (analogous to a column of roofing shingles) as shown in FIG. 11A and FIG. 11B, such that a part of the dead zone of a package is shadowed by its neighboring package. Within an area marked by the dotted

box (in a top view in FIG. 11A) and dotted double arrow (in a cross-sectional view in FIG. 11B), the dead zone of the layer 1110 is shadowed by the packages 800 in both of the layers 1120 and 1130; the dead zone of the layer 1120 is shadowed by the packages 800 in both of the layers 1110 and 1130; the dead zone of the layer 1130 is shadowed by the packages 800 in both of the layers 1110 and 1120. The area marked by the dotted box or dotted double arrow encompasses a plurality of the detectors 100 among those in the three layers 1110, 1120 and 1130. Light incident in the area marked by the dotted box or dotted double arrow is within an active area of at least two packages 800 among those in the layers 1110, 1120 and 1130. Namely, light incident in the area marked by the dotted box or dotted double arrow is detectable by at least two packages 800 among those in the layers 1110, 1120 and 1130. According to an embodiment, the packages 800 arranged in the at least three layers 1110, 1120 and 1130 may be respectively mounted to PCBs 1111, 1121 and 1131; the PCBs 1111, 1121 and 1131 may be mounted to the system PCB 1100.

[0105] FIG. 12A schematically shows an example of a set of four packages, each including multiple detectors 100 mounted to a single PCB. The four packages each have an array of the detectors 100. The detectors 100 in the array may be arranged in multiple columns. FIG. 12B schematically shows that the four packages may be stacked in an image sensor such that light incident in the area marked by the dotted box (in a top view in FIG. 12B) or dotted double arrow (in a cross-sectional view in FIG. 12C) is within an active area of at least two of the four packages. The area marked by the dotted box or dotted double arrow encompasses a plurality of the detectors 100 among those in the four packages. Namely, light incident in the area marked by the dotted box or dotted double arrow is detectable by at least two of the four packages.

[0106] FIG. 13A schematically shows an example of a set of three packages, each including multiple detectors 100 mounted to a single PCB. The three packages each have an array of the detectors 100. The detectors 100 in the array may be arranged in multiple columns. FIG. 13B schematically shows that the three packages may be stacked in an image sensor such that light incident in the area marked by the dotted box (in a top view in FIG. 13B) or dotted double arrow (in a cross-sectional view in FIG. 13C) is within an active area of at least one of the three packages. The area marked by the dotted box or dotted double arrow encompasses a plurality of the detectors 100 among those in the three packages. Namely, light incident in the area marked by the dotted box or dotted double arrow is detectable by at least one of the three packages.

[0107] FIG. 14A schematically shows an example of a set of three packages, each including multiple detectors 100 mounted to a single PCB. The detectors 100 do not have to be rectangular in shape. For example, the detectors may be hexagonal in shape. The three packages each have an array of the detectors 100. The detectors 100 in the array may be arranged in a triangular grid. FIG. 14B schematically shows that the three packages may be stacked in an image sensor such that light incident in the area marked by the dotted box (in a top view in FIG. 14B) or dotted double arrow (in a cross-sectional view in FIG. 14C) is within an active area of at least one of the three packages. The area marked by the dotted box or dotted double arrow encompasses a plurality of the detectors 100 among those in the three packages.

Namely, light incident in the area marked by the dotted box or dotted double arrow is detectable by at least one of the three packages.

[0108] FIG. 15A schematically shows how packages 200 or 800 in different layers may be mounted to a system PCB 1500 in an image sensor, according to an embodiment. Each of the packages may have a plug 1510 electrically and mechanically connected thereto. The plugs 1510 may have different heights for the packages in different layers. The system PCB 1500 may have a plurality of receptacles 1520. The packages 200 or 800 may be plugged into the receptacles 1520 and supported to different distances from the system PCB 1500 by the plugs 1510.

[0109] FIG. 15B schematically shows how packages 200 or 800 in different layers may be mounted to a system PCB 1500 in an image sensor, according to an embodiment. Each of the packages may have a plug 1510 electrically and mechanically connected thereto. The plugs 1510 have the same height for the packages in different layers. The system PCB 1500 may have a plurality of receptacles 1520. The packages 200 or 800 may be plugged into spacers 1530 and the spacers 1530 may be plugged into the receptacles 1520. The spacers 1530 may have different heights for the packages in different layers. The packages are supported to different distances from the system PCB 1500 by the plugs 1510 and the spacers 1530.

[0110] FIG. 16 schematically shows a system comprising an image sensor 9000 as described in relation to FIG. 4A-FIG. 15B. The system may be used for medical imaging such as chest X-ray radiography, abdominal X-ray radiography, etc. The system comprises an X-ray source 1201. X-ray emitted from the X-ray source 1201 penetrates an object 1202 (e.g., a human body part such as chest, limb, abdomen), is attenuated by different degrees by the internal structures of the object 1202 (e.g., bones, muscle, fat and organs, etc.), and is projected to the image sensor 9000. The image sensor 9000 forms an image by detecting the intensity distribution of the X-ray.

[0111] FIG. 17 schematically shows a system comprising an image sensor 9000 as described in relation to FIG. 4A-FIG. 15B. The system may be used for medical imaging such as dental X-ray radiography. The system comprises an X-ray source 1301. X-ray emitted from the X-ray source 1301 penetrates an object 1302 that is part of a mammal (e.g., human) mouth. The object 1302 may include a maxilla bone, a palate bone, a tooth, the mandible, or the tongue. The X-ray is attenuated by different degrees by the different structures of the object 1302 and is projected to the image sensor 9000. The image sensor 9000 forms an image by detecting the intensity distribution of the X-ray. Teeth absorb X-ray more than dental caries, infections, periodontal ligament. The dosage of X-ray radiation received by a dental patient is typically small (around 0.150 mSv for a full mouth series).

[0112] FIG. 18 schematically shows a cargo scanning or non-intrusive inspection (NII) system comprising an image sensor 9000 as described in relation to FIG. 4A-FIG. 15B. The system may be used for inspecting and identifying goods in transportation systems such as shipping containers, vehicles, ships, luggage, etc. The system comprises an X-ray source 1401. X-ray emitted from the X-ray source 1401 may backscatter from an object 1402 (e.g., shipping containers, vehicles, ships, etc.) and be projected to the image sensor 9000. Different internal structures of the object 1402 may

backscatter X-ray differently. The image sensor **9000** forms an image by detecting the intensity distribution of the backscattered X-ray and/or energies of the backscattered X-ray photons.

[0113] FIG. 19 schematically shows another cargo scanning or non-intrusive inspection (NII) system comprising an image sensor **9000** as described in relation to FIG. 4A-FIG. 15B. The system may be used for luggage screening at public transportation stations and airports. The system comprises an X-ray source **1501**. X-ray emitted from the X-ray source **1501** may penetrate a piece of luggage **1502**, be differently attenuated by the contents of the luggage, and projected to the image sensor **9000**. The image sensor **9000** forms an image by detecting the intensity distribution of the transmitted X-ray. The system may reveal contents of luggage and identify items forbidden on public transportation, such as firearms, narcotics, edged weapons, flammables.

[0114] FIG. 20 schematically shows a full-body scanner system comprising an image sensor **9000** as described in relation to FIG. 4A-FIG. 15B. The full-body scanner system may detect objects on a person's body for security screening purposes, without physically removing clothes or making physical contact. The full-body scanner system may be able to detect non-metal objects. The full-body scanner system comprises an X-ray source **1601**. X-ray emitted from the X-ray source **1601** may backscatter from a human **1602** being screened and objects thereon, and be projected to the image sensor **9000**. The objects and the human body may backscatter X-ray differently. The image sensor **9000** forms an image by detecting the intensity distribution of the backscattered X-ray. The image sensor **9000** and the X-ray source **1601** may be configured to scan the human in a linear or rotational direction.

[0115] FIG. 21 schematically shows an X-ray computed tomography (X-ray CT) system. The X-ray CT system uses computer-processed X-rays to produce tomographic images (virtual "slices") of specific areas of a scanned object. The tomographic images may be used for diagnostic and therapeutic purposes in various medical disciplines, or for flaw detection, failure analysis, metrology, assembly analysis and reverse engineering. The X-ray CT system comprises an image sensor **9000** as described in relation to FIG. 4A-FIG. 15B and an X-ray source **1701**. The image sensor **9000** and the X-ray source **1701** may be configured to rotate synchronously along one or more circular or spiral paths.

[0116] FIG. 22 schematically shows an electron microscope. The electron microscope comprises an electron source **1801** (also called an electron gun) that is configured to emit electrons. The electron source **1801** may have various emission mechanisms such as thermionic, photocathode, cold emission, or plasmas source. The emitted electrons pass through an electronic optical system **1803**, which may be configured to shape, accelerate, or focus the electrons. The electrons then reach a sample **1802** and an image detector may form an image therefrom. The electron microscope may comprise an image sensor **9000** as described in relation to FIG. 4A-FIG. 15B, for performing energy-dispersive X-ray spectroscopy (EDS). EDS is an analytical technique used for the elemental analysis or chemical characterization of a sample. When the electrons incident on a sample, they cause emission of characteristic X-rays from the sample. The incident electrons may excite an electron in an inner shell of an atom in the sample, ejecting it from the shell while creating an electron hole

where the electron was. An electron from an outer, higher-energy shell then fills the hole, and the difference in energy between the higher-energy shell and the lower energy shell may be released in the form of an X-ray. The number and energy of the X-rays emitted from the sample can be measured by the image sensor **9000**.

[0117] The image sensor **9000** described here may have other applications such as in an X-ray telescope, X-ray mammography, industrial X-ray defect detection, X-ray microscopy or microradiography, X-ray casting inspection, X-ray non-destructive testing, X-ray weld inspection, X-ray digital subtraction angiography, etc. It may be suitable to use this image sensor **9000** in place of a photographic plate, a photographic film, a PSP plate, an X-ray image intensifier, a scintillator, or another semiconductor X-ray detector.

[0118] FIG. 23A and FIG. 23B each show a component diagram of the electronic system **121**, according to an embodiment. The electronic system **121** may include a first voltage comparator **301**, a second voltage comparator **302**, a counter **320**, a switch **305**, a voltmeter **306** and a controller **310**.

[0119] The first voltage comparator **301** is configured to compare the voltage of an electrode of a diode **300** to a first threshold. The diode may be a diode formed by the first doped region **111**, one of the discrete regions **114** of the second doped region **113**, and the optional intrinsic region **112**. Alternatively, the first voltage comparator **301** is configured to compare the voltage of an electrical contact (e.g., a discrete portion of electrical contact **119B**) to a first threshold. The first voltage comparator **301** may be configured to monitor the voltage directly, or calculate the voltage by integrating an electric current flowing through the diode or electrical contact over a period of time. The first voltage comparator **301** may be controllably activated or deactivated by the controller **310**. The first voltage comparator **301** may be a continuous comparator. Namely, the first voltage comparator **301** may be configured to be activated continuously, and monitor the voltage continuously. The first voltage comparator **301** configured as a continuous comparator reduces the chance that the system **121** misses signals generated by an incident X-ray photon. The first voltage comparator **301** configured as a continuous comparator is especially suitable when the incident X-ray intensity is relatively high. The first voltage comparator **301** may be a clocked comparator, which has the benefit of lower power consumption. The first voltage comparator **301** configured as a clocked comparator may cause the system **121** to miss signals generated by some incident X-ray photons. When the incident X-ray intensity is low, the chance of missing an incident X-ray photon is low because the time interval between two successive photons is relatively long. Therefore, the first voltage comparator **301** configured as a clocked comparator is especially suitable when the incident X-ray intensity is relatively low. The first threshold may be 5-10%, 10%-20%, 20-30%, 30-40% or 40-50% of the maximum voltage one incident X-ray photon may generate in the diode or the resistor. The maximum voltage may depend on the energy of the incident X-ray photon (i.e., the wavelength of the incident X-ray), the material of the X-ray absorption layer **110**, and other factors. For example, the first threshold may be 50 mV, 100 mV, 150 mV, or 200 mV.

[0120] The second voltage comparator **302** is configured to compare the voltage to a second threshold. The second voltage comparator **302** may be configured to monitor the

voltage directly, or calculate the voltage by integrating an electric current flowing through the diode or the electrical contact over a period of time. The second voltage comparator **302** may be a continuous comparator. The second voltage comparator **302** may be controllably activate or deactivated by the controller **310**. When the second voltage comparator **302** is deactivated, the power consumption of the second voltage comparator **302** may be less than 1%, less than 5%, less than 10% or less than 20% of the power consumption when the second voltage comparator **302** is activated. The absolute value of the second threshold is greater than the absolute value of the first threshold. As used herein, the term “absolute value” or “modulus” $|x|$ of a real number x is the non-negative value of x without regard to its sign. Namely,

$$|x| = \begin{cases} x, & \text{if } x \geq 0 \\ -x, & \text{if } x \leq 0 \end{cases}$$

The second threshold may be 200%-300% of the first threshold. The second threshold may be at least 50% of the maximum voltage one incident X-ray photon may generate in the diode or resistor. For example, the second threshold may be 100 mV, 150 mV, 200 mV, 250 mV or 300 mV. The second voltage comparator **302** and the first voltage comparator **310** may be the same component. Namely, the system **121** may have one voltage comparator that can compare a voltage with two different thresholds at different times.

[0121] The first voltage comparator **301** or the second voltage comparator **302** may include one or more op-amps or any other suitable circuitry. The first voltage comparator **301** or the second voltage comparator **302** may have a high speed to allow the system **121** to operate under a high flux of incident X-ray. However, having a high speed is often at the cost of power consumption.

[0122] The counter **320** is configured to register a number of X-ray photons reaching the diode or resistor. The counter **320** may be a software component (e.g., a number stored in a computer memory) or a hardware component (e.g., a 4017 IC and a 7490 IC).

[0123] The controller **310** may be a hardware component such as a microcontroller and a microprocessor. The controller **310** is configured to start a time delay from a time at which the first voltage comparator **301** determines that the absolute value of the voltage equals or exceeds the absolute value of the first threshold (e.g., the absolute value of the voltage increases from below the absolute value of the first threshold to a value equal to or above the absolute value of the first threshold). The absolute value is used here because the voltage may be negative or positive, depending on whether the voltage of the cathode or the anode of the diode or which electrical contact is used. The controller **310** may be configured to keep deactivated the second voltage comparator **302**, the counter **320** and any other circuits the operation of the first voltage comparator **301** does not require, before the time at which the first voltage comparator **301** determines that the absolute value of the voltage equals or exceeds the absolute value of the first threshold. The time delay may expire before or after the voltage becomes stable, i.e., the rate of change of the voltage is substantially zero. The phase “the rate of change of the voltage is substantially zero” means that temporal change of the voltage is less than

0.1%/ns. The phase “the rate of change of the voltage is substantially non-zero” means that temporal change of the voltage is at least 0.1%/ns.

[0124] The controller **310** may be configured to activate the second voltage comparator during (including the beginning and the expiration) the time delay. In an embodiment, the controller **310** is configured to activate the second voltage comparator at the beginning of the time delay. The term “activate” means causing the component to enter an operational state (e.g., by sending a signal such as a voltage pulse or a logic level, by providing power, etc.). The term “deactivate” means causing the component to enter a non-operational state (e.g., by sending a signal such as a voltage pulse or a logic level, by cut off power, etc.). The operational state may have higher power consumption (e.g., 10 times higher, 100 times higher, 1000 times higher) than the non-operational state. The controller **310** itself may be deactivated until the output of the first voltage comparator **301** activates the controller **310** when the absolute value of the voltage equals or exceeds the absolute value of the first threshold.

[0125] The controller **310** may be configured to cause the number registered by the counter **320** to increase by one, if, during the time delay, the second voltage comparator **302** determines that the absolute value of the voltage equals or exceeds the absolute value of the second threshold.

[0126] The controller **310** may be configured to cause the voltmeter **306** to measure the voltage upon expiration of the time delay. The controller **310** may be configured to connect the electrode to an electrical ground, so as to reset the voltage and discharge any charge carriers accumulated on the electrode. In an embodiment, the electrode is connected to an electrical ground after the expiration of the time delay. In an embodiment, the electrode is connected to an electrical ground for a finite reset time period. The controller **310** may connect the electrode to the electrical ground by controlling the switch **305**. The switch may be a transistor such as a field-effect transistor (FET).

[0127] In an embodiment, the system **121** has no analog filter network (e.g., a RC network). In an embodiment, the system **121** has no analog circuitry.

[0128] The voltmeter **306** may feed the voltage it measures to the controller **310** as an analog or digital signal.

[0129] The system **121** may include a capacitor module **309** electrically connected to the electrode of the diode **300** or which electrical contact, wherein the capacitor module is configured to collect charge carriers from the electrode. The capacitor module can include a capacitor in the feedback path of an amplifier. The amplifier configured as such is called a capacitive transimpedance amplifier (CTIA). CTIA has high dynamic range by keeping the amplifier from saturating and improves the signal-to-noise ratio by limiting the bandwidth in the signal path. Charge carriers from the electrode accumulate on the capacitor over a period of time (“integration period”) (e.g., as shown in FIG. **24**, between t_0 to t_1 , or t_1 - t_2). After the integration period has expired, the capacitor voltage is sampled and then reset by a reset switch. The capacitor module can include a capacitor directly connected to the electrode.

[0130] FIG. **24** schematically shows a temporal change of the electric current flowing through the electrode (upper curve) caused by charge carriers generated by an X-ray photon incident on the diode or the resistor, and a corresponding temporal change of the voltage of the electrode

(lower curve). The voltage may be an integral of the electric current with respect to time. At time t_0 , the X-ray photon hits the diode or the resistor, charge carriers start being generated in the diode or the resistor, electric current starts to flow through the electrode of the diode or the resistor, and the absolute value of the voltage of the electrode or electrical contact starts to increase. At time t_1 , the first voltage comparator 301 determines that the absolute value of the voltage equals or exceeds the absolute value of the first threshold $V1$, and the controller 310 starts the time delay TD1 and the controller 310 may deactivate the first voltage comparator 301 at the beginning of TD1. If the controller 310 is deactivated before t_1 , the controller 310 is activated at t_1 . During TD1, the controller 310 activates the second voltage comparator 302. The term “during” a time delay as used here means the beginning and the expiration (i.e., the end) and any time in between. For example, the controller 310 may activate the second voltage comparator 302 at the expiration of TD1. If during TD1, the second voltage comparator 302 determines that the absolute value of the voltage equals or exceeds the absolute value of the second threshold at time t_2 , the controller 310 causes the number registered by the counter 320 to increase by one. At time t_e , all charge carriers generated by the X-ray photon drift out of the X-ray absorption layer 110. At time t_s , the time delay TD1 expires. In the example of FIG. 24, time t_s is after time t_e ; namely TD1 expires after all charge carriers generated by the X-ray photon drift out of the X-ray absorption layer 110. The rate of change of the voltage is thus substantially zero at t_s . The controller 310 may be configured to deactivate the second voltage comparator 302 at expiration of TD1 or at t_2 , or any time in between.

[0131] The controller 310 may be configured to cause the voltmeter 306 to measure the voltage upon expiration of the time delay TD1. In an embodiment, the controller 310 causes the voltmeter 306 to measure the voltage after the rate of change of the voltage becomes substantially zero after the expiration of the time delay TD1. The voltage at this moment is proportional to the amount of charge carriers generated by an X-ray photon, which relates to the energy of the X-ray photon. The controller 310 may be configured to determine the energy of the X-ray photon based on voltage the voltmeter 306 measures. One way to determine the energy is by binning the voltage. The counter 320 may have a sub-counter for each bin. When the controller 310 determines that the energy of the X-ray photon falls in a bin, the controller 310 may cause the number registered in the sub-counter for that bin to increase by one. Therefore, the system 121 may be able to detect an X-ray image and may be able to resolve X-ray photon energies of each X-ray photon.

[0132] After TD1 expires, the controller 310 connects the electrode to an electric ground for a reset period RST to allow charge carriers accumulated on the electrode to flow to the ground and reset the voltage. After RST, the system 121 is ready to detect another incident X-ray photon. Implicitly, the rate of incident X-ray photons the system 121 can handle in the example of FIG. 24 is limited by $1/(TD1+RST)$. If the first voltage comparator 301 has been deactivated, the controller 310 can activate it at any time before RST expires. If the controller 310 has been deactivated, it may be activated before RST expires.

[0133] FIG. 25 schematically shows a temporal change of the electric current flowing through the electrode (upper

curve) caused by noise (e.g., dark current, background radiation, scattered X-rays, fluorescent X-rays, shared charges from adjacent pixels), and a corresponding temporal change of the voltage of the electrode (lower curve), in the system 121 operating in the way shown in FIG. 24. At time t_0 , the noise begins. If the noise is not large enough to cause the absolute value of the voltage to exceed the absolute value of $V1$, the controller 310 does not activate the second voltage comparator 302. If the noise is large enough to cause the absolute value of the voltage to exceed the absolute value of $V1$ at time t_1 as determined by the first voltage comparator 301, the controller 310 starts the time delay TD1 and the controller 310 may deactivate the first voltage comparator 301 at the beginning of TD1. During TD1 (e.g., at expiration of TD1), the controller 310 activates the second voltage comparator 302. The noise is very unlikely large enough to cause the absolute value of the voltage to exceed the absolute value of $V2$ during TD1. Therefore, the controller 310 does not cause the number registered by the counter 320 to increase. At time t_e , the noise ends. At time t_s , the time delay TD1 expires. The controller 310 may be configured to deactivate the second voltage comparator 302 at expiration of TD1. The controller 310 may be configured not to cause the voltmeter 306 to measure the voltage if the absolute value of the voltage does not exceed the absolute value of $V2$ during TD1. After TD1 expires, the controller 310 connects the electrode to an electric ground for a reset period RST to allow charge carriers accumulated on the electrode as a result of the noise to flow to the ground and reset the voltage. Therefore, the system 121 may be very effective in noise rejection.

[0134] FIG. 26 schematically shows a temporal change of the electric current flowing through the electrode (upper curve) caused by charge carriers generated by an X-ray photon incident on the diode or the resistor, and a corresponding temporal change of the voltage of the electrode (lower curve), when the system 121 operates to detect incident X-ray photons at a rate higher than $1/(TD1+RST)$. The voltage may be an integral of the electric current with respect to time. At time t_0 , the X-ray photon hits the diode or the resistor, charge carriers start being generated in the diode or the resistor, electric current starts to flow through the electrode of the diode or the electrical contact of resistor, and the absolute value of the voltage of the electrode or the electrical contact starts to increase. At time t_1 , the first voltage comparator 301 determines that the absolute value of the voltage equals or exceeds the absolute value of the first threshold $V1$, and the controller 310 starts a time delay TD2 shorter than TD1, and the controller 310 may deactivate the first voltage comparator 301 at the beginning of TD2. If the controller 310 is deactivated before t_1 , the controller 310 is activated at t_1 . During TD2 (e.g., at expiration of TD2), the controller 310 activates the second voltage comparator 302. If during TD2, the second voltage comparator 302 determines that the absolute value of the voltage equals or exceeds the absolute value of the second threshold at time t_2 , the controller 310 causes the number registered by the counter 320 to increase by one. At time t_e , all charge carriers generated by the X-ray photon drift out of the X-ray absorption layer 110. At time t_b , the time delay TD2 expires. In the example of FIG. 26, time t_b is before time t_e ; namely TD2 expires before all charge carriers generated by the X-ray photon drift out of the X-ray absorption layer 110. The rate of change of the voltage is thus

substantially non-zero at t_n . The controller 310 may be configured to deactivate the second voltage comparator 302 at expiration of TD2 or at t_2 , or any time in between.

[0135] The controller 310 may be configured to extrapolate the voltage at t_e from the voltage as a function of time during TD2 and use the extrapolated voltage to determine the energy of the X-ray photon.

[0136] After TD2 expires, the controller 310 connects the electrode to an electric ground for a reset period RST to allow charge carriers accumulated on the electrode to flow to the ground and reset the voltage. In an embodiment, RST expires before t_e . The rate of change of the voltage after RST may be substantially non-zero because all charge carriers generated by the X-ray photon have not drifted out of the X-ray absorption layer 110 upon expiration of RST before t_e . The rate of change of the voltage becomes substantially zero after t_e and the voltage stabilized to a residue voltage VR after t_e . In an embodiment, RST expires at or after t_e , and the rate of change of the voltage after RST may be substantially zero because all charge carriers generated by the X-ray photon drift out of the X-ray absorption layer 110 at t_e . After RST, the system 121 is ready to detect another incident X-ray photon. If the first voltage comparator 301 has been deactivated, the controller 310 can activate it at any time before RST expires. If the controller 310 has been deactivated, it may be activated before RST expires.

[0137] FIG. 27 schematically shows a temporal change of the electric current flowing through the electrode (upper curve) caused by noise (e.g., dark current, background radiation, scattered X-rays, fluorescent X-rays, shared charges from adjacent pixels), and a corresponding temporal change of the voltage of the electrode (lower curve), in the system 121 operating in the way shown in FIG. 26. At time t_0 , the noise begins. If the noise is not large enough to cause the absolute value of the voltage to exceed the absolute value of V1, the controller 310 does not activate the second voltage comparator 302. If the noise is large enough to cause the absolute value of the voltage to exceed the absolute value of V1 at time t_1 as determined by the first voltage comparator 301, the controller 310 starts the time delay TD2 and the controller 310 may deactivate the first voltage comparator 301 at the beginning of TD2. During TD2 (e.g., at expiration of TD2), the controller 310 activates the second voltage comparator 302. The noise is very unlikely large enough to cause the absolute value of the voltage to exceed the absolute value of V2 during TD2. Therefore, the controller 310 does not cause the number registered by the counter 320 to increase. At time t_e , the noise ends. At time t_n , the time delay TD2 expires. The controller 310 may be configured to deactivate the second voltage comparator 302 at expiration of TD2. After TD2 expires, the controller 310 connects the electrode to an electric ground for a reset period RST to allow charge carriers accumulated on the electrode as a result of the noise to flow to the ground and reset the voltage. Therefore, the system 121 may be very effective in noise rejection.

[0138] FIG. 28 schematically shows a temporal change of the electric current flowing through the electrode (upper curve) caused by charge carriers generated by a series of X-ray photons incident on the diode or the resistor, and a corresponding temporal change of the voltage of the electrode (lower curve), in the system 121 operating in the way shown in FIG. 26 with RST expires before t_e . The voltage curve caused by charge carriers generated by each incident

X-ray photon is offset by the residue voltage before that photon. The absolute value of the residue voltage successively increases with each incident photon. When the absolute value of the residue voltage exceeds V1 (see the dotted rectangle in FIG. 28), the controller starts the time delay TD2 and the controller 310 may deactivate the first voltage comparator 301 at the beginning of TD2. If no other X-ray photon incidence on the diode or the resistor during TD2, the controller connects the electrode to the electrical ground during the reset time period RST at the end of TD2, thereby resetting the residue voltage. The residue voltage thus does not cause an increase of the number registered by the counter 320.

[0139] While various aspects and embodiments have been disclosed herein, other aspects and embodiments will be apparent to those skilled in the art. The various aspects and embodiments disclosed herein are for purposes of illustration and are not intended to be limiting, with the true scope and spirit being indicated by the following claims.

What is claimed is:

1. An image sensor comprising:
 - a plurality of packages arranged in a plurality of layers; wherein each of the packages comprises an X-ray detector mounted on a printed circuit board (PCB); wherein the packages are mounted on one or more system PCBs; wherein within an area encompassing a plurality of the X-ray detectors in the plurality of packages, a dead zone of the packages in each of the plurality of layers is shadowed by the packages in the other layers; wherein the packages in at least one of the layers are arranged in rows; wherein the packages in at least one of the rows partially overlap with one another.
2. The image sensor of claim 1, wherein the packages are parallel to the one or more system PCBs.
3. The image sensor of claim 1, wherein the packages are tilted relative to the one or more system PCBs.
4. The image sensor of claim 1, wherein among the packages in that row, a part of a dead zone of one package is shadowed by its neighboring package.
5. The image sensor of claim 1, wherein the packages in different layers are mounted on different system PCBs.
6. The image sensor of claim 1, wherein the packages are arranged such that light incident in the area is detectable by at least one of the packages.
7. The image sensor of claim 1, wherein the packages are arranged such that light incident in the area is detectable by at least two of the packages.
8. The image sensor of claim 1, wherein at least some of the packages each comprise multiple X-ray detectors mounted on the PCB.
9. The image sensor of claim 1, wherein the X-ray detector of at least one package comprises a perimeter zone wherein light incident in the perimeter zone is not detectable by the X-ray detector.
10. The image sensor of claim 1, wherein the packages are mounted on the one or more system PCBs by wire bonding.
11. The image sensor of claim 1, wherein the packages are rectangular in shape.
12. The image sensor of claim 1, wherein the packages are hexagonal in shape.

13. The image sensor of claim 1, wherein the packages are mounted on the one or more system PCBs by plugs and receptacles.

14. The image sensor of claim 1, wherein the packages are mounted on the one or more system PCBs by plugs, spacers and receptacles.

15. The image sensor of claim 1, wherein the X-ray detector of at least one of the packages comprises an X-ray absorption layer and an electronics layer;

wherein the X-ray absorption layer comprises an electrode;

wherein the electronics layer comprises an electronics system;

wherein the electronics system comprises:

a first voltage comparator configured to compare a voltage of the electrode to a first threshold;

a second voltage comparator configured to compare the voltage to a second threshold;

a counter configured to register a number of X-ray photons reaching the X-ray absorption layer;

a controller;

wherein the controller is configured to start a time delay from a time at which the first voltage comparator determines that an absolute value of the voltage equals or exceeds an absolute value of the first threshold;

wherein the controller is configured to activate the second voltage comparator during the time delay;

wherein the controller is configured to cause the number registered by the counter to increase by one, if the

second voltage comparator determines that an absolute value of the voltage equals or exceeds an absolute value of the second threshold.

16. The image sensor of claim 15, wherein the electronics system further comprises a capacitor module electrically connected to the electrode, wherein the capacitor module is configured to collect charge carriers from the electrode.

17. The image sensor of claim 15, wherein the controller is configured to activate the second voltage comparator at a beginning or expiration of the time delay.

18. The image sensor of claim 15, wherein the electronics system further comprises a voltmeter, wherein the controller is configured to cause the voltmeter to measure the voltage upon expiration of the time delay.

19. The image sensor of claim 15, wherein the controller is configured to determine an X-ray photon energy based on a value of the voltage measured upon expiration of the time delay.

20. The image sensor of claim 15, wherein the controller is configured to connect the electrode to an electrical ground.

21. The image sensor of claim 15, wherein a rate of change of the voltage is substantially zero at expiration of the time delay.

22. The image sensor of claim 15, wherein a rate of change of the voltage is substantially non-zero at expiration of the time delay.

23. A system comprising the image sensor of claim 1 and an X-ray source.

* * * * *