



US 20200263723A1

(19) **United States**

(12) **Patent Application Publication**

Hudson et al.

(10) **Pub. No.: US 2020/0263723 A1**

(43) **Pub. Date: Aug. 20, 2020**

(54) **THREADED TRUSS FOUNDATIONS AND RELATED SYSTEMS, METHODS AND MACHINES**

on Oct. 29, 2018, provisional application No. 62/756,028, filed on Nov. 5, 2018.

(71) Applicant: **Ojjo, Inc.**, San Rafael, CA (US)

(72) Inventors: **Tyrus Hudson**, Petaluma, CA (US);
Charles Almy, Berkeley, CA (US);
Jack West, San Rafael, CA (US)

(21) Appl. No.: **16/867,268**

(22) Filed: **May 5, 2020**

Publication Classification

(51) **Int. Cl.**
F16B 25/00 (2006.01)
F16B 19/10 (2006.01)
(52) **U.S. Cl.**
CPC *F16B 25/0026* (2013.01); *F16B 25/0094*
(2013.01); *F24S 30/425* (2018.05); *F16B 25/0084* (2013.01); *F16B 25/00* (2013.01);
F16B 19/1045 (2013.01)

Related U.S. Application Data

(63) Continuation of application No. 16/416,022, filed on May 17, 2019, now Pat. No. 10,697,490.
(60) Provisional application No. 62/702,879, filed on Jul. 24, 2018, provisional application No. 62/718,780, filed on Aug. 14, 2018, provisional application No. 62/726,909, filed on Sep. 4, 2018, provisional application No. 62/733,273, filed on Sep. 19, 2018, provisional application No. 62/748,083, filed on Oct. 19, 2018, provisional application No. 62/752,197, filed

(57) **ABSTRACT**

A screw anchor for a trussed foundation system to support single-axis trackers and other structures and related methods of driving such a screw anchor into underlying ground. A hollowed tube of uniform diameter is open at both ends with a thread form beginning at one end and circumscribing a portion the tube, the thread form having a tapered lead-in. The open-ended geometry allows a mandrel or rock drill to be inserted and operated through the anchor during driving to expedite the driving process. The tapered thread form provides a lead-in for driving the anchor into a rock bore.

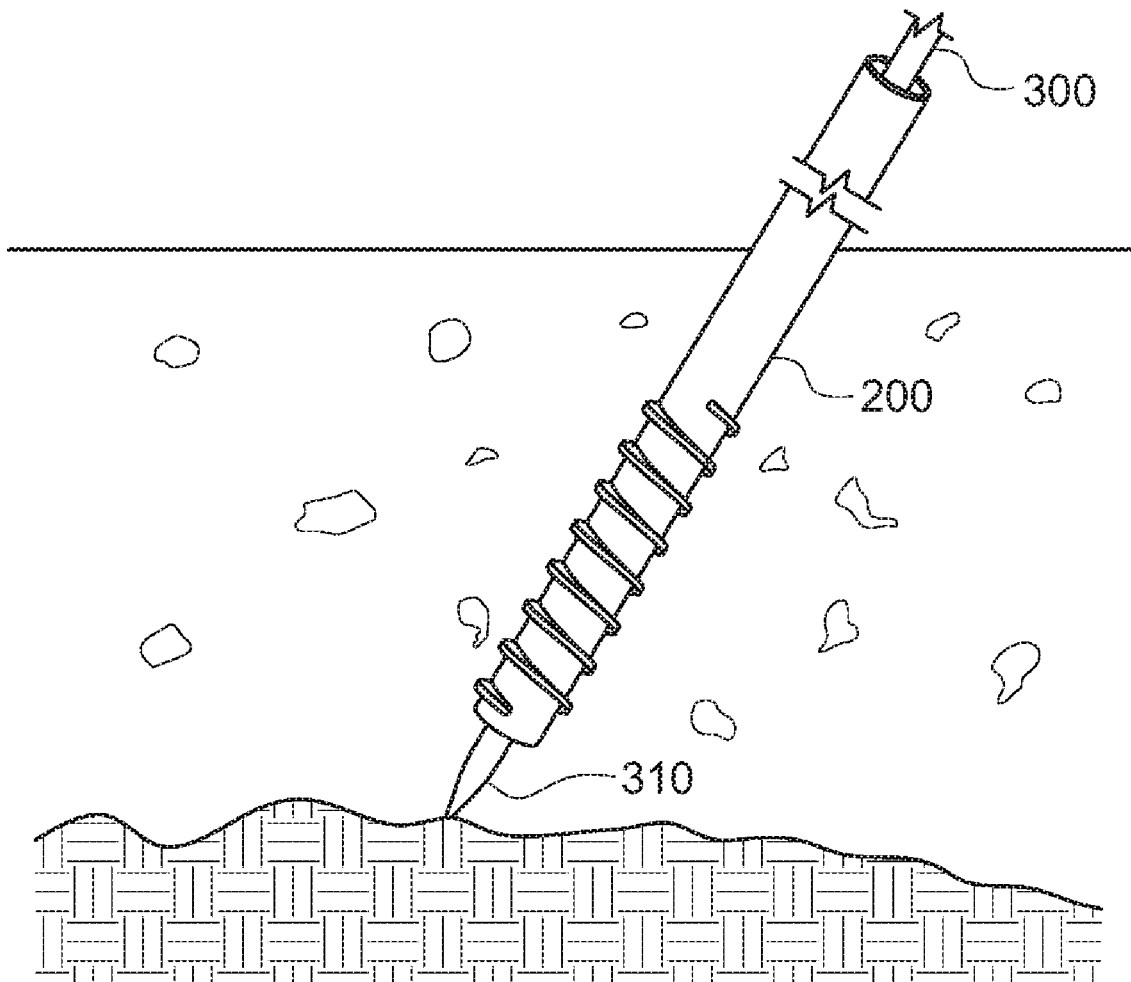

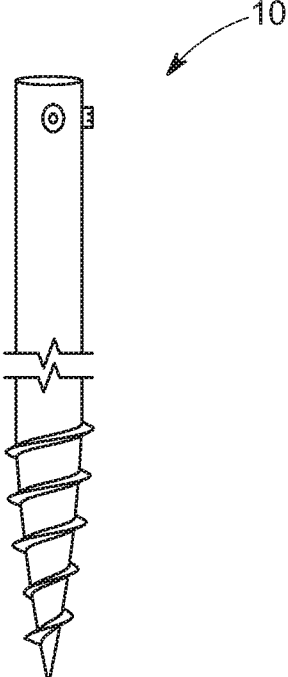

FIG. 1A
PRIOR ART

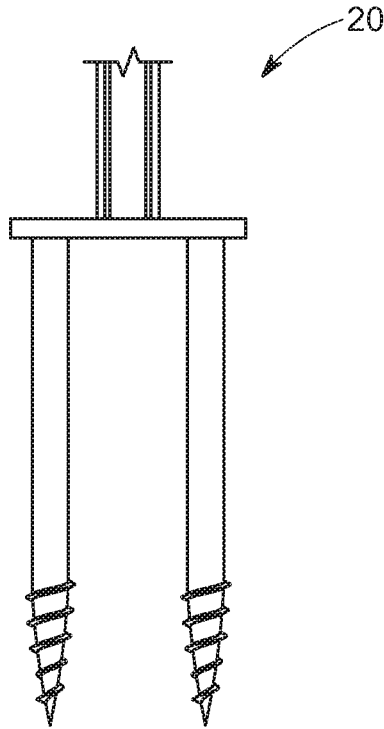

FIG. 1B
PRIOR ART

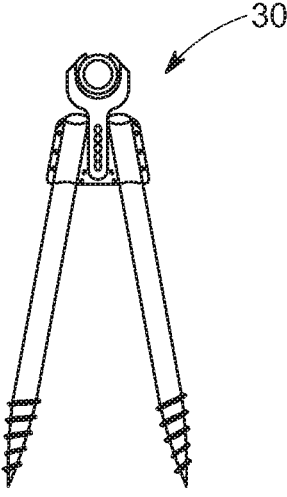

FIG. 1C
PRIOR ART

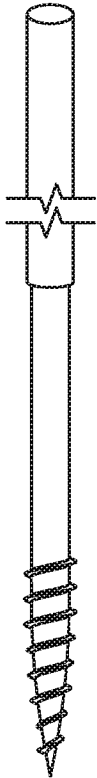

FIG. 2A

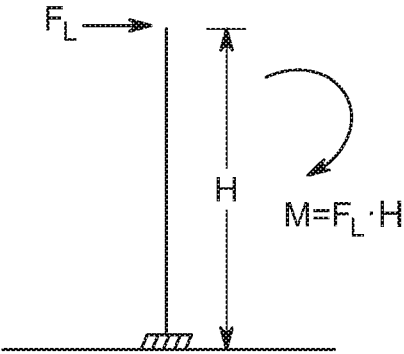

FIG. 2B

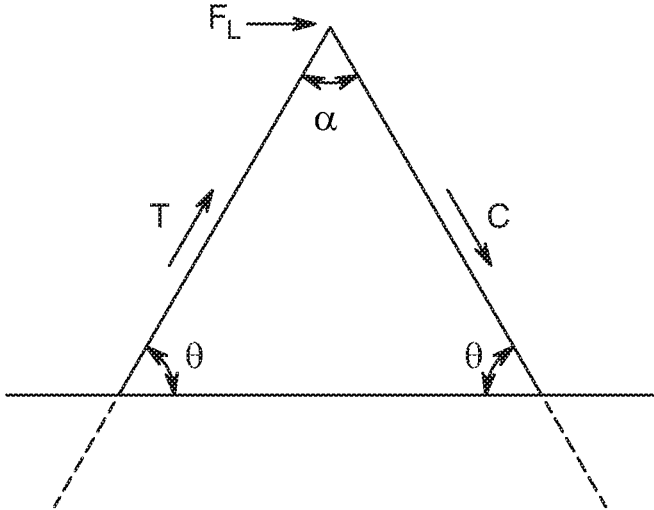

FIG. 2C

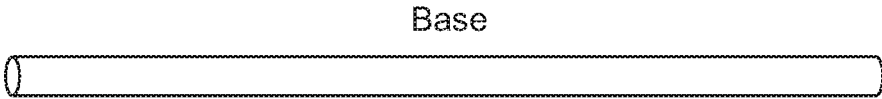

FIG. 3A

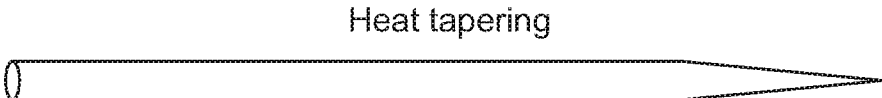

FIG. 3B

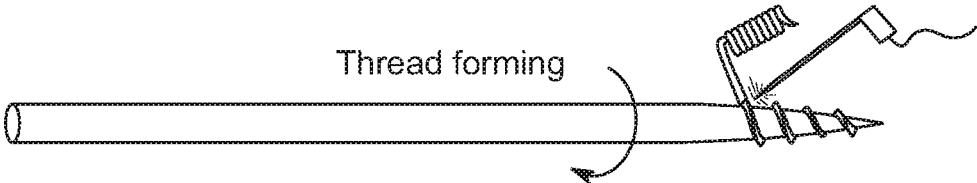

FIG. 3C



FIG. 3D

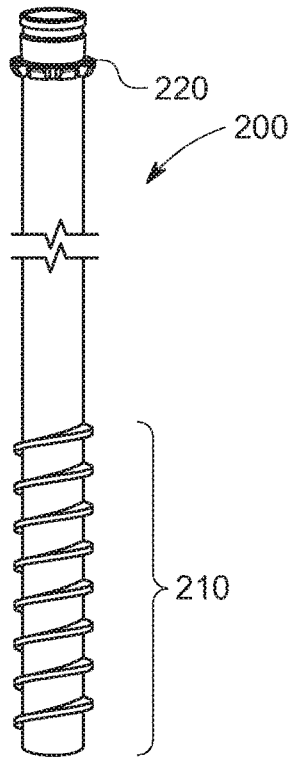

FIG. 4A

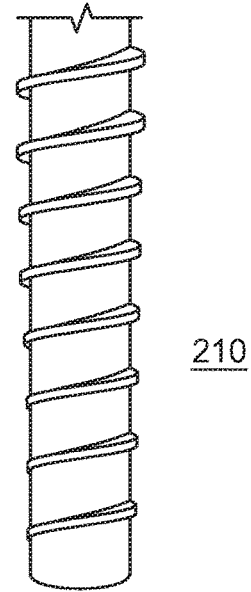

FIG. 4B

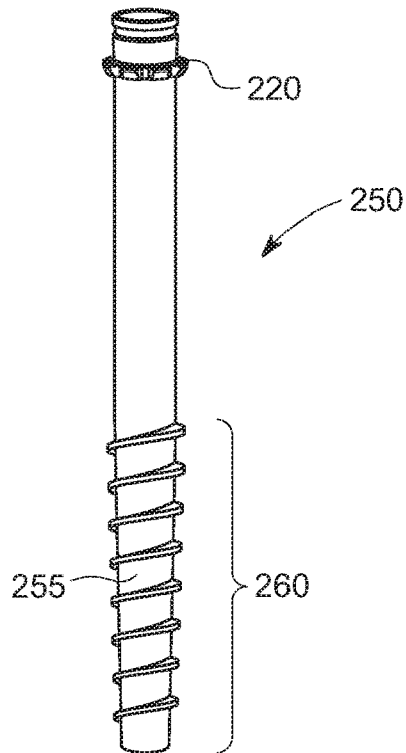

FIG. 4C

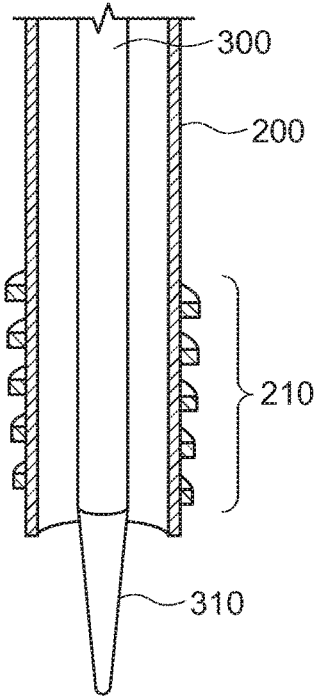

FIG. 5A

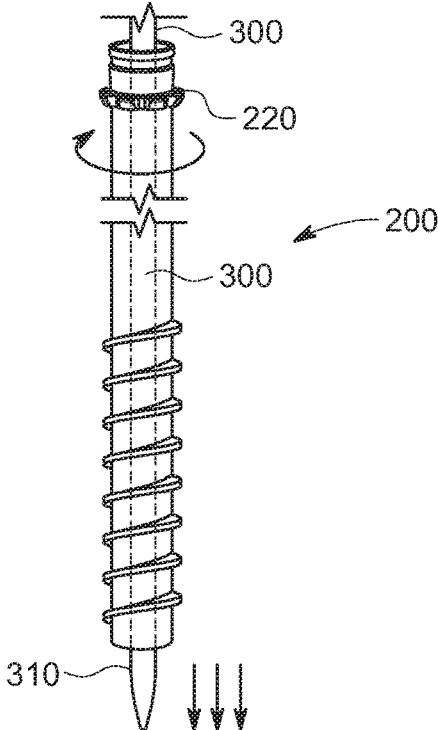

FIG. 5B

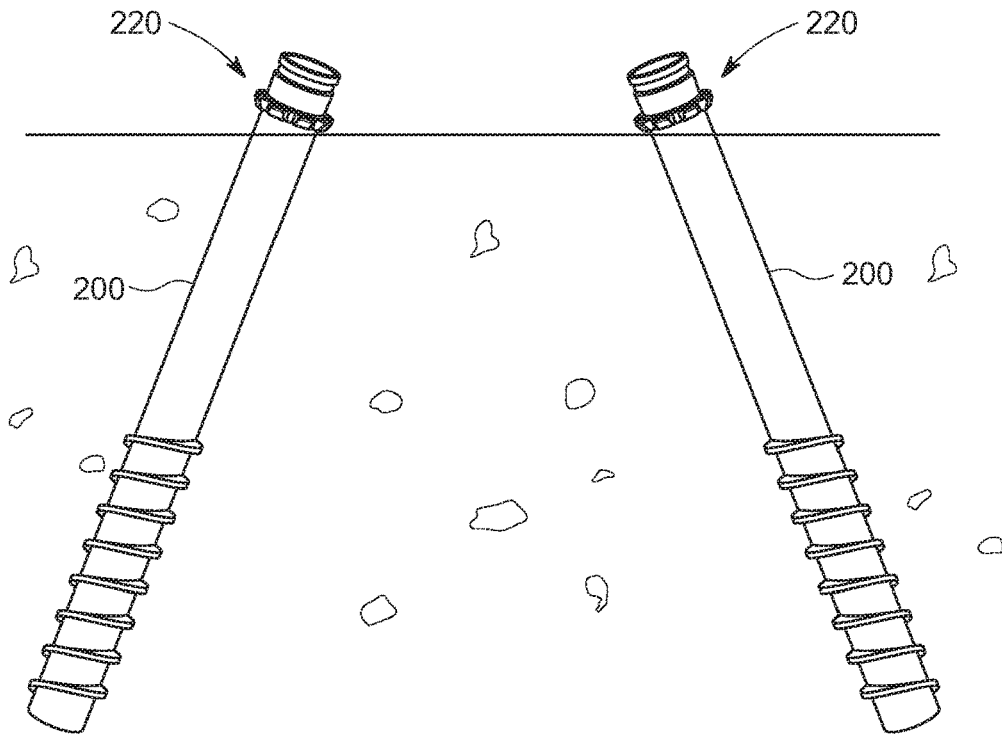

FIG. 6A

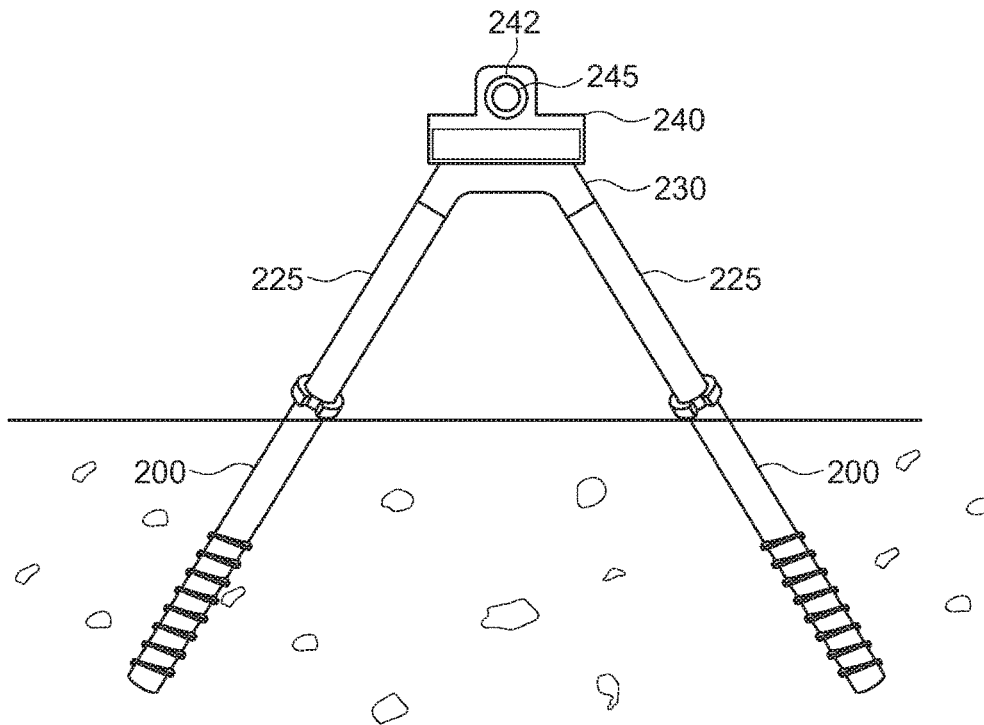

FIG. 6B

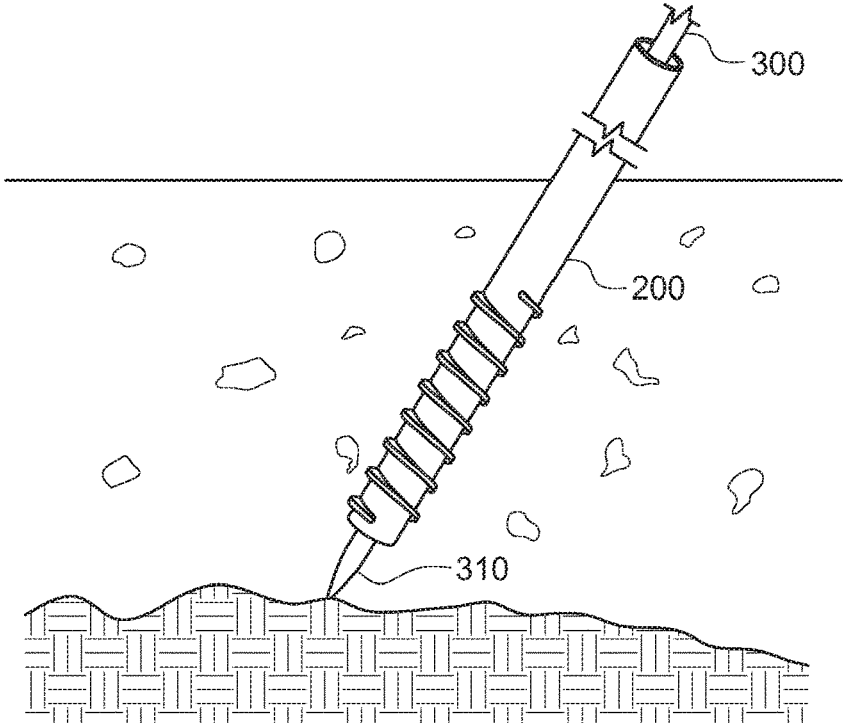

FIG. 7A

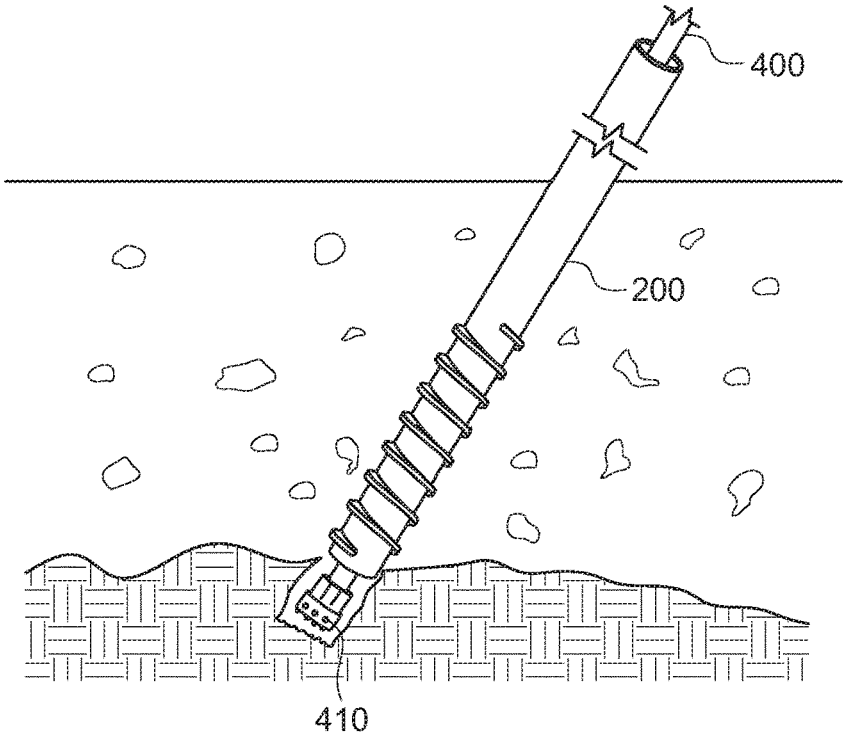

FIG. 7B

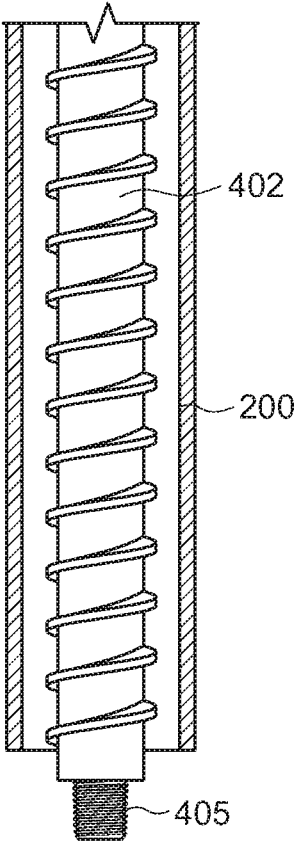

FIG. 8

410A

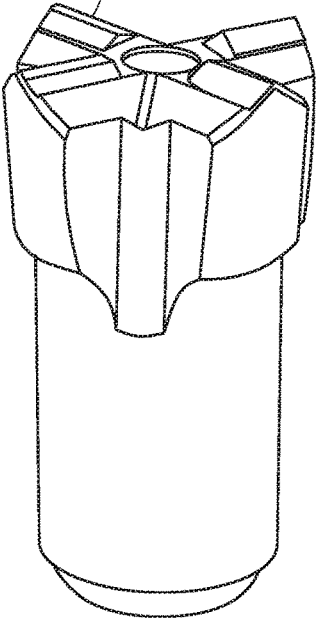

FIG. 9A

410B

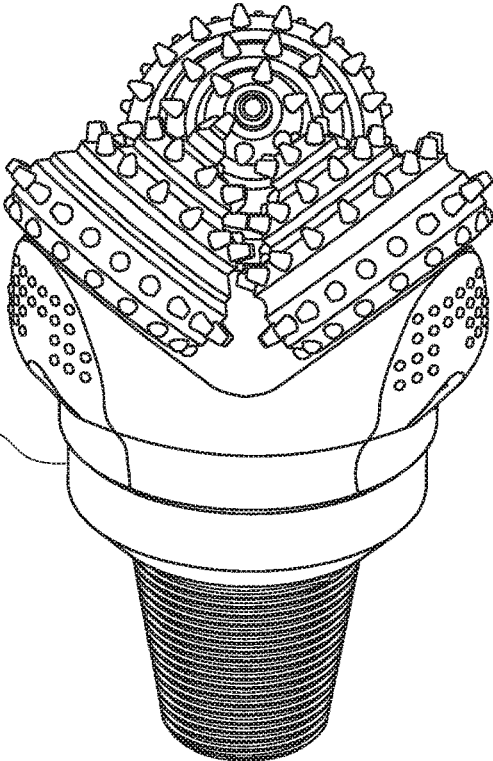

FIG. 9B

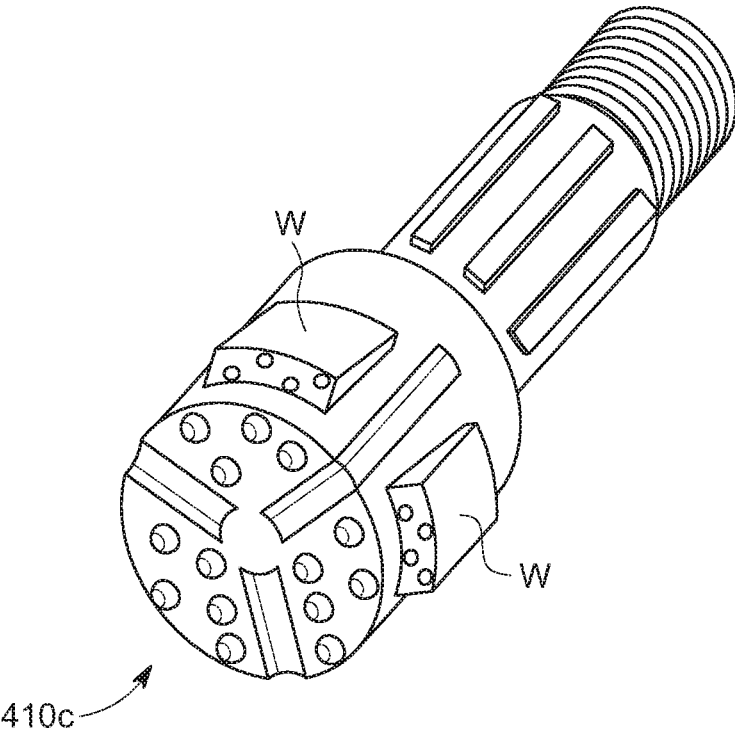

FIG. 9C

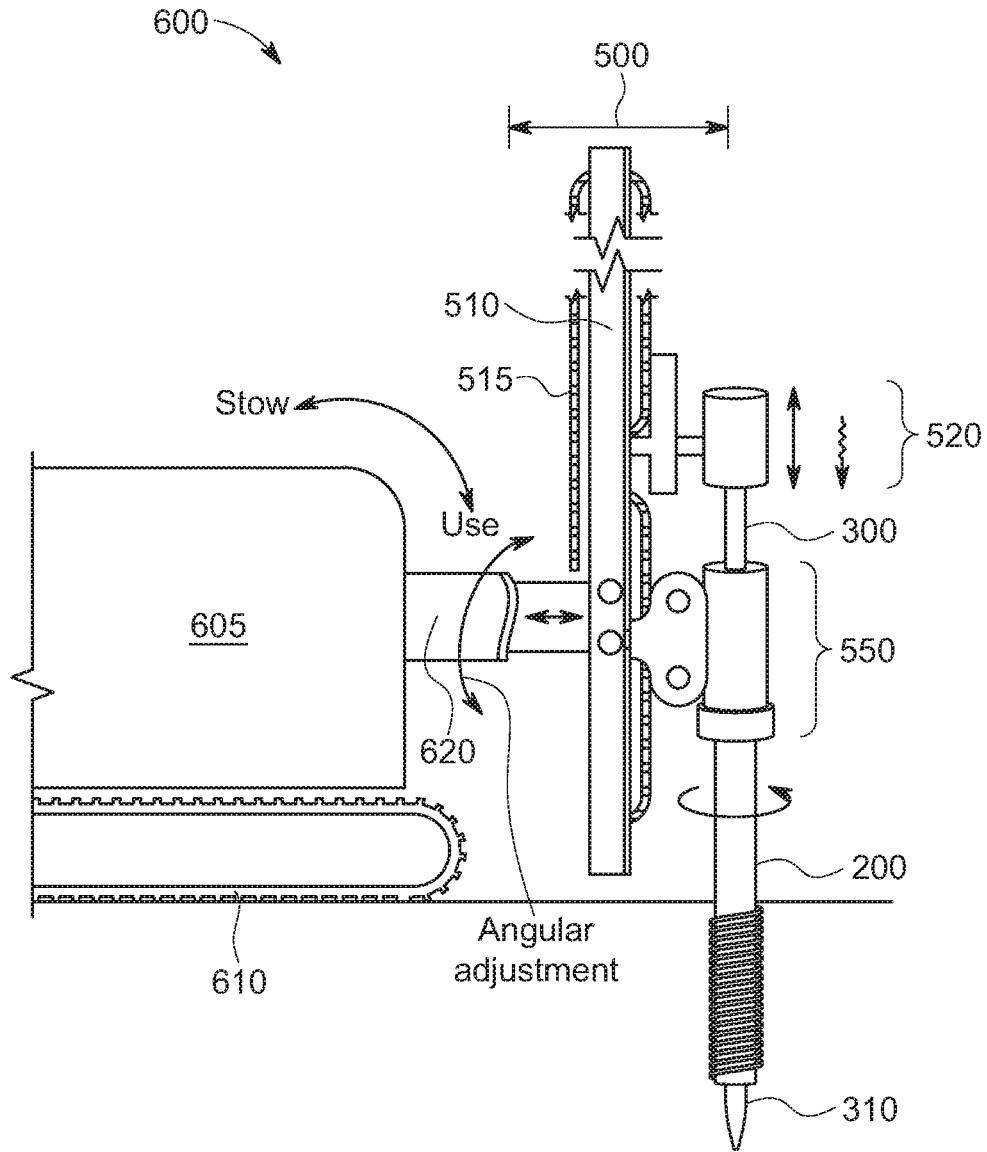

FIG. 10A

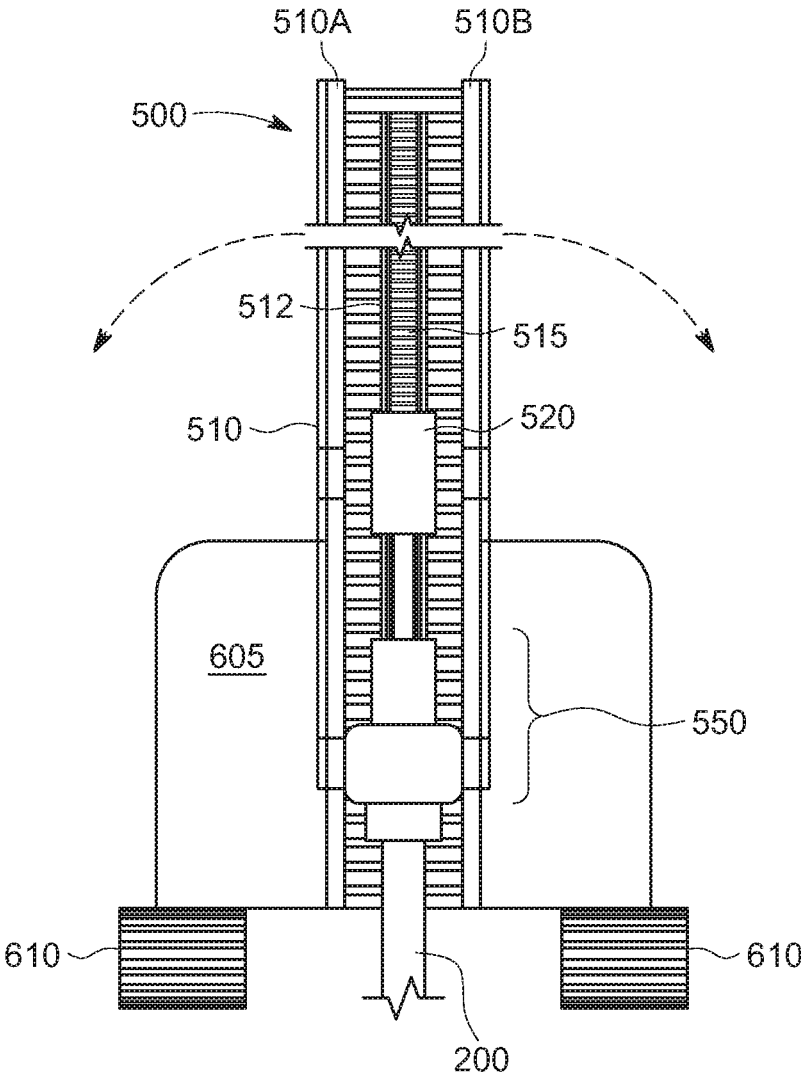

FIG. 10B

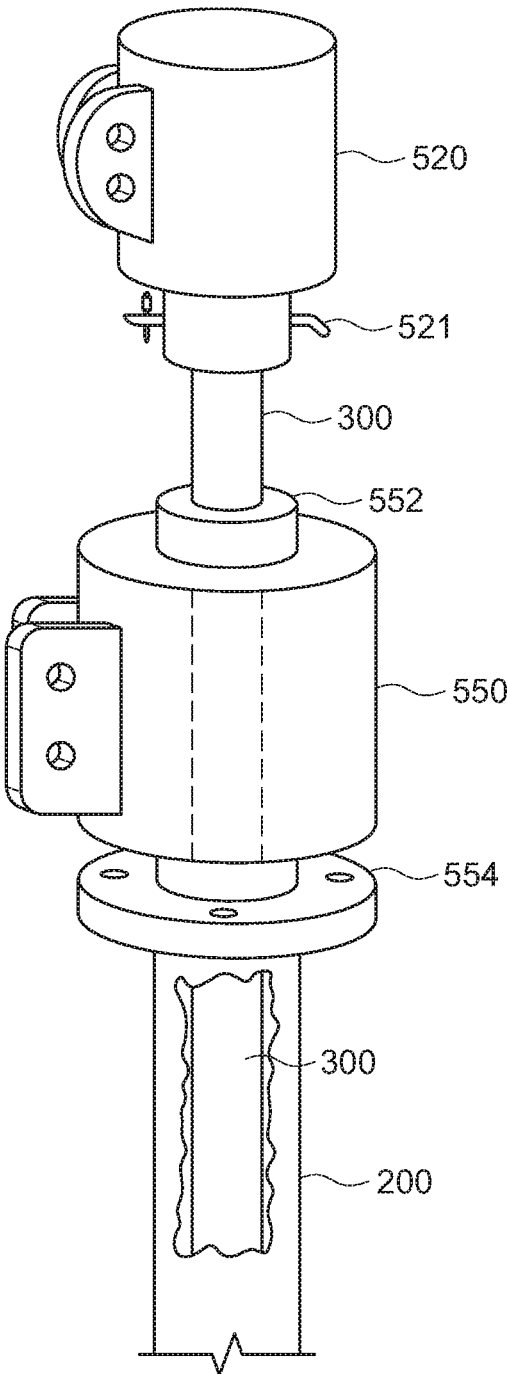

FIG. 11

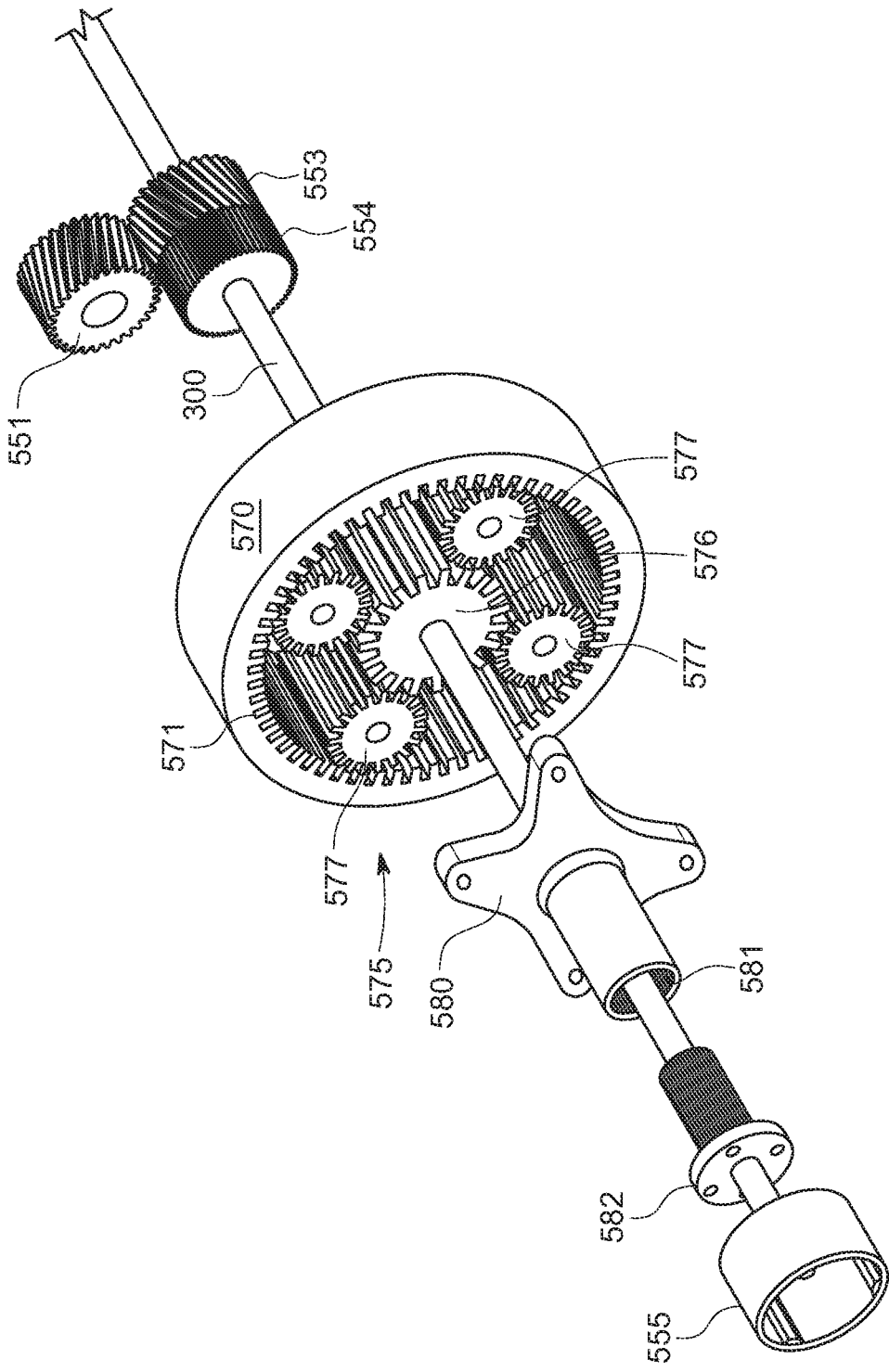

FIG. 12

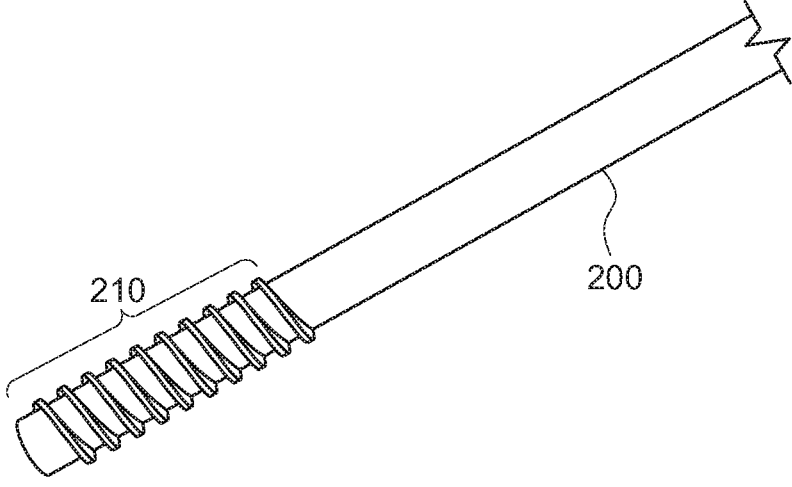

FIG. 13

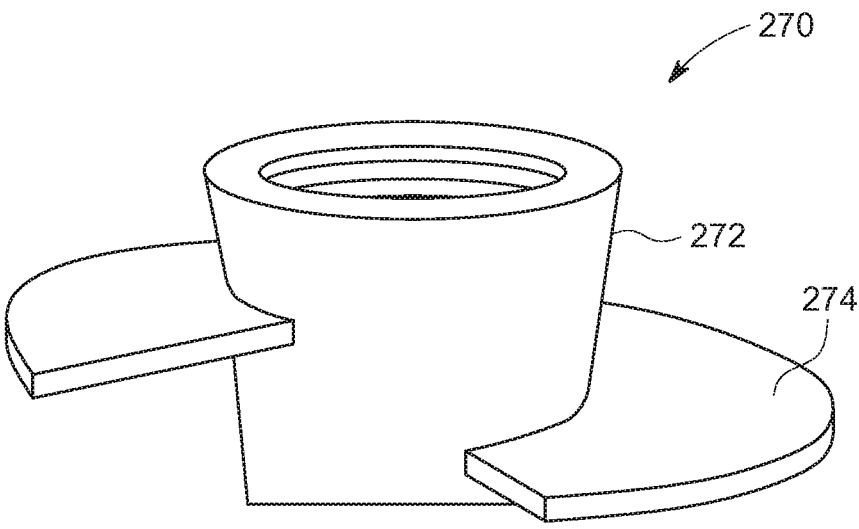

FIG. 14A

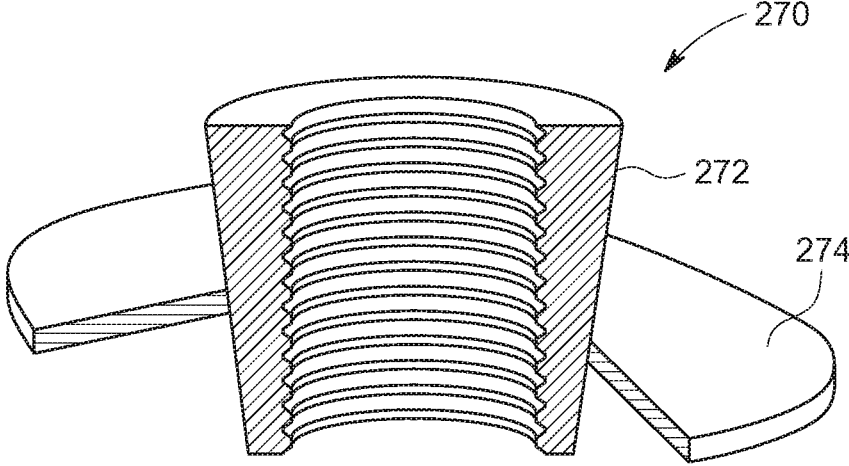

FIG. 14B

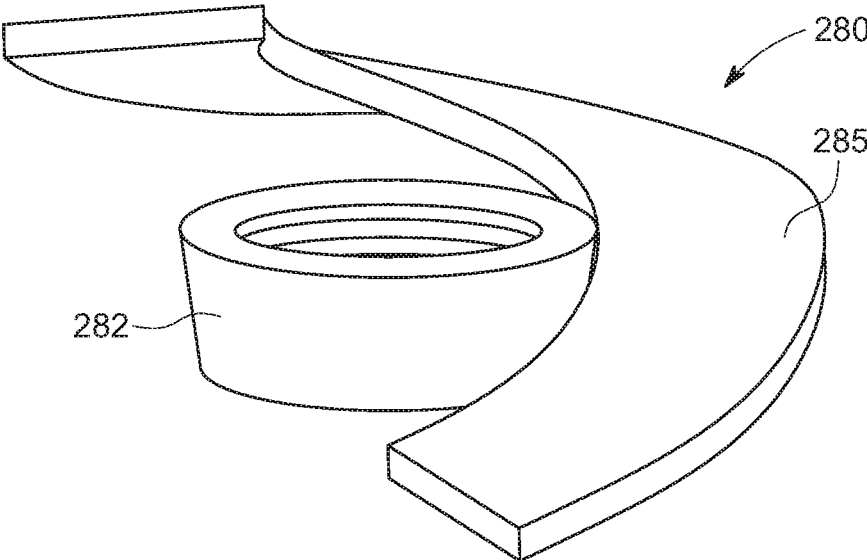

FIG. 14C

THREADED TRUSS FOUNDATIONS AND RELATED SYSTEMS, METHODS AND MACHINES

CROSS-REFERENCE TO RELATED APPLICATIONS

[0001] This is a continuation of U.S. patent application Ser. No. 16/416,022 titled “Thread truss foundations and related systems, methods and machines,” filed May 17, 2019 which claims priority to U.S. provisional patent application No. 62/702,879, filed Jul. 24, 2018, titled “FOUNDATION PIERS FOR AXIAL SOLAR ARRAYS AND RELATED SYSTEMS AND METHODS,” no. 62/718,780, filed Aug. 14, 2018, titled “FOUNDATION PIERS FOR AXIAL SOLAR ARRAYS AND RELATED SYSTEMS AND METHODS,” no. 62/726,909, filed Sep. 4, 2018, titled “FOUNDATION PIERS FOR AXIAL SOLAR ARRAYS AND RELATED SYSTEMS AND METHODS,” no. 62/733,273, filed Sep. 19, 2018, titled “FOUNDATION PIERS FOR AXIAL SOLAR ARRAYS AND RELATED SYSTEMS AND METHODS,” no. 62/748,083, filed Oct. 19, 2018, titled “FOUNDATIONS FOR AXIAL SOLAR ARRAY AND RELATED SYSTEMS AND METHODS,” no. 62/752,197, filed Oct. 29, 2018, titled “SYSTEMS, METHODS AND MACHINES FOR MANUFACTURING A FOUNDATION PILE,” and no. 62/756,028, filed Nov. 5, 2018, titled “CLOSED LOOP FEEDBACK CONTROL FOR IMPROVED SOLAR PILE DRIVING AND RELATED SYSTEMS, MACHINES AND CIRCUITS,” the disclosures of which are hereby incorporated by reference in its entirety.

BACKGROUND

[0002] Utility-scale solar power plants are predominantly configured as fixed-tilt ground mounted arrays or single-axis trackers. Fixed-tilt arrays are arranged in East-West oriented rows of panels tilted South at an angle dictated by the latitude of the array site—the further away from the equator, the steeper the tilt angle. By contrast, single-axis trackers are installed in North-South rows with the solar panels attached to a rotating axis called a torque tube that move the panels from an East-facing orientation to a West-facing orientation throughout the course of each day, following the sun’s progression through the sky. For purposes of this disclosure, both fixed-tilt and single-axis trackers are referred to collectively as axial solar arrays.

[0003] Excluding land acquisitions costs, overall project costs for utility-scale arrays include site preparation (surveying, road building, leveling, grid and water connections etc.), foundations, tracker or fixed-tilt hardware, solar panels, inverters and electrical connections (conduit, wiring, trenching, grid interface, etc.). Many of these costs have come down over the past few years due to ongoing innovation and economies of scale, however, one area that has been largely ignored is foundations. Foundations provide a uniform structural interface that couples the system to the ground.

[0004] When installing a conventional single-axis tracker, after the site has been prepped, plumb monopiles are driven into the ground at regular intervals dictated by the tracker manufacturer and/or the site plan; the tracker system components are subsequently attached to the head of those piles. Most often, the piles have an H-shaped profile, but they may

also be C-shaped or even box-shaped. In conventional, large-scale single-axis tracker arrays, the procurement and construction of the foundations may represent up to 5-10 percent of the total system cost. Despite this relatively small share, any savings in steel and labor associated with foundations will amount to a significant amount of money over a large portfolio of solar projects. Also, tracker development deals are often locked-in a year or more before the installation costs are actually incurred, so any post-deal foundation savings that can be realized will be on top of the profits already factored into calculations that supported the construction of the project.

[0005] One reason monopiles have dominated the market for single-axis tracker foundations is their simplicity. It is relatively easy to drive monopiles into the ground along a straight line with existing technology. Even though their design is inherently wasteful, their relatively low cost and predictable performance makes them an obvious choice over more expensive alternatives. The physics of a monopile mandates that it be oversized because single structural members are not good at resisting bending forces. When used to support a single-axis tracker, the largest forces on the foundation are not from the weight of the components, but rather the combined lateral force of wind striking the solar panels attached to the array. This lateral force gets translated into the monopile foundation as a bending moment. The magnitude of the moment is much greater than the static loading attributable to the weight of the panels and tracker components. Therefore, when used to support single-axis trackers, monopile foundations must be oversized and driven deeply into the ground to stand up to lateral loads.

[0006] There are alternatives to monopiles available in the marketplace but thus far they have not been cost competitive. For example, in very difficult soils where costly refusals dominate, some solar installers will use ground screws instead of H-piles. As the name implies, a ground screw is essentially a scaled-up version of a wood screw or self-taping metal screw, with an elongated, hollow shaft and a tapered end terminating in a blade or point. The screw also has a large, external thread form extending from the tip, up the taper and even partially up the shaft to enable it to engage with soil when screwed into the ground. Such a prior art ground screw is shown, for example, in FIG. 1A. Ground screws like the ground screw 10 in 1A are manufactured and sold by Krinner, GmbH of Strasskirchen, Germany, among others. When installers encounter rocky soils or must install over bedrock, they predrill holes at the location of each ground screw and then drive the screws into the pre-drilled holes, attaching above-ground foundation hardware to the head of each screw.

[0007] When used in foundations for single-axis trackers, ground screws like that in FIG. 1A are typically installed in adjacent pairs. The pairs are joined above-ground with an upside-down T bracket that presents a monopile interface for the single-axis tracker. This is seen, for example, in system 20 in FIG. 1B. Ft. Meyers, Fla. based TERRASMART installs foundations like system 20 using Krinner ground screws. While this may mitigate the problem of refusals, it does not optimize material savings and will only pencil out where less expensive alternatives won’t work. Vertical foundations that support single-axis trackers must resist bending, whether made from H-piles or ground screws. Referring to FIG. 2B, when wind strikes the array, it generates a lateral force labeled F_L in the figure. The magnitude of this force is

equal to F_L multiplied by the height of the pile above the point where the foundation is pinned to the ground (e.g., does not move). This force puts plumb foundation components into bending. Because structural members are generally poor at resisting bending, they must be overbuilt to withstand it.

[0008] Another proposed alternative to percussion driven H-piles and vertical ground screws, uses a pair of ground screws driven at acute angles to each other in an A-frame configuration. Unlike plumb monopiles or the double-screw foundation of FIG. 1B, an A-frame has the advantage of converting lateral loads into axial forces of tension and compression in the legs. This is seen, for example, in published U.S. patent application, 2018/0051915 (herein after, "the '915 application"). FIG. 1C shows the system described in the '915 application. In theory, such a system enables the legs to be thinner than those used, for example, in the system of 1B, because the legs are not subjected to bending. FIG. 2C is a force diagram showing how lateral loads are translated in an A-frame such as that in 1C. Lateral load F_L puts tension on the windward leg and compression on the leeward leg. System 30 is potentially an improvement over plumb piles and parallel ground screws, however, any system that uses standard ground screws is at a costs disadvantage relative to other structures. Moreover, the ground screw's closed geometry mandates a separate pre-drilling step where direct driving is not possible. Therefore, in their current form, and with conventional rotary driving and drilling equipment, it is not possible for ground screws to achieve cost parity with monopile foundations in anywhere other than in the worst soil conditions, and even in those conditions, there is room for significant improvement.

[0009] In recognition of these and other problems, it is an object of various embodiments of this disclosure to provide a truss or A-frame foundation for single-axis trackers and other applications that realizes the benefits of ground screws in a less costly, more robust, and flexible form factor, as well as machines and methods for installing such foundations.

BRIEF DESCRIPTION OF THE DRAWINGS

[0010] FIG. 1A shows a conventional ground screw;
[0011] FIG. 1B shows a conventional double ground screw foundation for single-axis trackers;
[0012] FIG. 1C shows a steeply sloped A-frame foundation for single-axis trackers using a pair of conventional ground screws;
[0013] FIG. 2A is a ground screw supporting a monopile foundation;
[0014] FIG. 2B is a force diagram showing how lateral loads are translated in a monopile foundation;
[0015] FIG. 2C is a force diagram showing how lateral loads are translated in an A-frame foundation;
[0016] FIGS. 3A-D show the manufacturing steps for a tapered ground screw;
[0017] FIG. 4A shows a screw anchor according to various embodiments of the invention;
[0018] FIG. 4B is a close-up view of the threaded end of the screw anchor of FIG. 4A;
[0019] FIG. 4C shows a screw anchor according to various other embodiments of the invention;
[0020] FIG. 5A is a cutaway view of a screw anchor and mandrel during driving according to various embodiments of the invention;

[0021] FIG. 5B shows a screw anchor being driven while a mandrel is simultaneously hammered through the center of the screw anchor;

[0022] FIG. 6A shows a pair of adjacent screw anchors driven into underlying ground to form the base of a truss foundation according to various embodiments of the invention;

[0023] FIG. 6B shows a completed truss foundation supporting a portion of a single-axis tracker according to various embodiments of the invention;

[0024] FIG. 7A shows a refusal of a screw anchor and mandrel while driving due to hitting bedrock according to various embodiments of the invention;

[0025] FIG. 7B shows an intermediate step of a process for in-situ refusal mitigation according to various embodiments of the invention;

[0026] FIG. 7C shows the screw anchor of 7B after in-situ refusal mitigation according to various embodiments of the invention;

[0027] FIG. 7D shows the screw anchor of 7B after an alternative in-situ refusal mitigation technique according to various embodiments of the invention;

[0028] FIG. 8 is a partial cutaway viewing showing an augured drill shaft according to various embodiments of the invention;

[0029] FIGS. 9A-C shows various rock drill bits usable to perform in-situ refusal mitigation according to various embodiments of the invention;

[0030] FIGS. 10A and B are side and front view of a piece of heavy equipment with an attachment for installing screw anchors according to various embodiments of the invention;

[0031] FIG. 11 is a view of a portion of an attachment for driving a screw anchor with a rotary driver and mandrel according to various embodiments of the invention;

[0032] FIG. 12 is an exploded view of an assembly for actuating a mandrel through a rotary driver and screw anchor according to various embodiments of the invention;

[0033] FIG. 13 is a portion of a screw anchor according to various embodiments of the invention; and

[0034] FIG. 14A-C are various views of a helical nut usable with a screw anchor according to various embodiments of the invention.

DETAILED DESCRIPTION

[0035] The following description is intended to convey a thorough understanding of the embodiments described by providing a number of specific embodiments and details involving A-frame foundations used to support single-axis solar trackers. It should be appreciated, however, that the present invention is not limited to these specific embodiments and details, which are exemplary only. It is further understood that one possessing ordinary skill in the art in light of known systems and methods, would appreciate the use of the invention for its intended purpose.

[0036] As discussed in the Background, ground screws are one alternative to conventional monopiles (e.g., H-piles, I-piles, post and cement, etc.). Ground screws are screw into underlying ground with a rotary driving using a combination of downward pressure and torque, much like driving a screw into wood. Usually, they are driven until they are completely or almost completely buried and then other hardware such as mounting brackets, braces, or supports may be attached to

the portion remaining above-ground to support signs, decks, small building frames, and single-axis solar trackers among other structures.

[0037] Like any screw, the ground screw's pointed tip serves at least two functions: one, it allows the screw to be precisely oriented over the insertion point and provides a lead-in to help keep it on path and to pull the screw into the ground when driving. Second, the point and taper increase pressure around the threads as the screw penetrates, helping them to better grip the soil. The tip may also displace small rocks that could impede driving. All these benefits, however, are realized during driving. After the screw is in the ground, the tip serves little purpose and may be less effective than the remainder of the screw at resisting axial forces due to its tapered geometry. One reason why ground screws are seldom used in large-scale single-axis trackers is that they are relatively difficult and expensive to manufacture compared to H-piles and therefore cost more. A process for making a ground screw is shown, for example, in FIGS. 3A-D.

[0038] The process starts with cutting a length of rounded hollow pipe to a desired length. Then, one end of the pipe is inserted in an oven or electric heater and until it reaches a supercritical temperature. The hot end is then inserted into a shrinking machine that closes the tip imparts a taper and point. Once that cools, a strip of metal is formed around the pipe in a thread pattern and is welded to the pipe's surface. After it cools, the finished screw is galvanized to complete the manufacturing process. The two hot-forming steps require a large amount of input energy and the welded thread form is much more expensive than equivalent structure formed in a cold process. Also, the intermediate hot steps preclude the use of metal that has been pre-galvanized. Post manufacturing galvanization is much more expensive than starting with pre-galvanized metal.

[0039] To a large extent, the way that ground screws are installed and used requires that this expensive, multi-step manufacturing process. Screws need a tip to assist with driving and monopiles must be overbuilt to withstand bending forces that are orthogonal to the axis of the screw. The system shown in the '915 application overcomes the latter problem by translating the lateral load into axial forces of tension and compression, however, the magnitude of the tensile and compressive forces increases exponentially the steeper the legs are angled (e.g., the smaller the apex angle between the truss legs)—a fact not recognized in that '915 application. Therefore, even though the foundation shown in 1C may avoid bending, the large axial forces generated by the steep angles recommended will still require the ground screws to be overbuilt relative to A-frames oriented as less steep legs or with a larger apex angle. Moreover, because the system is built on ground screws, it still suffers from the inherent cost disadvantages discussed herein.

[0040] The inventors of this invention have proposed a foundation system, particularly well-suited for axial solar arrays (e.g., single axis trackers and fixed-tilt ground mounted arrays), that uses a pair of adjacent angled supports configured as a moderately angled A-frame (below 72.5 degrees) instead of a single vertical pile. The system is known commercially as EARTH TRUSS. FIG. 4A shows the base EARTH TRUSS component, screw anchor 200. Screw anchor 200 consists a section of elongated pipe having a substantially uniform diameter along its length that is open at both ends. These are important distinctions over

conventional ground screws. The bottom or below-ground end of screw anchor 200 has an external thread form beginning proximate the lower end that increases in diameter as it extends up the pipe until it levels out to a uniform diameter for several more rotations. This is seen in greater detail in 4B, which shows only threaded portion 210 of anchor 200. As is discussed in greater detail herein, the significance of the tapered lead in may come in during driving as well as when doing in-situ refusal mitigation. The other end of exemplary anchor 200 in 4A has a connection portion 220, which in this example, is shown as a coupling. Connecting portion 220 has features that engage with the chuck of a rotary driver to enable screw anchor 200 to be driven. Connecting portion 220 also has at least one coupling feature to enable screw anchor 200 to be connected to other components that extend along substantially the same axis to make a two-piece leg.

[0041] It should be appreciated that in various embodiments, riving features may instead be stamped into the upper end of screw anchor 200 rather than part of a separate attached element. Moreover, a combination of camming and friction or other suitable mechanical technique may enable screw anchor 200 to be rotated into the ground without any driving features built into the upper end. In such embodiments, a separate connecting portion may be used or coupling elements may be built into other components above screw anchor 200.

[0042] FIG. 4C shows screw anchor 250 according to various other embodiment of the invention. Screw anchor 250 differs from screw anchor 200 in that the it has a slight taper to the tip rather than having a tapered lead in on the external thread form. Although this may be more expensive to manufacture than screw anchor 200, as long as the opening at the tapered end is sufficiently large, it may enjoy all of the other benefits of anchor 200 as discussed herein. Other embodiments may utilize both a slightly tapered tip and thread form with a tapered lead-in.

[0043] In various embodiments, a screw anchor such anchor 200 or anchor 250 will be rotated into the ground using a rotary driver or other like device. The rotary driver may rotate the screw anchor from the top or may be partially or fully inserted into the pile to rotate it partially from within. Because the various screw anchors disclosed herein are open at both ends, and as discussed in greater detail herein, it is possible, and may be desirable to insert another tool into the shaft of the pile from above during driving to clear a path ahead of the pile, to increase soil pressure around the thread form, and even to excavate a cavity in solid rock to receive the pile.

[0044] Turning to FIGS. 5A and B, various embodiments of the invention take advantage of the open geometry of the screw anchor to insert tools into it during driving. In various embodiments, these tools may provide some of the benefits of a tip on a conventional ground screw and yet due to the hollow body, do not need to remain in the ground after the screw anchor is installed. To that end, FIG. 5A is a partial cutaway view showing a portion of exemplary screw anchor 200 with mandrel 300 extending through its center. Mandrel 300 is an elongated member, preferably of high strength steel and with a smaller outside diameter than the inside diameter of screw anchor 200. In various embodiments, mandrel 300 may have a detachable tip 310 that is profiled for the specific soil conditions present and to facilitate tip replacement without discarding the entire mandrel. Mandrel

300 may be actuated to apply downward pressure as screw anchor **200** is simultaneously rotated around it. Alternatively, mandrel **300** may apply a hammering force.

[0045] In various embodiments, the open geometry of screw anchor **200** makes it possible for tools such as a mandrel to be independently operated within anchor **200** and to be removed after driving is complete, leaving only those component required to resist axial forces in the ground. As seen in FIGS. **5A** and **B**, during installation mandrel **300** may be inserted into the top end of screw anchor **200**, slid all the way down its length until it reaches the opposing, below-ground end and actuated to push or hammer against the underlying ground. In various embodiments, and as discussed in greater detail herein, mandrel **300** may be connected to a separate driver that is aligned on an axis overlapping with an axis through the center of mass of screw anchor **200**. Mandrel **300** may travel with screw anchor **200** as it is rotated in to prevent soil from plugging into the center of screw anchor **200**. Alternatively, mandrel **300** may push downward ahead of the screw anchor to help clear a path and create soil tension around external thread form **210**. This may be true whether the mandrel exerts steady downward pressure, is reciprocated, or is hammered into the underlying soil.

[0046] Reciprocating, hammering or simply pushing down with the mandrel may also allow it to displace and/or break up smaller rocks that are in the driving path. Without such action, rocks and other obstructions may cause a refusal and/or damage screw anchor **200**. In the field of solar pile driving, a refusal occurs when additional driving force fails to result in further embedment. Usually, this indicates that the pile has struck a rock, cementitious soil or, in the extreme case, solid bedrock. By reciprocating, hammering or pushing down with the mandrel, it functions as a chisel that can crumble small rocks, buried objects and pockets of dense or cementitious soil. This is shown and discussed in greater detail, in the context of FIGS. **7A-D**.

[0047] Turning to FIGS. **6A** and **B**, these figures show two stages of installation of a pair of adjacent screw anchors and a truss foundation for a single-axis tracker using such screw anchors according to various exemplary embodiments of the invention. In **6A**, screw anchors **200** have been driven into the ground adjacent one another and inclined inward at acute angles (e.g., less than 90-degrees). In various embodiments, and as shown here, they may be driven until almost entirely embedded, so that only the end portion remains above ground. As shown in FIGS. **5A** and **B**, anchors **200** may be driven through the unique process described herein whereby screw anchor **200** is rotated into the underlying soil at the desired angle with a combination of torque and downward pressure by a rotary driver, while, at the same, time, a mandrel or other tool is actuated through the screw anchor to assist driving. Once both screw anchors **200** reach their respective target depths, above-ground components are attached.

[0048] In the example of **6A** and **B**, upper legs **225** are inserted over connecting portions **220** to substantially extend the main axis of each screw anchor **200** toward the bearing housing. Free ends of each upper leg **225** are joined together to form a unitary A-framed-shaped truss by adapter **230**. In various embodiments, and as shown here, adapter **230** may have a pair of symmetric connecting portions that extend down and away from the adapter to match the spacing and angle of upper legs **225**. A bearing assembly, such as

assembly **240** is attached to the top of adapter **230** and torque tube **245** rotatably captured within bearing **242**.

[0049] Turning now to FIGS. **7A-D**, these figures show various driving scenarios with a screw anchor and system for driving a screw anchor according to various exemplary embodiments of the invention. Starting with **7A**, in this figure screw anchor **200** is driven into the supporting soil underlying the anchor. In various embodiments, and as discussed and shown herein, this is accomplished with a rotary driver or screw driving machine. At substantially the same time, mandrel **300** is actuated through screw anchor **200** to press down, hammer and/or reciprocate against the soil as anchor **200** travels along its path. In various embodiments, and as shown in the figure, mandrel tip **310** may project out of the below-ground end of screw anchor **200** as it is driven. In some embodiments, it may stay at substantially the same position relative to the lower end of anchor **200**, traveling down with anchor **200** to displace soil and increase soil pressure around the anchor's threads. In other embodiments, mandrel tip **310** may exert downward pressure independent of the pile. If the rotary driver encounters excessive driving resistance as indicated, for example, by a reduction or stoppage in downward travel or excessive resistance against the rotary driver or both, mandrel **300** may be partially retracted so that tip **310** no longer projects out of the anchor to allow dirt to plug in the end, thereby relieving the soil pressure retarding driving. This reduction in pressure may reduce resistance to the rotary driver. It is important when screwing a pile or ground screw into the ground that the pile continues moving forward so that it doesn't auger or core the hole, which will reduce the pile's resistance to axial forces.

[0050] At some point while driving, mandrel tip **310** in **7A** encounters solid bedrock resulting in a refusal. In various embodiments, a unique in-situ refusal mitigation process begins that was previously impossible in the prior art with conventional ground screw or with H-piles. The refusal condition may in various embodiments be detected by an operator or by an automated feedback loop sensing the failure of the mandrel or anchor to penetrate any further. In various embodiments, the operator will remove the mandrel from anchor **200** and replace it with a rock drill such as drill **400**. In some embodiments, the rock drill may be a different attachment to the same driver actuating the mandrel. In other embodiments, the rock drill may be a different machine, requiring the mandrel driver to be pivoted or otherwise moved out of the way to make room for the rock drill. Once out, mandrel **300** is replaced with a drill shaft **400** and rock drill bit **410**. These components are inserted into the top end of anchor **200** and passed through it until reaching the bedrock below. In various embodiment, the same driver used to actuate the mandrel is used to actuate the rock drill. The rock drill may consist of a down-the-hole hammer and bit that uses compressed air to hammer the bit inside of anchor **200**. Alternatively, the rock drill may be a top hammer whereby hammering action is applied to shaft **400** and this force is directly translated to rock bit **410**.

[0051] As is known in the art, rock drills typically use pressurized air to generate the hammering action and to blow the crushed rock spoils out of the way. The specific action of the rock drill (e.g., hammering, rotating) will in part be dictated by the type of drill bit used. For example, a button bit typically employs hammering action alone

whereas other types of bits may rely on a combination of hammering and rotary cutting.

[0052] In various embodiments the rock drill will continue its action until a cavity has been formed in the rock having the desired depth. This depth may be the minimum depth required to secure the screw anchor or the original target depth. In either case, once the cavity is created, the rock drill is removed, or least partially withdrawn from anchor **200** so as not to project below it and the rotary driver is engaged to drive the anchor into the newly formed cavity. In various embodiments, the tapered lead-in on the threads will increase the likelihood that the application of torque and downward pressure on anchor **200** will guide it into the cavity. In some embodiments, screw anchor **200** may be driven all the way to the bottom of the cavity, such as shown in **7C**. This will depend on the size of the bore relative to the outside diameter of the anchor, how clean and free of spoils the cavity is, and the geometry and dimensions of the thread form. In other embodiments, anchor **200** may not be able to be fully driven to the bottom of the cavity. This may be a consequence of the blind underground conditions (e.g., cleanliness of the borehole, density of soil above the borehole) or the dimensions of drill bit **410** or threads. In either case, it may only be possible to drive a portion of anchor **200** into the cavity. In some cases, driving anchor **200** as deeply as possible may provide sufficient engagement between the anchor threads and the wall of the cavity without additional steps. This could, in various embodiments, be confirmed by pulling up on anchor **200** with the rotary driver or another tool with a fixed force. In other cases, if sufficient engagement between the threads and the wall of the cavity is not achieved, additional steps may be required.

[0053] To that end, drill shaft **400** and bit **410** may be withdrawn from driven anchor **200** and a coupler or other device such as coupler **430** may be dropped down anchor **200** until it reaches the bottom of the cavity. In various embodiments, coupler **430** may be a piece of rebar or other rigid material that is small enough to fit within anchor **200** but long enough to extend from the bottom of the cavity into anchor **200**. The purpose of coupler **430** is to connect anchor **200** to the underlying rock. One or more centralizers **435** or other like devices may be used to maintain coupler **430**'s orientation within the center of anchor **200** as well as in the cavity. After coupler **430** is placed, a volume of pressurized grout, epoxy or other suitable material **440** may be injected via the above-ground end of anchor **200**, filling the cavity completely and surrounding coupler **430** and the portion of anchor **200** containing the coupler. Once material **440** sets, anchor **200** will be firmly coupled to the bedrock.

[0054] FIG. **8** shows an augered drill shaft usable with various embodiments of the invention. Depending on the type of bit used and whether a top hammer or bottom hammer is used, it may be necessary and/or desirable to use mechanical energy to remove spoils generated by the drill from the shaft of anchor **200**. To that end, drill shaft **402** includes a series of helical threads circumscribing some, most or all of its length. These threads will tend to move material up and out of the inside of anchor **200** when the shaft is rotated in the correct direction (clockwise in the exemplary shaft **402** shown in the Figure). Also shown is male threaded portion **405** at the base of shaft **402** for attaching different drill bits. It should be appreciated that threaded portion **405** is exemplary only and meant merely to signify that tips may be removed from shaft **405** without

needing to discard the entire shaft. In other embodiments, a female opening, a pin connection, conical threads, or other known fastening mechanisms or their functional equivalents may be used instead.

[0055] Turning now to FIGS. **9A-C**, these figures show several different drill bits that may be used with various embodiments of the invention. The first bit, bit **410A** is a cross bit or cross rock bit. It consists of four raised chisel-type blades oriented in a cross pattern. This type of bit is typically made of steel with the blades coated with titanium or made from hardened steel or carbide. The bit may be hammered and rotated to chisel and scrape through rock while the spoils are evacuated via the space between the four blades. FIG. **9B** shows tri-cone roller bit **410B**. The tri-cone roller bit has three rotating cone-shaped wheels covered in steel or carbide cutting teeth that are attached to a stationary head via a bearing connection. As the drill is rotated, these cones roll along the bottom of the bore hole in a circular pattern chipping away at the underlying rock. Downward pressure on the bit facilitates the cutting. Such bits are commonly used in water, gas and oil exploration and extraction. Spoils are drawn up an annulus in the center of the bit with compressed air or fluid. The last bit shown in **9C** is percussion-type hammer bit **410C**. Hammer bits are not sharp and do not use cutting as their primary boring mechanism. Rather, a series of hardened carbide buttons are embedded in the face of the bit. During rotation, a shank beats against an anvil or strike surface inside the bit head causing the buttons to pulverize any rock they come into contact with while rotation and compressed air sweeps the debris out of the way and into debris channels so that the next impact will again strike virgin rock. Any of the bits shown in FIGS. **9A-C**, or any other commercially available or as of yet undeveloped bits may be used with the various embodiments of the invention.

[0056] In certain situations where drilling is required, it may be desirable to drill a cavity that has a slightly larger outside diameter than the base pile. For example, to create a cavity that is wide enough to at least partially accept the threaded end **210** of screw anchor **200**. To that end, bit **410C** in FIG. **9C** is one type of bit capable of drilling a larger diameter hole than the casing it is inserted in. This technique is often employed in drill-and-case applications where the diameter of the bore needs to be larger than the diameter of the casing to allow spoils to be ejected around the outer diameter of the pipe among other reasons. Bit **410C** accomplishes this with one or more deployable wings, labeled "W" in the figure, that expand the cutting diameter of the bit once the bit is free of the anchor. When bit **410C** is initially inserted into the end screw anchor **200**, the one or more wings are recessed to be flush with the outside surface of the bit. This can be done mechanically or by an operator compressing them as the bit is inserted into the anchor. When the bit emerges from the other end, and the wings are no longer compressed by the inner surface of the anchor, so they expand to their relaxed position, either under spring action or via another deployment mechanism, thereby increasing the cutting diameter of the bit. In various embodiments, additional carbide buttons may be formed on the cutting surface of the wings (e.g., the surface that is normal to the direction of drilling). In various embodiments, if the wings are spring loaded, the resistance from the rock will tend to keep them out, that is, at the expanded orientation. Once the desired depth has been achieved and the bit and

shaft are drawn back into the bottom end of the anchor, pressure against the back of the one or more wings from the anchor opening will push them back to the recessed position, reducing the outside diameter of the bit, allowing it to be drawn up and out of the anchor. It should be appreciated that there are various other bits available for undercut drilling, including ones that are intentionally offset so that once they begin to rotate they sweep around a larger diameter circle.

[0057] Contrary to the cementitious and/or rocky soils that lead to refusals, some soils may be so loosely structured that they provide very little resistance to driving, but at the same time, lack the ability to resist axial forces of tension and compressions. In such soils, threaded screw anchor 200 alone may need more orthogonal surface area to provide the required resistance. To that end, FIGS. 14A-C show a helical nut according to various embodiments of the invention that may be usable with a screw anchor such as screw anchor 200 in FIG. 13 to increase the anchors ability to resist axial forces in such soils. Starting with 14A and B, these figures show helical nut 270 according to various exemplary embodiments. As shown, helical nut 270 consists of main body portion 272 and helix 274. As seen in the cutaway view of 14B, the inside of main body portion 272 is threaded. In various embodiments, the depth and pitch of these threads will match the pitch and depth of external threads 210 on anchor 200. This will enable helical nut 270 to be spun onto anchor 200 until the tapered lead-in of the thread form projects further than the female thread depth in helical nut 270. When anchor 200 is driven into underlying ground with helical nut 270 attached, clockwise rotation of the anchor will reinforce rather than loosen the connection between nut 270 and threaded portion 210. The outside diameter of helix 274 can substantially increase the amount of orthogonal surface area, creating a column or cone of resistance to pull-out and making it very difficult to further compress anchor 200 after it's driven.

[0058] FIG. 14C shows another embodiment of a helical nut usable with a screw anchor according to various exemplary embodiments of the invention. Nut 280 of 14C consist of threaded retaining nut 282 and separate helix 280. In various embodiments, helix 280 has a pitch that matches the pitch of the threads on threaded portion 210 and a center opening slightly larger than the outside diameter of anchor 200 so that helix 280 can be threaded up anchor 200 to a desired location. Then, threaded retaining nut 282, which preferably has threads substantially matching those of helical nut 272, that is, threads that are the same pitch and depth of threaded portion 210 so that retaining nut 282 can also be threaded onto threaded portion 210 to press helix 285 against the external threads at the desired location and to capture it there. Driving the resulting helical screw anchor may be performed in the same manner as described herein.

[0059] Up to this point, the disclosure has focused on screw anchors and techniques for driving the screw anchor. The remainder of this disclosure will focus on exemplary machines and methods of operating machines to drive screw anchors into supporting ground while actuating a mandrel or rock drill through the screw anchor according to various embodiments of the invention. It should be appreciated that machines shown in these figures are exemplary only and should be considered in terms of their functionality with respect to driving screw anchors rather than their physical attributes as shown in the drawings. Different physical

embodiments are possible while retaining the spirit and scope of the various embodiments of the invention.

[0060] Turning to FIGS. 10A and 1B, these figures show side and front views respectively of exemplary machine 600 for driving screw anchors according to various embodiments of the invention. As shown, machine 600 includes a main body 605 riding on a tracked chassis 610. It should be appreciated that machine 600 could instead have tires, a combination of tires and tracks, one or more floating pontoons, rails or other known means. As shown, machine 600 has an attachment, attachment 500, mounted to the end of articulating arm 620. In various embodiments, articulating arm 620 is part of the base machine and can move through an arc of approximately 90 degrees from a stowed position where the arm is substantially perpendicular to the ground to an in-use position where the arm is substantially parallel to the ground. In various embodiments, the end of articulating arm 620 is also able to rotate through a range of angles about its axis (e.g., ± 35 -degrees from vertical) so that screw anchors may be driven into the ground at non-plumb angles. This also decouples the screw anchor driving axis from the orientation of the machine by allowing it to compensate for uneven terrain in at least the East-West direction. Alternatively, a rotator may be located at the end of arm 620 so that the entire arm does not have to rotate in order to rotate attachment 500. In various embodiments, the end of articulating arm 620 supports driving attachment 500 with a main axis that may be substantially perpendicular to articulating arm 620. Therefore, when arm 620 is in the stowed position, attachment 500 will be substantially parallel to the ground, minimizing its height, whereas when arm 620 is in the in-use position, driving attachment 500 will be substantially perpendicular to the ground.

[0061] As shown in the example of FIGS. 10A/10B, attachment 500 includes frame 510 that functions as a scaffold to support rotary or screw driver 550 and mandrel driver 520, and that provides a common axis for them to move along. In various embodiments, frame 510 includes a pair of parallel side members 510A/B that are interconnected by cross members. This configuration is exemplary only. Various trussed and/or reinforced supports, beams and cross members may be used to provide the requisite rigidity and strength. Frame 510 may also include one or more tracks that the mandrel driver and rotary driver travel on to limit their movement to axial movement only. The one or more tracks may be located between parallel side member 510A/B, or, alternatively, as shown in the figures, may be attached to the side members 510A/B. In still further alternatives, mandrel driver 520 and rotary driver 550 may travel on wheels inside recesses formed in parallel side members 510A/B. The specific mechanism used to limit movement to a single axis along attachment 500 is a design choice.

[0062] In various embodiments, one or more linked drive chains and corresponding motor assemblies may be used to move mandrel driver 520 and rotary driver 550 along the one or more tracks. In various embodiments, they may move independent of one another. In other embodiments, they may move together. In still further embodiments, both modes may be possible. For example, when driving, rotary driver 550 will apply torque while a motor driving chain 515 will generate downforce that is translated to the anchor via rotary driver 550. Therefore, from the perspective of the screw anchor the rotary driver is applying torque and axial force even the source of the axial force may be a motor driving the

chain. Similarly, mandrel driver **520** may applying a hammering action to mandrel **300** however, axial downforce may also come from the motor driving chain **515**, which in turn, pull mandrel driver **520** downwards. This force, however, is translated through the mandrel driver to the mandrel so from the perspective of the mandrel both of these axial forces (hammering and downward pressure) are coming from the mandrel driver.

[0063] In various embodiments, rotary driver **550** may be powered by electric current or by hydraulic actuation in a manner known in the art. Similarly, mandrel driver **520** may be powered by compressed air, electric current or by hydraulic actuation. Mandrel driver **520** may be a hydraulic drifter or other suitable device for generating downforce and/or hammering force. In various embodiments, and as shown in the figures, mandrel driver **520** and rotary driver **550** may be oriented concentrically on the frame in the direction of the one or more tracks so that the shaft of mandrel **300** can pass through rotary driver **550** and move up and down within driver **550** while it is rotating a screw anchor into the ground. In this manner, tip **310** of mandrel **300** may operate ahead of screw anchor **200**, projecting out of its bottom (below-ground) opening, to clear a path for and ahead of screw anchor **200**. This may also allow mandrel **300** to be dropped down through rotary driver once it is decoupled from driver **520** for repair and/or replacement without completely disassembling attachment **500**.

[0064] With continued reference to FIGS. **10A** and **10B**, exemplary machine **600** has a main body portion **605** housing the machine's petrol engine or electric motor, a fuel tank or power cell, a hydraulic system, counterweights if necessary, and a control interface, sitting on tracked chassis **610**. Machine **600** may also have an air compressor and air lines for supplying pressurized air to an air hammer or other equipment, a power take-off for mechanically transferring power to external devices, an electrical connection for providing electric power to attachment **500**, and one or more hydraulic interfaces for communicating hydraulic fluid to attachment **500**, mandrel driver **520**, and/or rotary driver **550**. In the example of FIGS. **10A/B**, articulating arm **620** projects away from one end of the machine (e.g., front or rear), functioning as an attachment support. In other embodiments, it may project from either side. In still further embodiments, arm **620** may be mounted on a rotatable turret that can rotate completely around a vertical axis over tracked chassis **610** to any radial orientation. Dotted lines in FIG. **10B** on either side of attachment **500** show how it can rotate about a rotation point to drive screw anchors into the ground at angles.

[0065] FIG. **11** is a close-up view of mandrel driver **520** and rotary driver **550**. For ease of illustration, the attachment and machine have been intentionally omitted. In the exemplary configuration shown here, mandrel **300** is attached to mandrel driver **520** via pin connection **521**. As noted herein, in various embodiments, this may enable simplified removal of the mandrel **300** by removing the pin and allowing mandrel **300** to drop through rotary driver **550** under the force of gravity. In various embodiments, one or more bearings such as bearing **552** are located above and below rotary driver **550** to limit the motion of the mandrel **300** and prevent it from damaging rotary driver **550**. Rotary driver **550** may have a rotating head such as head **555**, chuck, or other device for transferring torque and downward pressure to screw anchor **200**. The partial cutaway at the bottom of

FIG. **11** shows that the fitment of mandrel **300** within screw anchor **200**. In this exemplary figure, movement of rotary driver **550** and mandrel driver **520** are facilitated via a chain and drive motor moving the chain. In various embodiments, rotary driver **550** is fixed to chain **515**, while mandrel driver **520** is attached but able to be decoupled from chain **515** for independent movement or to stay in place. It should be appreciated that instead of a chain two or more hydraulic actuators may be used to push and pull rotary driver **550** along its axis of travel and to make mandrel driver **520** travel with it or independent of it. The specific manner in which downforce is generated and the way that rotary driver **550** and mandrel driver **520** travel along their axis is a design choice.

[0066] As discussed herein, the ability to actuate tools through the screw anchor while driving is a major advantage relative to conventional ground screws. This is possible because both ends of the screw anchor are open. Having the ends open is accomplished with fewer rather than more manufacturing steps, allowing a less expensive and energy intensive manufacturing process. The tools can mimic the functionality and benefits of the ground screw tip, all of which are realized during driving, while providing better pull out and compressive resistance per unit of length because the tip is removed after driving. To accomplish this, depending on how torque is imparted to the screw anchor, it may be necessary for the mandrel to pass directly through the rotary driver. FIG. **12** shows one assembly for accomplishing this, however, it should be appreciated that there are many possible ways of doing so.

[0067] FIG. **12** is a partial exploded view of a drive train and gear assembly stack that allows mandrel **300** to actuate within rotary driver **550** without affecting its operation according to various embodiments of the invention. As shown, at its top end, output gear **551** is mechanically coupled to the output shaft of an electric or hydraulic motor. It may be directly coupled to the output or coupled via a transmission or other reduction gear assembly (not shown) to provide greater mechanical advantage. Output gear **551** is synchronized to two-part drive gear **552** consisting of driven portion **553** and driving portion **554**. In various embodiments, driving portion **554** is splined to interface with splines in sun gear **576** that is the center of planetary gear assembly **575**. Planetary gear assembly **575** consists of ring gear **571** on the inside of housing **570** that retains planetary gears **577** orbiting sun gear **576**. As drive gear **551** rotates driven portion **553** of the drive gear, driving portion **554** rotates sun gear **576** in place. Sun gear **576** drives planetary gears **577**, in this case, four planetary gears, to rotate within ring gear **571**. Planetary carrier **580** is attached to the center of each planetary gear **577** with a bearing to generate output power for the rotary driver. Planetary carrier **580** includes splined hub **581** that mates with splined driving head **582**. A chuck or drive plate such as drive plate **554** in FIG. **11** or driving chuck **555** in FIG. **12** is connected to splined driving head **582** to transfer torque to the head of a screw anchor. Though now shown, one or more bearing collars may be positioned at the point where mandrel **300** enters and exists housing **570** of rotary driver **550** to limit its motion to the axial motion without affecting the rotary driver's motion.

[0068] The embodiments of the present inventions are not to be limited in scope by the specific embodiments described herein. Indeed, various modifications of the embodiments of the present inventions, in addition to those described herein,

will be apparent to those of ordinary skill in the art from the foregoing description and accompanying drawings. Thus, such modifications are intended to fall within the scope of the following appended claims. Further, although some of the embodiments of the present invention have been described herein in the context of a particular implementation in a particular environment for a particular purpose, those of ordinary skill in the art will recognize that its usefulness is not limited thereto and that the embodiments of the present inventions can be beneficially implemented in any number of environments for any number of purposes. Accordingly, the claims set forth below should be construed in view of the full breath and spirit of the embodiments of the present inventions as disclosed herein.

1. A screw anchor formed by the steps of:
 - forming a hollow, open-ended tube of steel having a substantially uniform inside diameter;
 - attaching an external thread form beginning at a first end of the tube and terminating at a point along the tube's length; and
 - attaching a driving coupler at a second, opposing, end of the tube, wherein the external thread form has a tapered lead-in.
2. The screw anchor formed by the steps of claim 1, further comprising the step of applying an anti-corrosion coating to the screw anchor.
3. The screw anchor formed by the steps of claim 2, wherein the anti-corrosion coating is a galvanizing coating.

4. A method of forming a screw anchor comprising:
 - forming an elongated section of tubular steel having open ends and a substantially uniform inside diameter;
 - attaching a driving coupler to a first end of the elongated section; and
 - attaching an external thread form to the elongated section of tubular steel, beginning at a first end and terminating at a point along the section, wherein the external thread form has a tapered lead-in.
5. The method according to claim 4, further comprising dipping the formed screw anchor in an anti-corrosion solution.
6. The method according to claim 5, wherein the anti-corrosion solution is a galvanizing solution.
7. A process for forming a component for a solar foundation comprising the steps of:
 - forming an elongated section of metal tube, the elongated section having a substantially uniform inside diameter and remaining open at opposing ends;
 - forming a driving feature at one end of the elongated section;
 - beginning at an opposing end of the elongated section, forming an external thread form that terminates at a point along the elongated section; and
 - imparting a tapered lead-in to the external thread form.
8. The process according to claim 7, further comprising the step of submerging the formed foundation component in a corrosion inhibiting solution.
9. The process according to claim 8, wherein the corrosion inhibiting solution is a galvanizing solution.

* * * * *