



(19) **United States**

(12) **Patent Application Publication**

Fung

(10) **Pub. No.: US 2020/0261767 A1**

(43) **Pub. Date: Aug. 20, 2020**

(54) **SYSTEM AND METHOD FOR RANGE OF MOTION ANALYSIS AND BALANCE TRAINING WHILE EXERCISING**

which is a continuation-in-part of application No. 15/853,746, filed on Dec. 23, 2017, now Pat. No. 10,265,578,

(Continued)

(71) Applicant: **BLUE GOJI LLC.**, Austin, TX (US)

(72) Inventor: **Coleman Fung**, Spicewood, TX (US)

(21) Appl. No.: **16/867,238**

(22) Filed: **May 5, 2020**

Related U.S. Application Data

(63) Continuation-in-part of application No. 16/793,915, filed on Feb. 18, 2020, which is a continuation-in-part of application No. 16/255,641, filed on Jan. 23, 2019, now Pat. No. 10,561,900, which is a continuation of application No. 16/223,034, filed on Jan. 23, 2019, now Pat. No. 10,688,341, which is a continuation-in-part of application No. 16/176,511, filed on Oct. 31, 2018, which is a continuation-in-part of application No. 16/011,394, filed on Jun. 18, 2018, now Pat. No. 10,155,133, which is a continuation-in-part of application No. 15/853,746, filed on Dec. 23, 2017, now Pat. No. 10,265,578, which is a continuation of application No. 15/219,115, filed on Jul. 25, 2016, now Pat. No. 9,849,333, which is a continuation-in-part of application No. 15/193,112, filed on Jun. 27, 2016, now abandoned, which is a continuation-in-part of application No. 15/187,787, filed on Jun. 21, 2016, now Pat. No. 10,124,255, which is a continuation-in-part of application No. 15/175,043, filed on Jun. 7, 2016, now Pat. No. 9,766,696, Continuation-in-part of application No. 16/793,915, filed on Feb. 18, 2020, which is a continuation-in-part of application No. 16/255,641, filed on Jan. 23, 2019, now Pat. No. 10,561,900, which is a continuation of application No. 16/223,034, filed on Jan. 23, 2019, now Pat. No. 10,688,341, which is a continuation-in-part of application No. 16/176,511, filed on Oct. 31, 2018, which is a continuation-in-part of application No. 16/011,394, filed on Jun. 18, 2018, now Pat. No. 10,155,133,

Publication Classification

- (51) **Int. Cl.**
 - A63B 24/00* (2006.01)
 - A63B 22/02* (2006.01)
 - G06F 1/16* (2006.01)
 - G06T 19/00* (2006.01)
 - A63B 23/04* (2006.01)
 - A63B 22/00* (2006.01)
 - A63F 13/65* (2006.01)
 - G06F 3/01* (2006.01)
 - A63F 13/40* (2006.01)
 - A63B 22/06* (2006.01)
 - A63F 13/214* (2006.01)
 - A63F 13/212* (2006.01)
- (52) **U.S. Cl.**
 - CPC *A63B 24/0003* (2013.01); *G06F 3/0304* (2013.01); *G06F 1/163* (2013.01); *G06T 19/006* (2013.01); *A63B 23/04* (2013.01); *A63B 22/0046* (2013.01); *A63B 22/0292* (2015.10); *A63F 13/65* (2014.09); *G06F 3/016* (2013.01); *A63F 13/40* (2014.09); *A63B 22/06* (2013.01); *G06F 3/011* (2013.01); *A63F 13/214* (2014.09); *A63F 13/212* (2014.09); *A63B 22/0285* (2013.01)

(57) **ABSTRACT**

A system and method for range of motion analysis while exercising, including methods for constructing user movement profiles based on repeated and typical user movements during exercises as are typical for an adult of a user's age, weight, etc., and capable of warning a user of unhealthy, unsafe, or anomalous movement patterns during exercise, using a balance trainer, range of motion analyzer, and a plurality of sensors in conjunction with an exercise device, in an effort to reduce health risks to users during exercise with an enhanced or mixed reality exercise device.

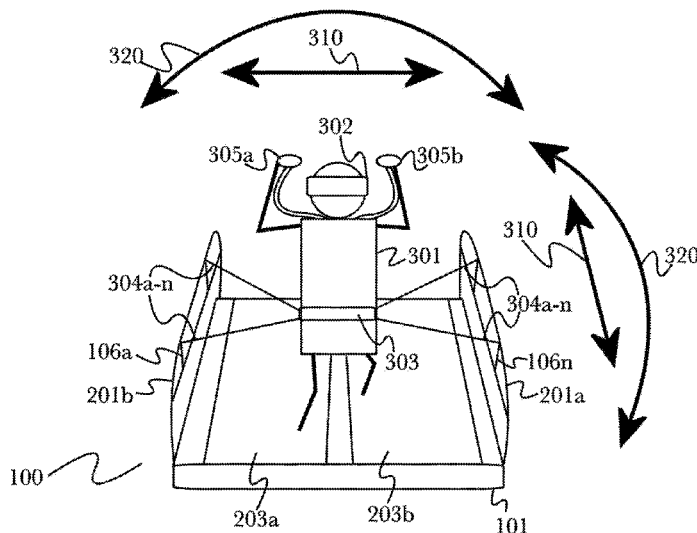

Related U.S. Application Data

- which is a continuation of application No. 15/219,115, filed on Jul. 25, 2016, now Pat. No. 9,849,333, which is a continuation-in-part of application No. 15/193,112, filed on Jun. 27, 2016, now abandoned, which is a continuation-in-part of application No. 15/187,787, filed on Jun. 21, 2016, now Pat. No. 10,124,255, which is a continuation-in-part of application No. 14/846,966, filed on Sep. 7, 2015, now Pat. No. 10,080,958, which is a continuation-in-part of application No. 14/012,879, filed on Aug. 28, 2013.
- (60) Provisional application No. 62/697,973, filed on Jul. 13, 2018, provisional application No. 62/330,642, filed on May 2, 2016, provisional application No. 62/330,602, filed on May 2, 2016, provisional application No. 62/310,568, filed on Mar. 18, 2016, provisional application No. 61/696,068, filed on Aug. 31, 2012.

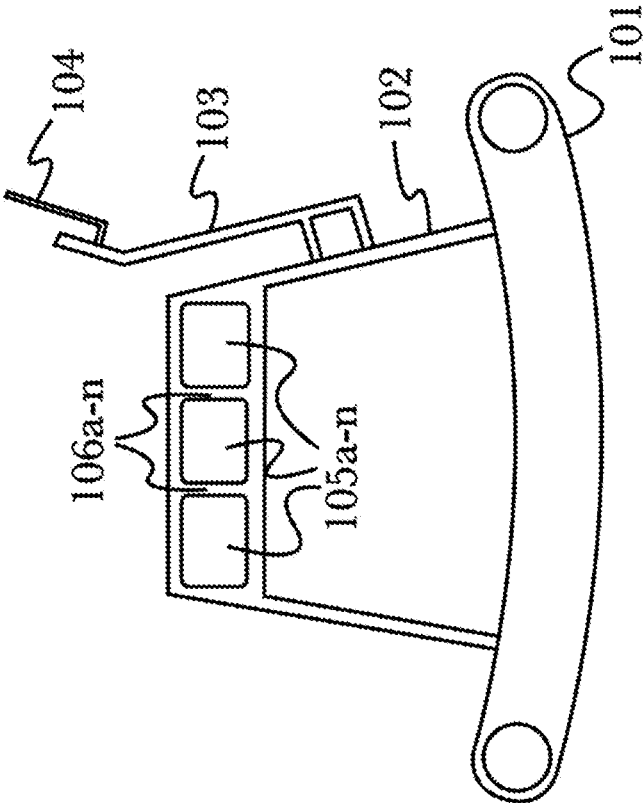

100

Fig. 1

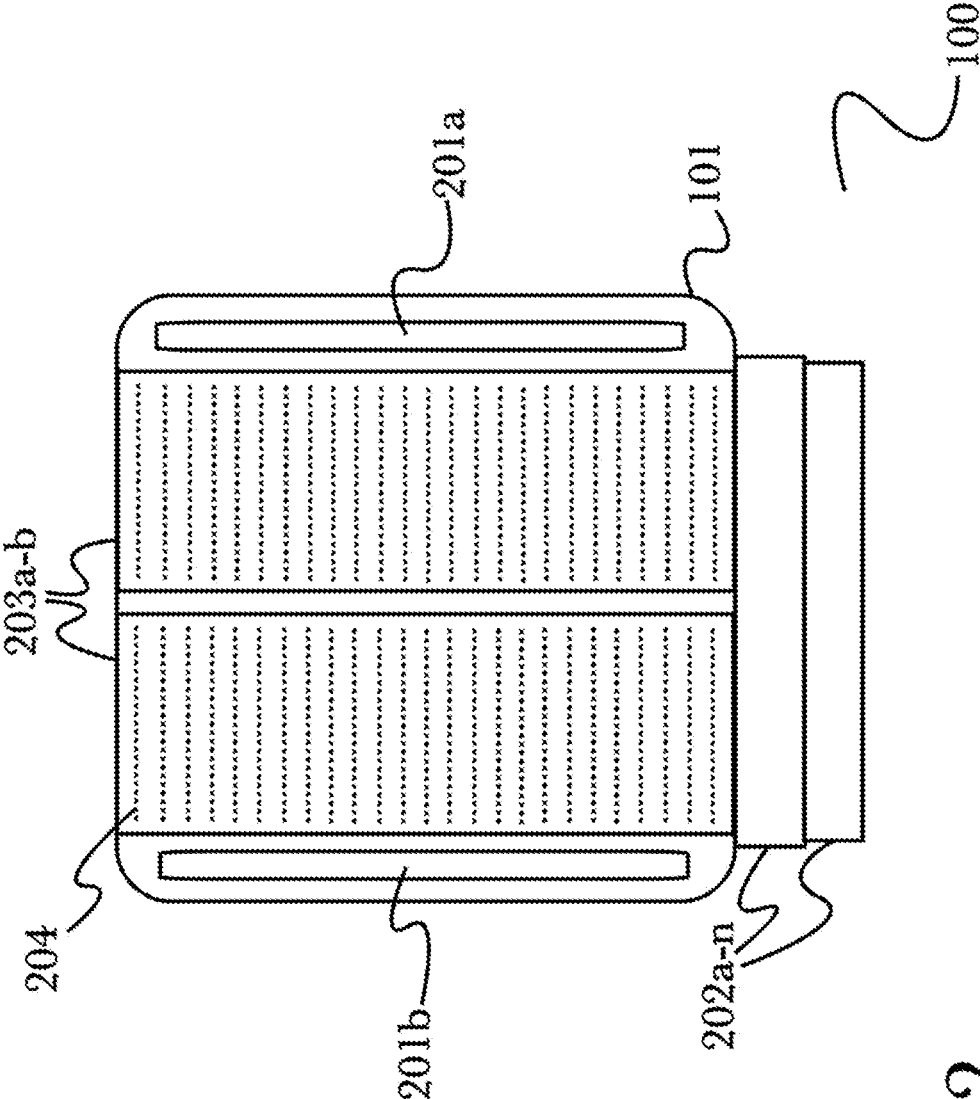

Fig. 2

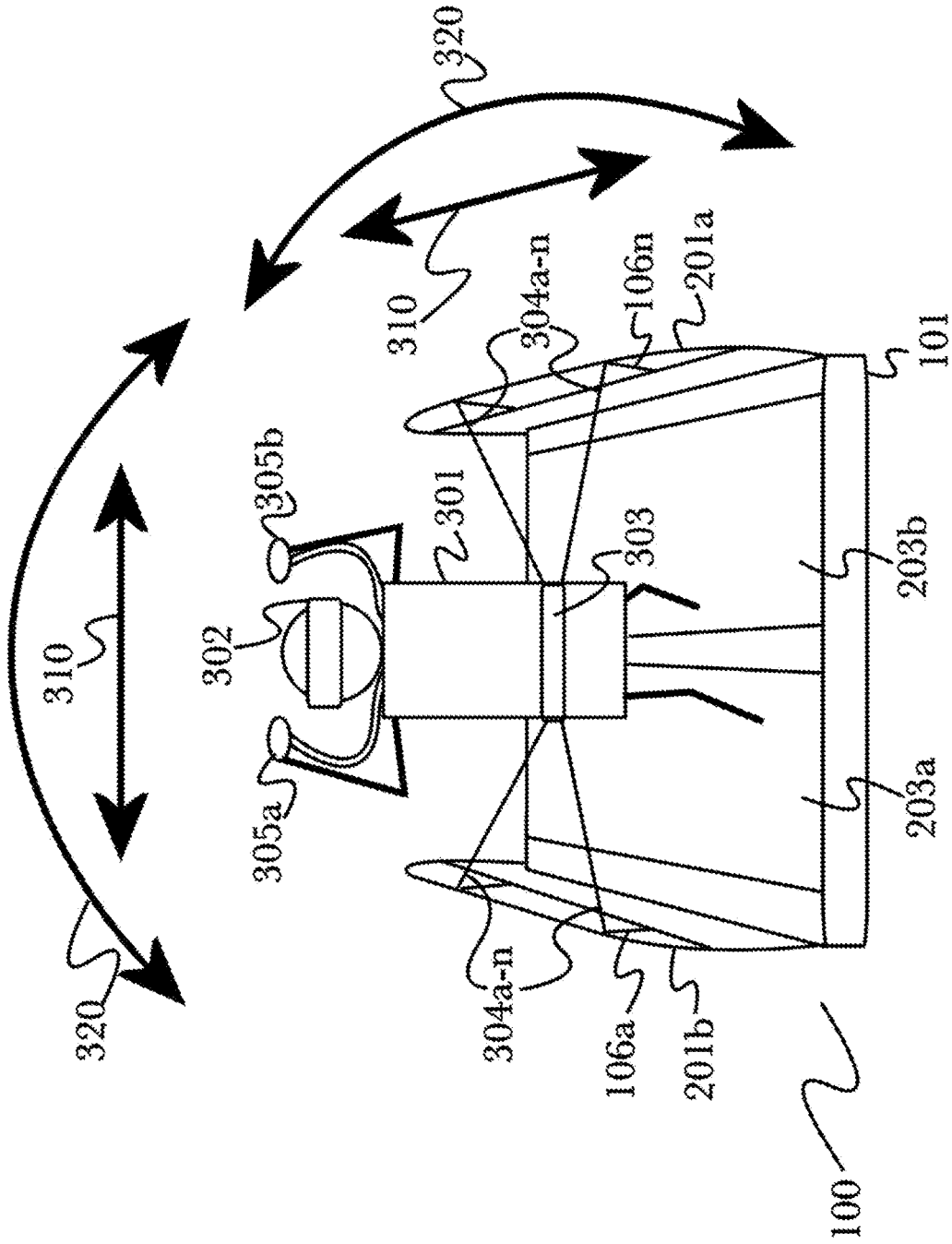

Fig. 3

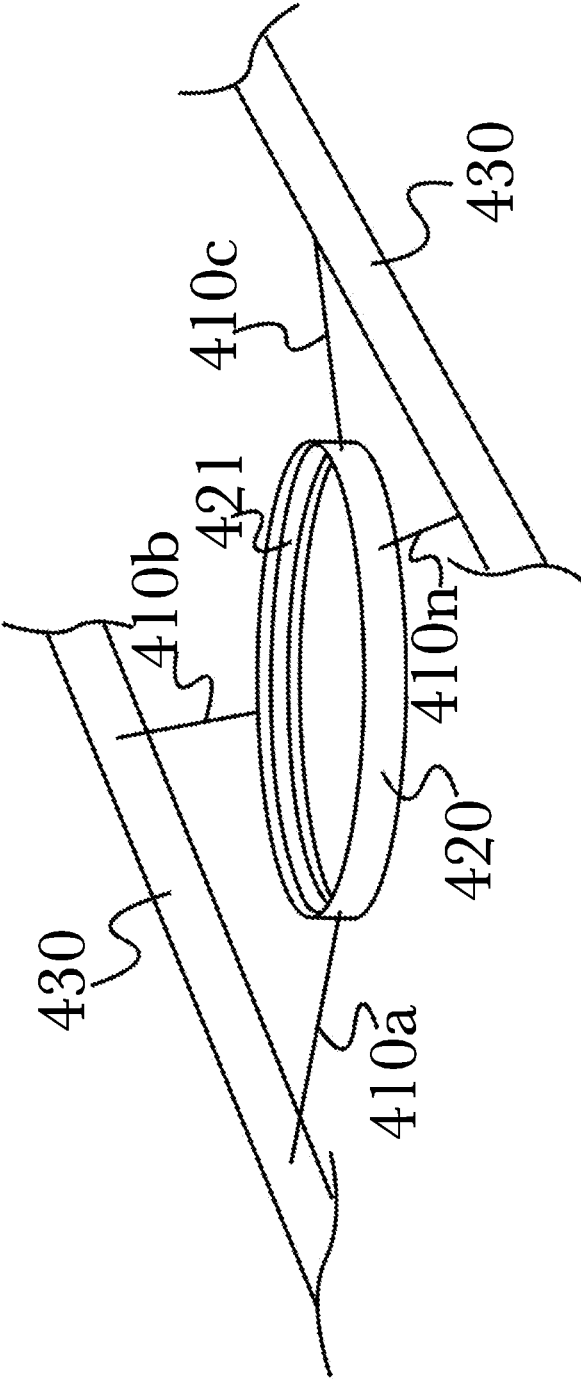

Fig. 4

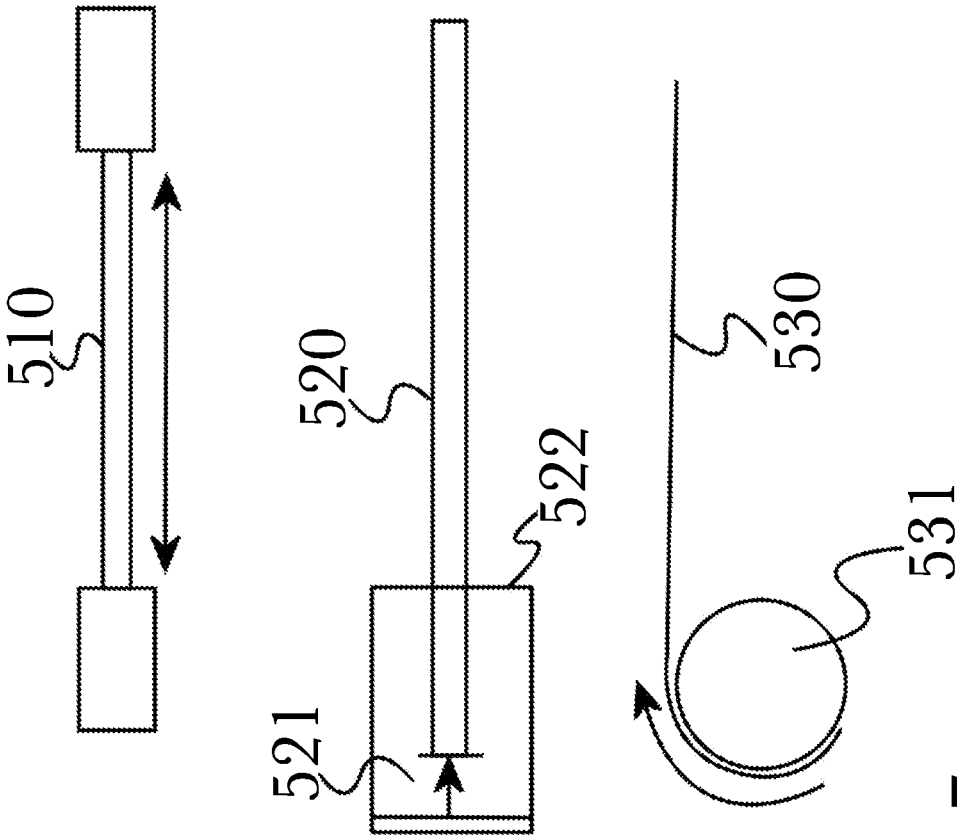

Fig. 5

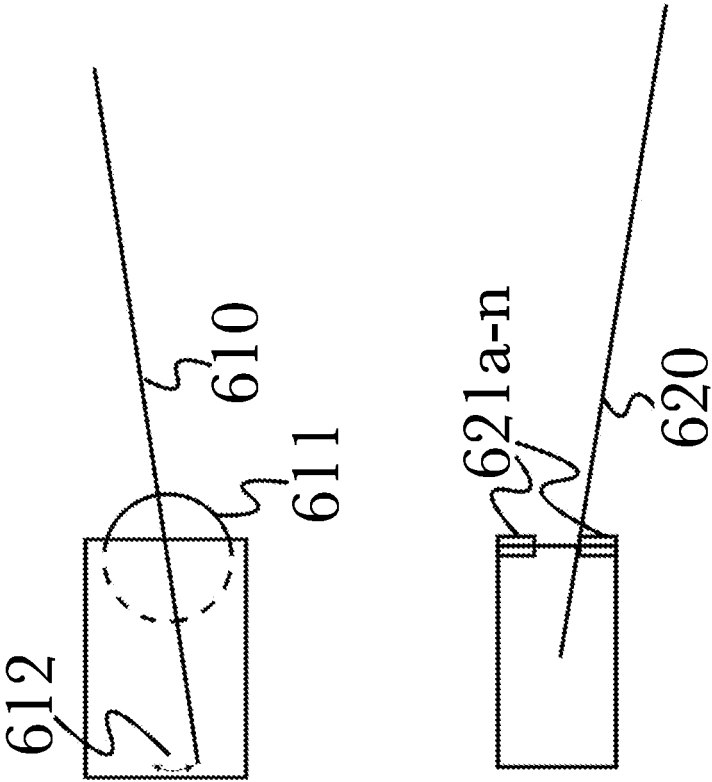

Fig. 6

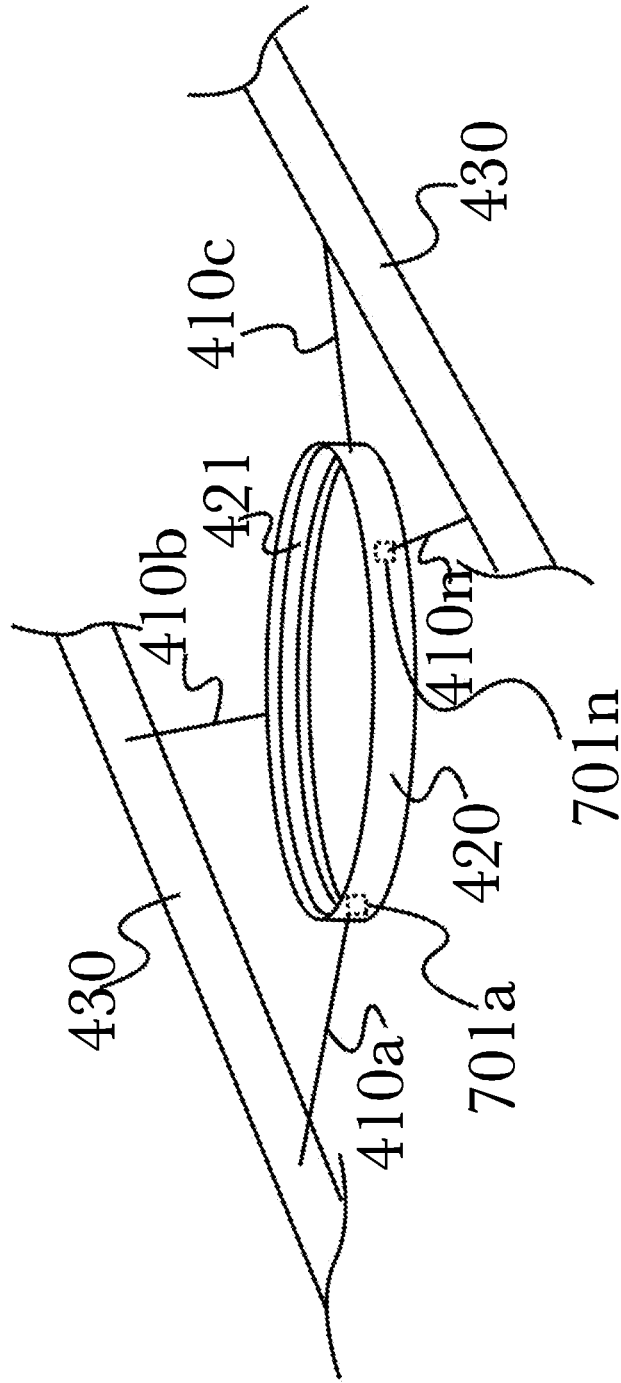

Fig. 7

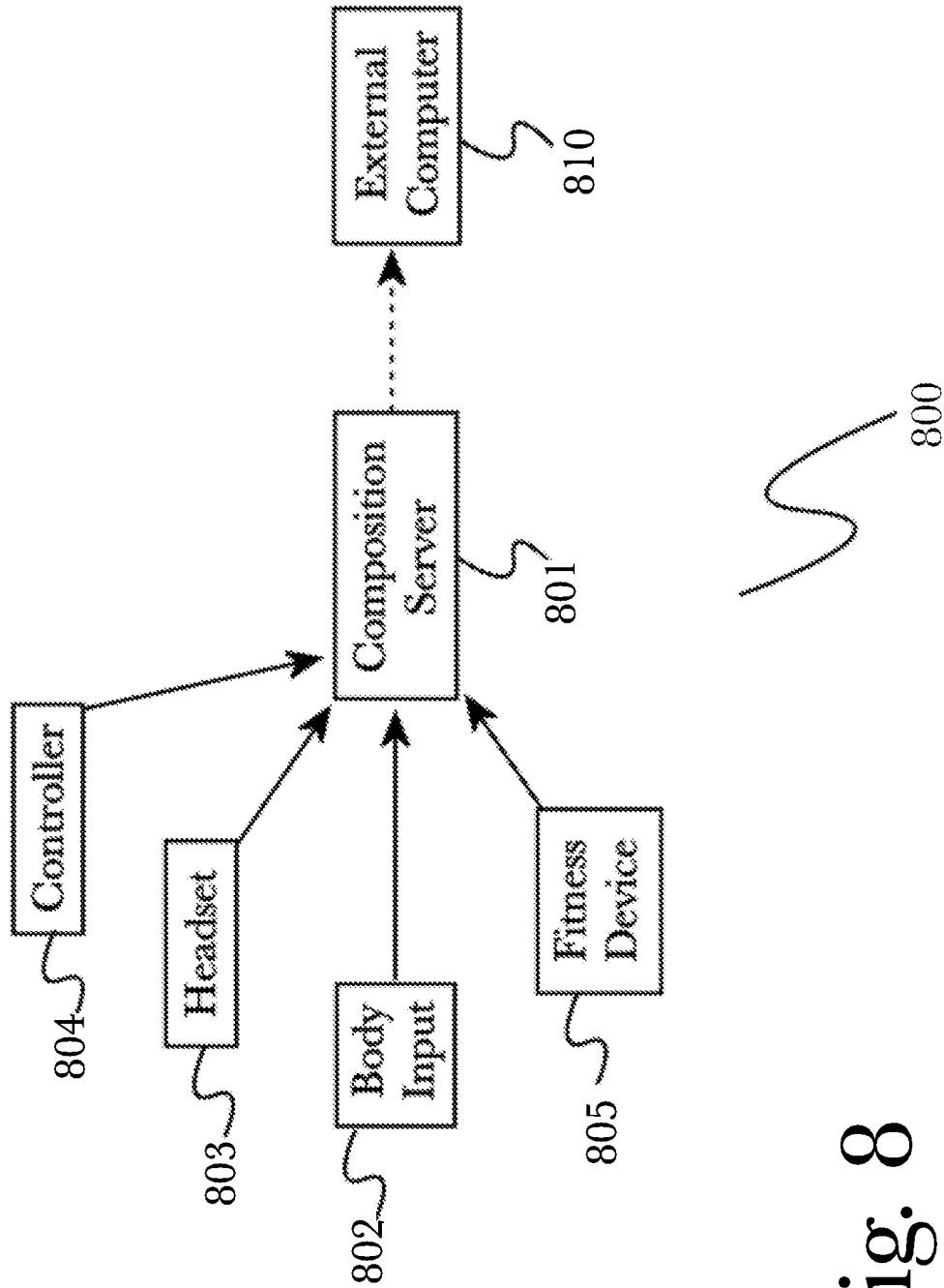

Fig. 8

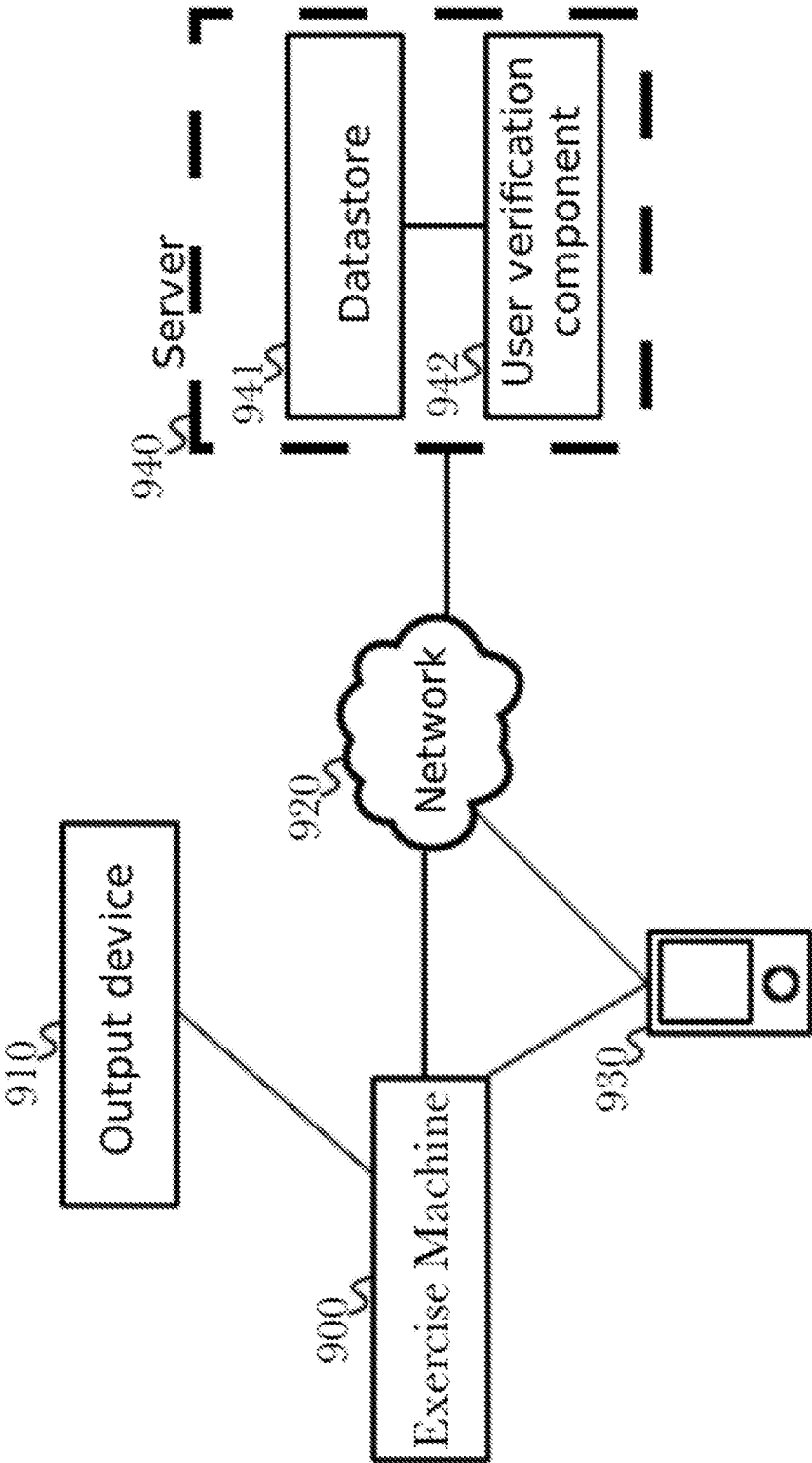

Fig. 9

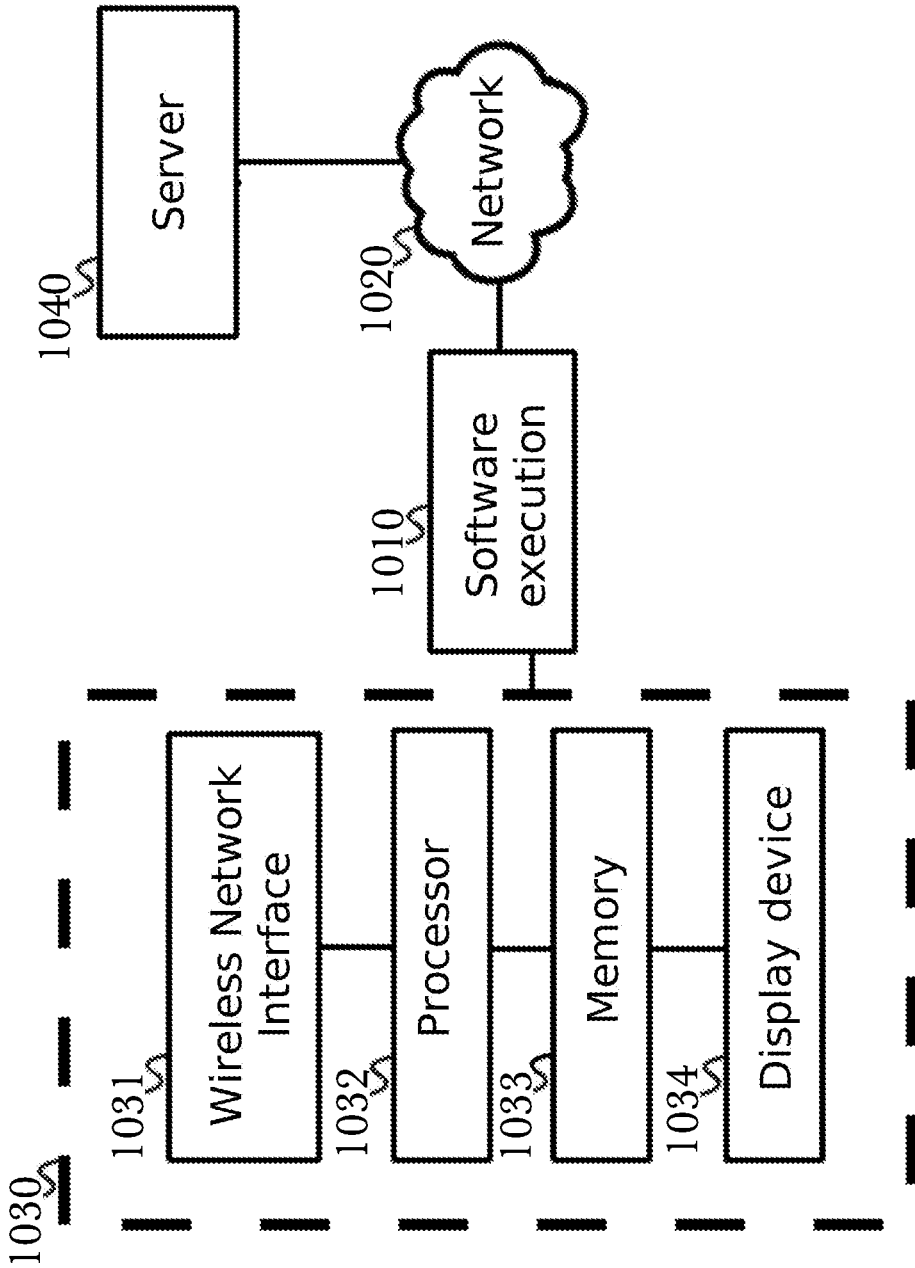

Fig. 10

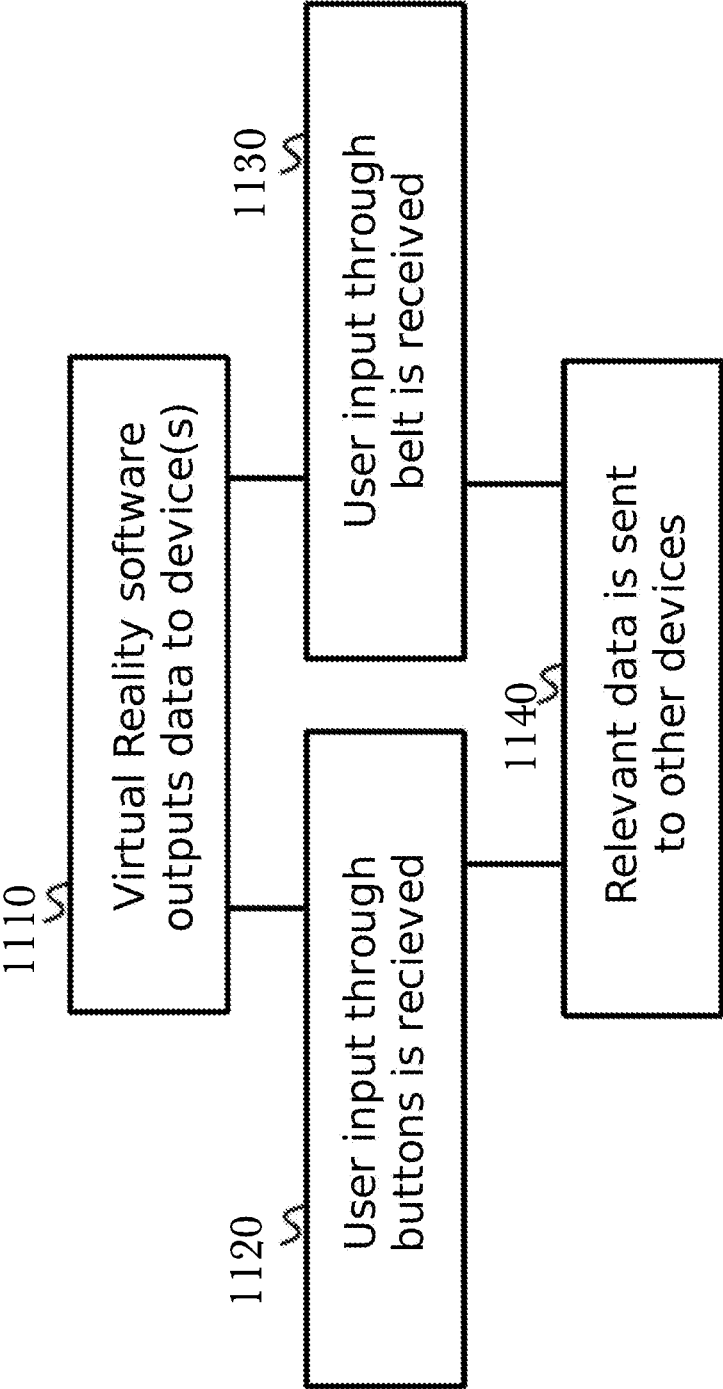

Fig. 11

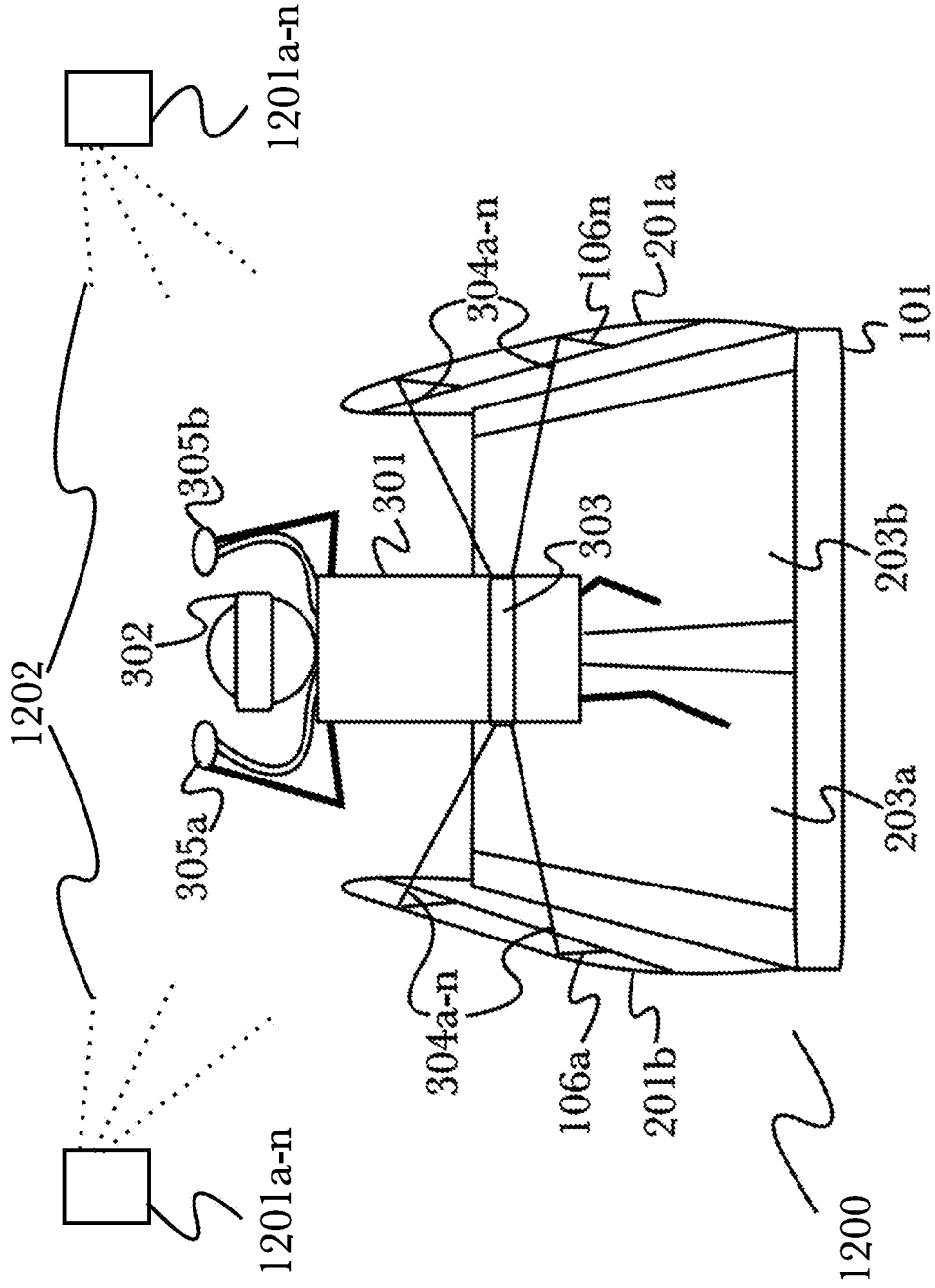

Fig. 12

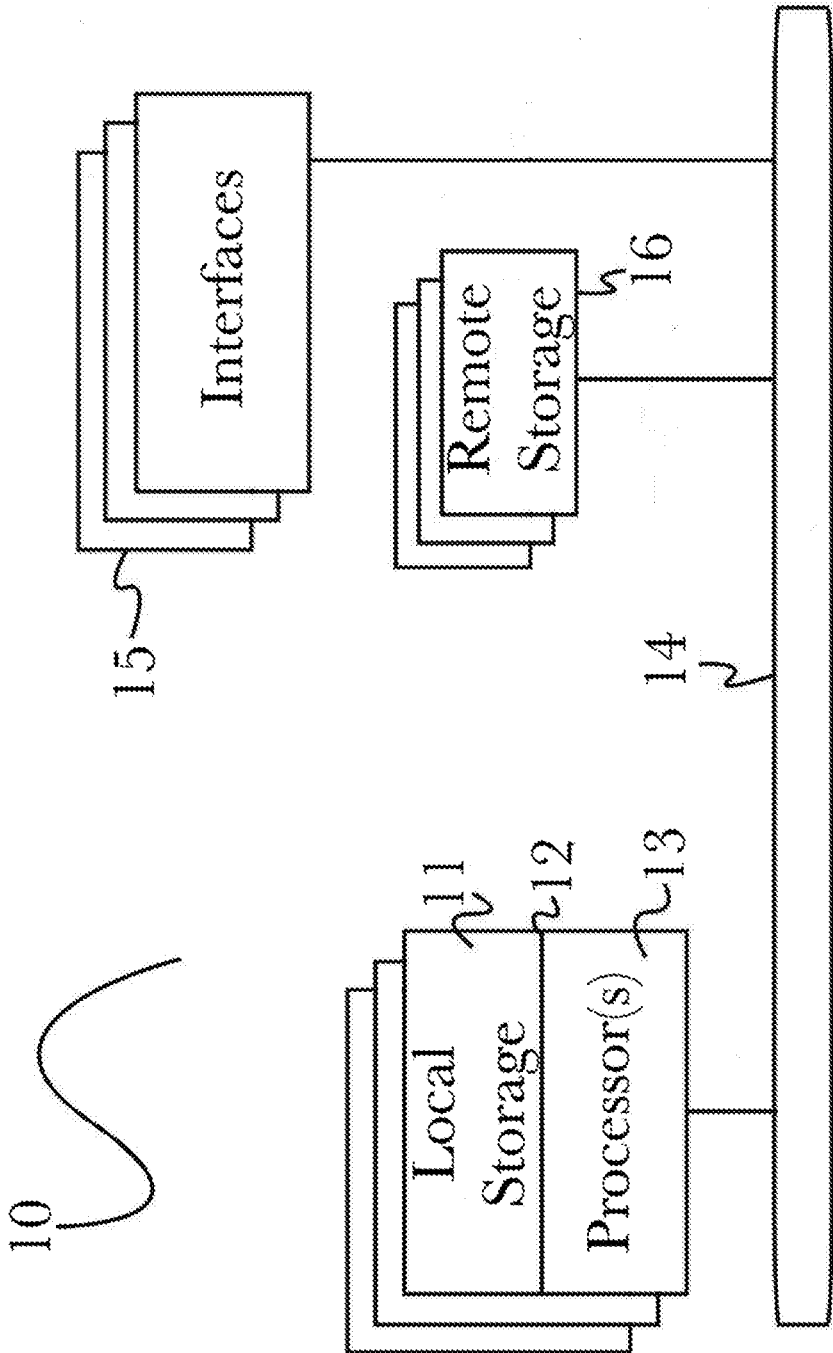

Fig. 13

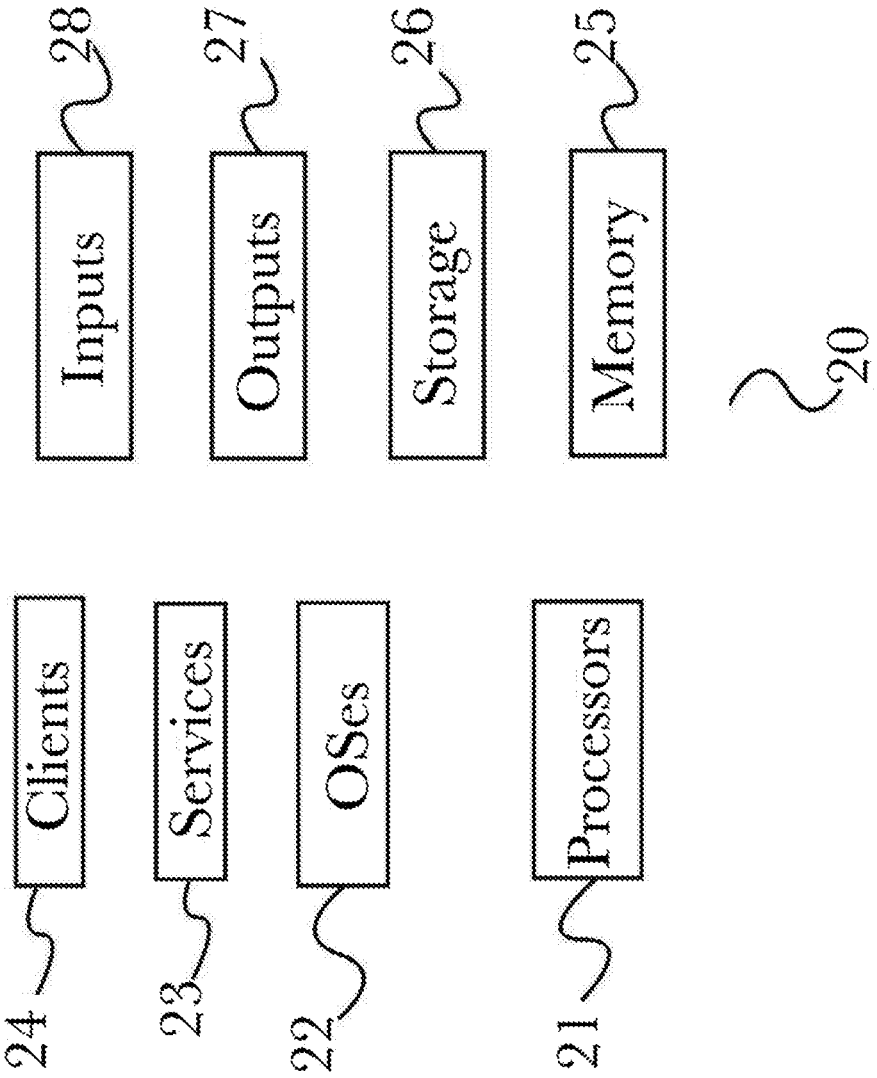

Fig. 14

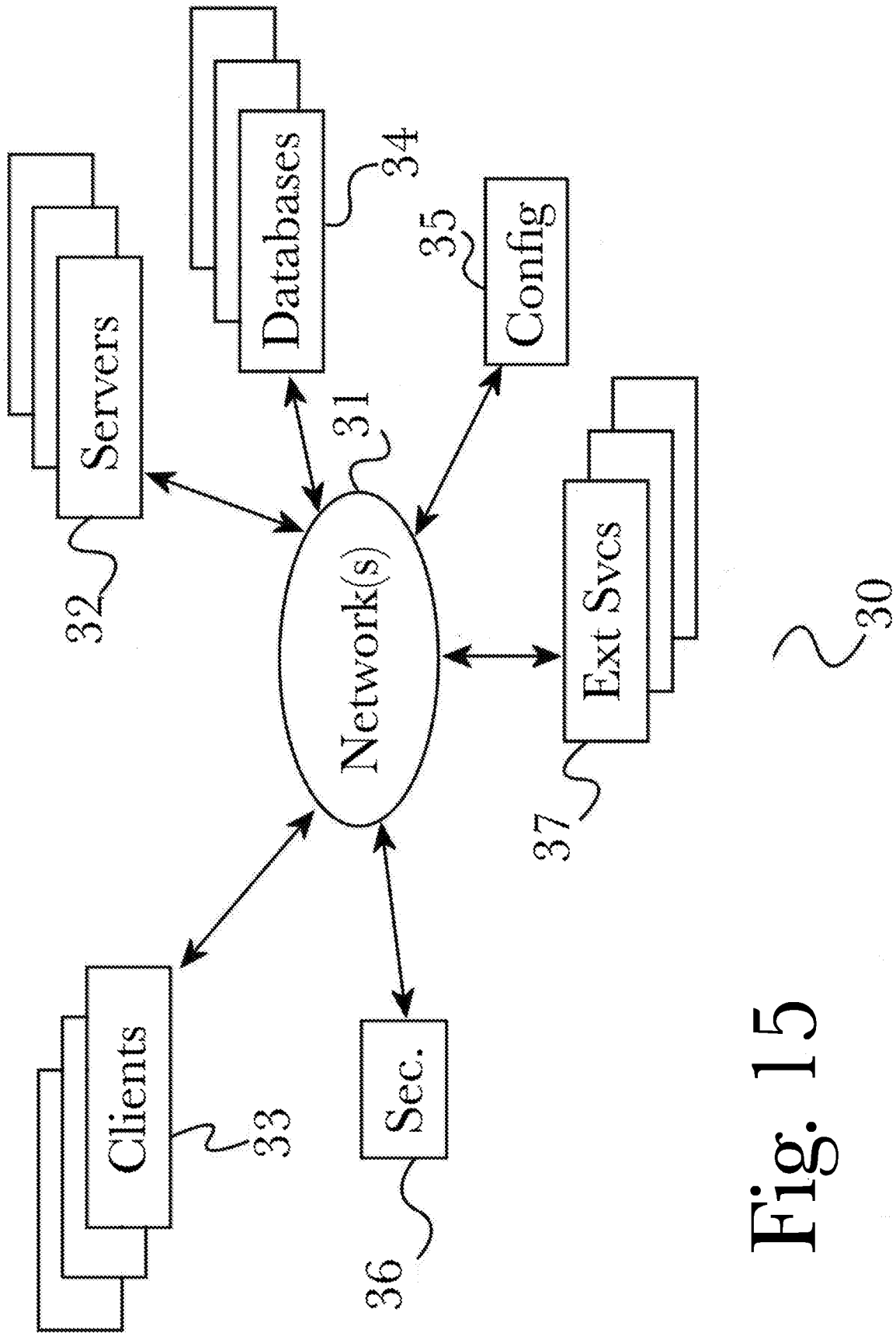

Fig. 15

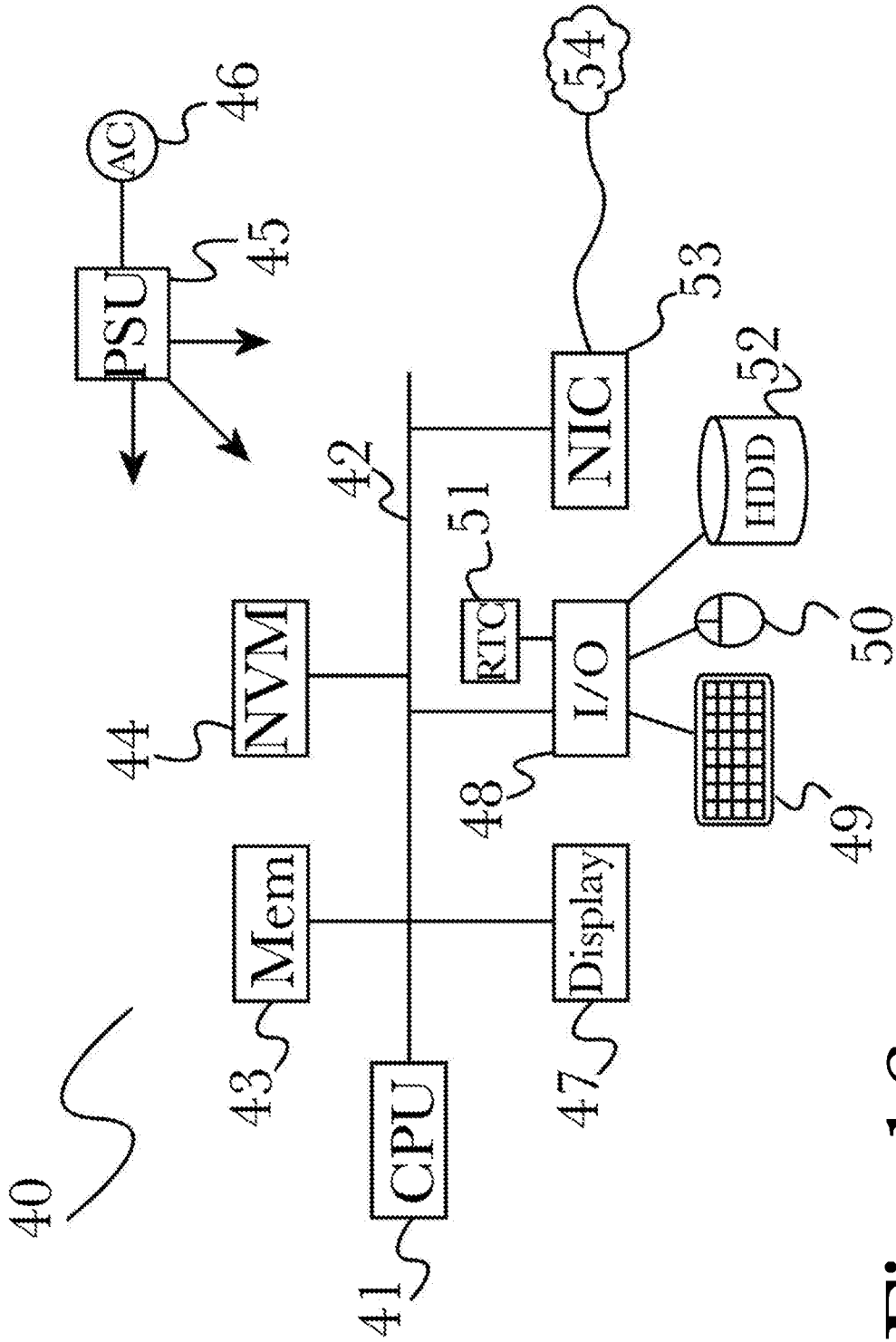

Fig. 16

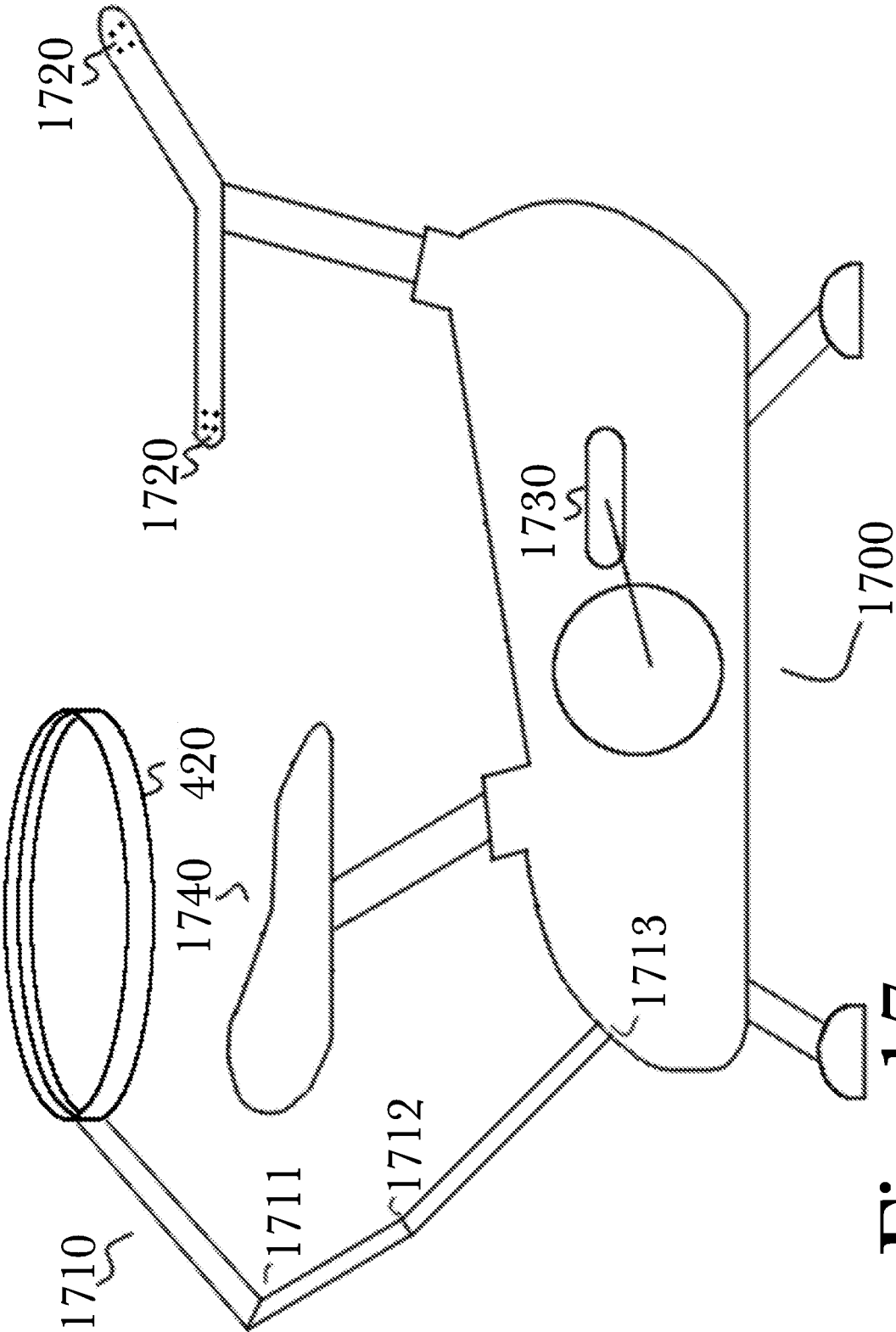

Fig. 17

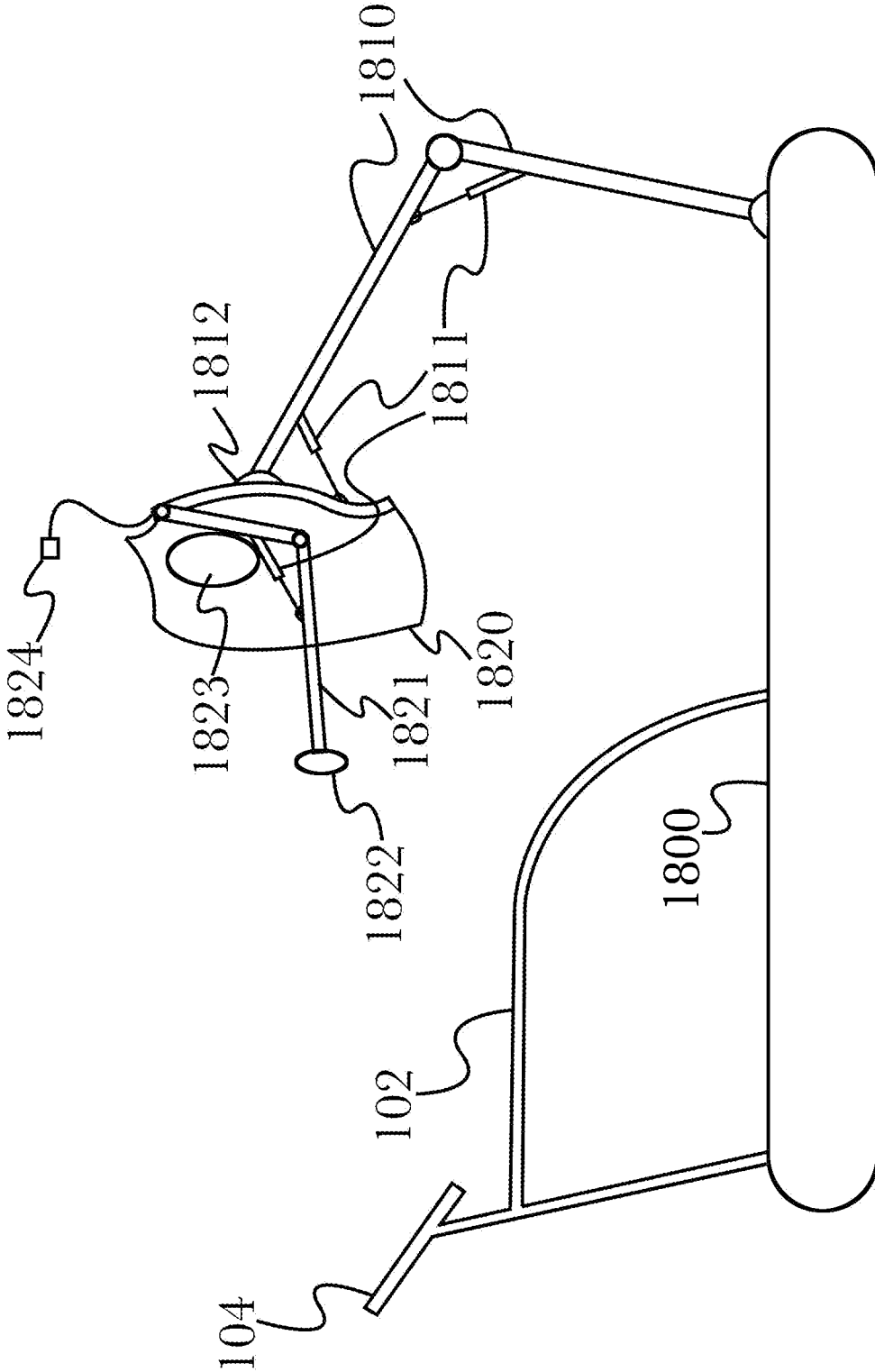

Fig. 18

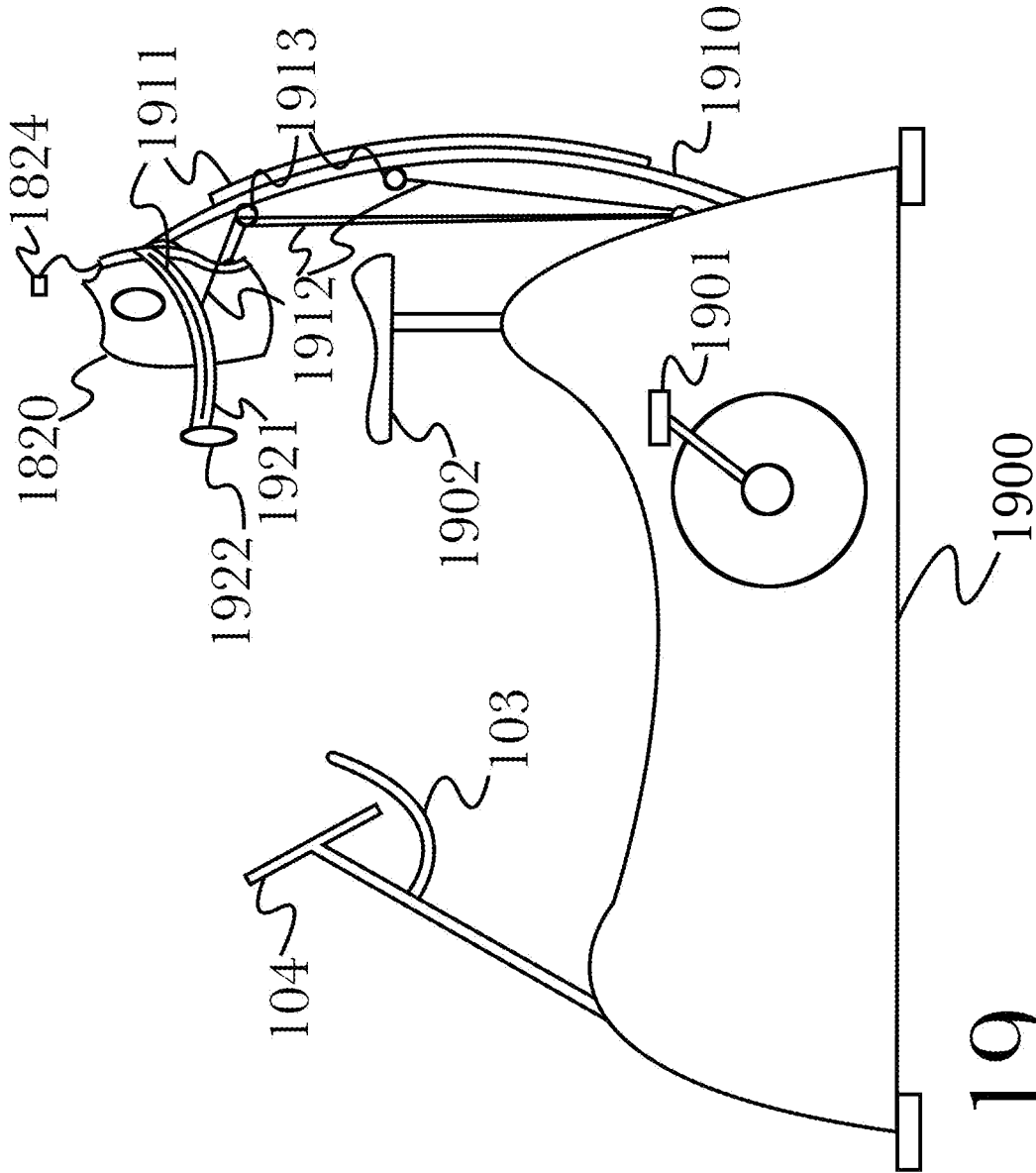

Fig. 19

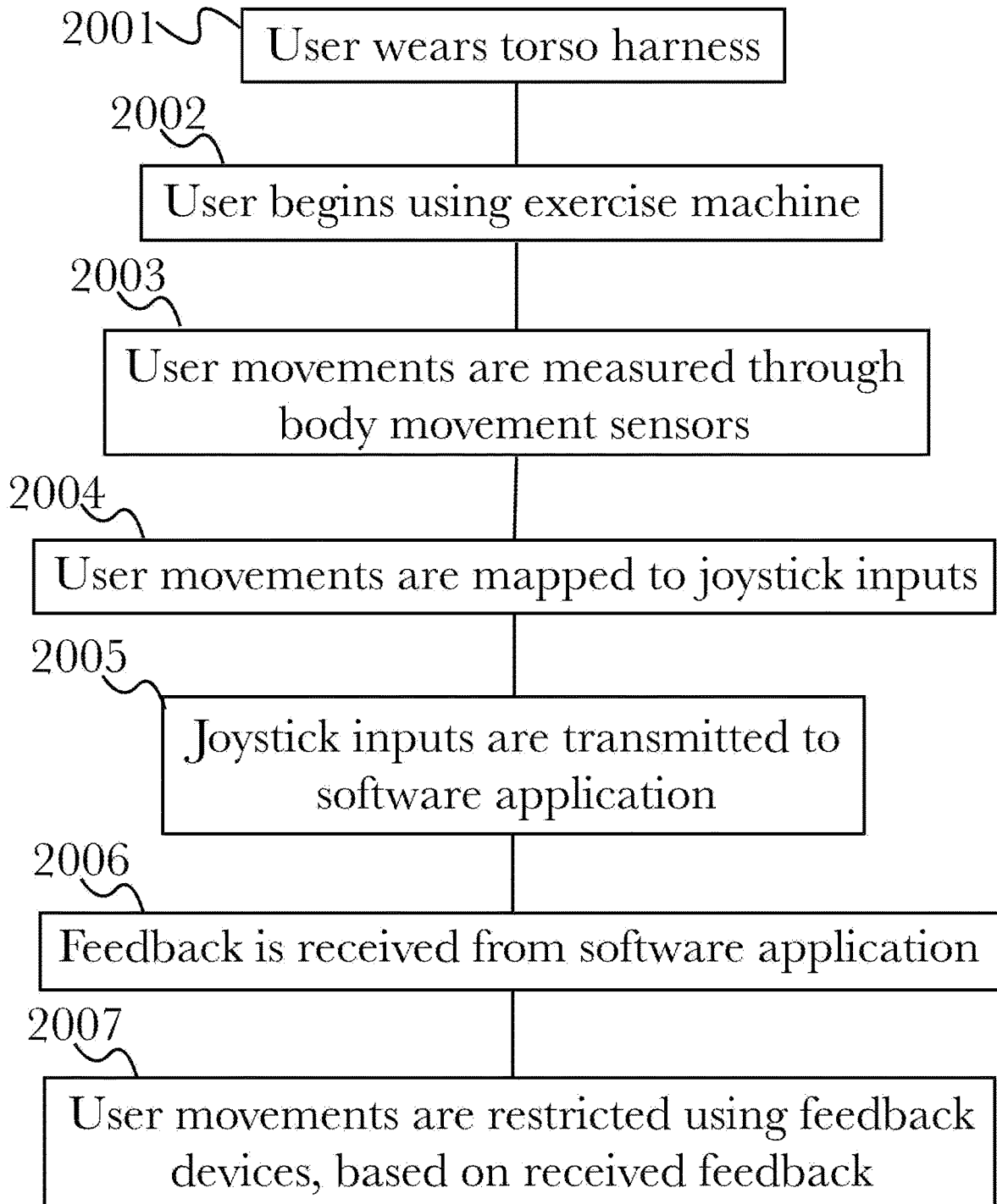

Fig. 20

2000

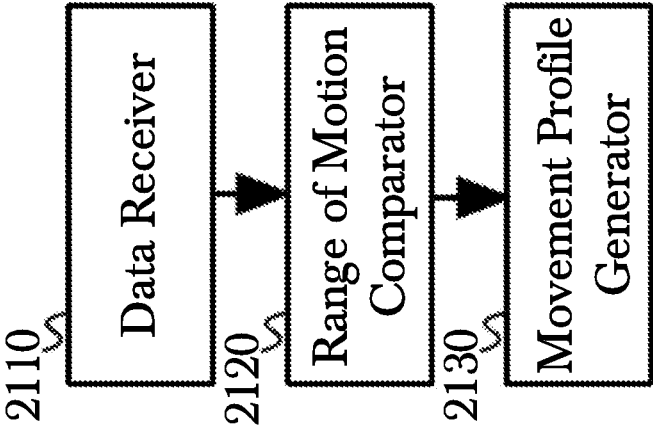

Fig. 21

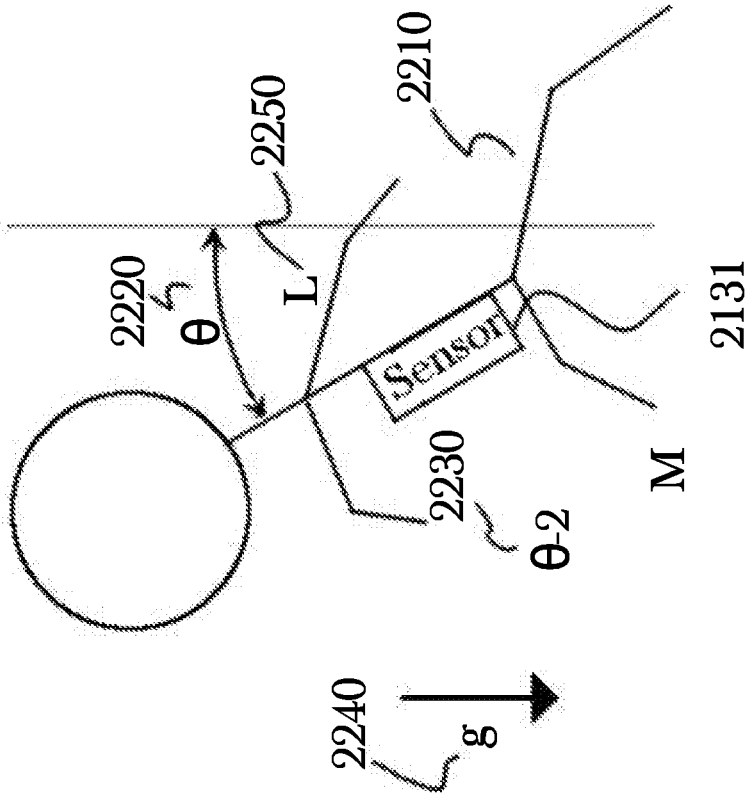

Fig. 22

Movement Profile Generator

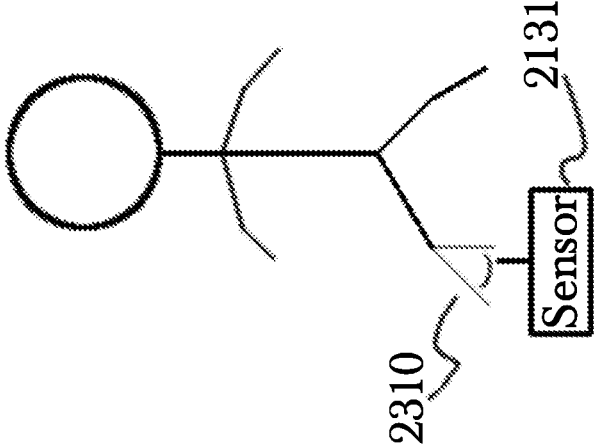

Fig. 23

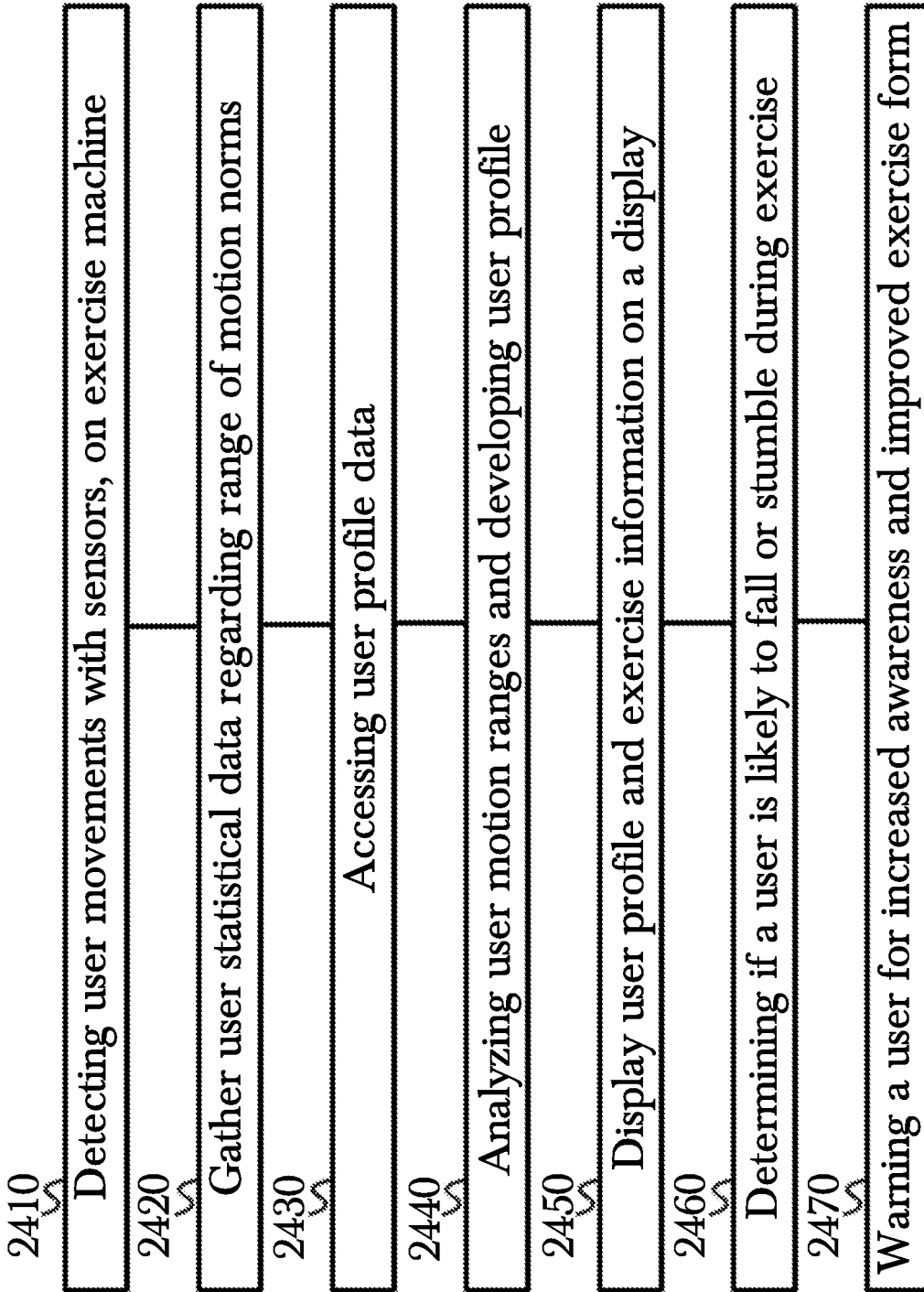

Fig. 24

SYSTEM AND METHOD FOR RANGE OF MOTION ANALYSIS AND BALANCE TRAINING WHILE EXERCISING

-continued

CROSS-REFERENCE TO RELATED APPLICATIONS

[0001]

application No.	Date Filed	Title
Current application	Herewith	A SYSTEM AND METHOD FOR RANGE OF MOTION ANALYSIS AND BALANCE TRAINING WHILE EXERCISING Is a continuation-in-part of:
16/793,915	Feb. 18, 2020	SYSTEM AND METHOD FOR RANGE OF MOTION ANALYSIS AND BALANCE TRAINING WHILE EXERCISING which is a continuation-in-part of:
16/255,641 Pat.	Jan. 23, 2019 Issue Date	SYSTEM AND METHOD FOR RANGE OF MOTION ANALYSIS AND BALANCE TRAINING WHILE EXERCISING
10,561,900	Feb. 18, 2020	BALANCE TRAINING WHILE EXERCISING which is a continuation of:
16/223,034	Jan. 23, 2019	SYSTEM AND METHOD FOR RANGE OF MOTION ANALYSIS AND BALANCE TRAINING WHILE EXERCISING which claims benefit of and priority to:
62/697,973	Jul. 13, 2018	VARIABLE-RESISTANCE EXERCISE MACHINE WITH WIRELESS COMMUNICATION FOR SMART DEVICE CONTROL AND INTERACTIVE SOFTWARE APPLICATIONS and is also a continuation-in-part of:
16/176,511	Oct. 31, 2018	VIRTUAL REALITY AND MIXED REALITY ENHANCED EXERCISE MACHINE which is a continuation-in-part of:
16/011,394 Pat.	Jun. 18, 2018 Issue Date	SYSTEM AND METHOD FOR A MIXED OR VIRTUAL REALITY-ENHANCED STATIONARY EXERCISE BICYCLE
10,155,133	Dec. 18, 2018	ENHANCED STATIONARY EXERCISE BICYCLE which is a continuation-in-part of:
15/853,746 Pat.	Dec. 23, 2017 Issue Date	VARIABLE-RESISTANCE EXERCISE MACHINE WITH WIRELESS COMMUNICATION FOR SMART DEVICE CONTROL AND INTERACTIVE SOFTWARE APPLICATIONS
10,265,578	Apr. 23, 2019	COMMUNICATION FOR SMART DEVICE CONTROL AND INTERACTIVE SOFTWARE APPLICATIONS which is a continuation of:
15/219,115 Pat.	Jul. 25, 2016 Issue Date	VARIABLE-RESISTANCE EXERCISE MACHINE WITH WIRELESS COMMUNICATION FOR SMART DEVICE CONTROL AND VIRTUAL REALITY APPLICATIONS
9,849,333	Dec. 26, 2017	COMMUNICATION FOR SMART DEVICE CONTROL AND VIRTUAL REALITY APPLICATIONS which claims benefit of, and priority to:
62/330,642	May 2, 2016	VARIABLE-RESISTANCE EXERCISE MACHINE WITH WIRELESS COMMUNICATION FOR SMART DEVICE CONTROL AND VIRTUAL REALITY APPLICATIONS and is also a continuation of:

application No.	Date Filed	Title
15/193,112	Jun. 27, 2016	NATURAL BODY INTERACTION FOR MIXED OR VIRTUAL REALITY APPLICATIONS which claims benefit of and priority to:
62/330,602	May 2, 2016	NATURAL BODY INTERACTION FOR MIXED OR VIRTUAL REALITY APPLICATIONS and is also a continuation-in-part of:
15/187,787 Pat.	Jun. 21, 2016 Issue Date	MULTIPLE ELECTRONIC CONTROL AND TRACKING DEVICES FOR MIXED-REALITY INTERACTION
10,124,255	Nov. 13, 2018	MIXED-REALITY INTERACTION which is a continuation-in-part of:
15/175,043 Pat.	Jun. 7, 2016 Issue Date	APPARATUS FOR NATURAL TORSO TRACKING AND FEEDBACK FOR ELECTRONIC INTERACTION
9,766,696	Sep. 19, 2017	ELECTRONIC INTERACTION which claims benefit of and priority to:
62/310,568	Mar. 18, 2016	APPARATUS FOR NATURAL TORSO TRACKING AND FEEDBACK FOR ELECTRONIC INTERACTION
Current application	Herewith	A SYSTEM AND METHOD FOR RANGE OF MOTION ANALYSIS AND BALANCE TRAINING WHILE EXERCISING Is a continuation-in-part of:
16/793,915	Feb. 18, 2020	SYSTEM AND METHOD FOR RANGE OF MOTION ANALYSIS AND BALANCE TRAINING WHILE EXERCISING which is a continuation-in-part of:
16/255,641 Pat.	Jan. 23, 2019 Issue Date	SYSTEM AND METHOD FOR RANGE OF MOTION ANALYSIS AND BALANCE TRAINING WHILE EXERCISING
10,561,900	Feb. 18, 2020	AND BALANCE TRAINING WHILE EXERCISING which is a continuation of:
16/223,034	Jan. 23, 2019	SYSTEM AND METHOD FOR RANGE OF MOTION ANALYSIS AND BALANCE TRAINING WHILE EXERCISING which is a continuation-in-part of:
16/255,641 Pat.	Jan. 23, 2019 Issue Date	SYSTEM AND METHOD FOR RANGE OF MOTION ANALYSIS AND BALANCE TRAINING WHILE EXERCISING
10,561,900	Feb. 18, 2020	AND BALANCE TRAINING WHILE EXERCISING which is a continuation of:
16/223,034	Jan. 23, 2019	SYSTEM AND METHOD FOR RANGE OF MOTION ANALYSIS AND BALANCE TRAINING WHILE EXERCISING which is a continuation-in-part of:
16/176,511	Oct. 31, 2018	VIRTUAL REALITY AND MIXED REALITY ENHANCED EXERCISE MACHINE which is a continuation-in-part of:
16/011,394 Pat.	Jun. 18, 2018 Issue Date	SYSTEM AND METHOD FOR A MIXED OR VIRTUAL REALITY-ENHANCED STATIONARY EXERCISE BICYCLE
10,155,133	Dec. 18, 2018	ENHANCED STATIONARY EXERCISE BICYCLE which is a continuation-in-part of:
15/853,746 Pat.	Dec. 23, 2017 Issue Date	VARIABLE-RESISTANCE EXERCISE MACHINE WITH WIRELESS COMMUNICATION FOR SMART DEVICE CONTROL AND INTERACTIVE SOFTWARE APPLICATIONS
10,265,578	Apr. 23, 2019	COMMUNICATION FOR SMART DEVICE CONTROL AND INTERACTIVE SOFTWARE APPLICATIONS which is a continuation of:
15/219,115 Pat.	Jul. 25, 2016 Issue Date	VARIABLE-RESISTANCE EXERCISE MACHINE WITH WIRELESS COMMUNICATION FOR SMART DEVICE CONTROL AND VIRTUAL REALITY APPLICATIONS
9,849,333	Dec. 26, 2017	COMMUNICATION FOR SMART DEVICE CONTROL AND VIRTUAL REALITY APPLICATIONS which is a continuation of:
15/193,112	Jun. 27, 2016	NATURAL BODY INTERACTION FOR MIXED OR VIRTUAL REALITY APPLICATIONS which is a continuation-in-part of:
15/187,787 Pat.	Jun. 21, 2016 Issue Date	MULTIPLE ELECTRONIC CONTROL AND TRACKING DEVICES FOR MIXED- REALITY INTERACTION
10,124,255	Nov. 13, 2018	MIXED- REALITY INTERACTION which is a continuation-in-part of:

-continued

application No.	Date Filed	Title
14/846,966 Pat.	Sep. 7, 2015 Issue Date	MULTIPLE ELECTRONIC CONTROL DEVICES
10,080,958	Sep. 25, 2018	and is also a continuation-in- part of:
14/012,879	Aug. 28, 2013	Mobile and Adaptable Fitness System which claims benefit of, and priority to:
61/696,068	Aug. 31, 2012	Mobile and Adaptable Fitness System

the entire specification of each of which is incorporated herein by reference.

BACKGROUND OF THE INVENTION

Field of the Art

[0002] The disclosure relates to the field of health and fitness devices, and more particularly to the field of devices designed to provide feedback regarding range of motion and balance.

Discussion of the State of the Art

[0003] It is currently the case that exercising machines and systems exist that allow individuals of many different physical abilities to exercise many different parts of their body, or their entire body, at once. Some systems that allow this integrate with phone systems and some manner of online user profile, or a local user profile, which allows users to keep track of exercise they have completed or their approximate fitness level based on their performance. However, for elderly and at-risk individuals, there are no systems which simultaneously may be capable of warning an individual if they are about to stumble or fall based on posture or exercise performance, or help train their balance by providing feedback and warnings so that such stumbles and falls do not take place. Elderly and at-risk individuals may for example, take advantage of a treadmill, but there is currently no treadmill or walking exercise device which warns or assists a user in training their balance if they are prone to falling or stumbling during routine exercise. This proves to be a problem for many individuals who need to continue routine exercise but who may have difficulty performing it for physical reasons.

[0004] What is needed then, is a system and method for range of motion analysis and balance training while exercising.

SUMMARY OF THE INVENTION

[0005] Accordingly, the inventor has conceived and reduced to practice, a system and method range of motion analysis and balance training while exercising.

[0006] According to a preferred embodiment, a system for range of motion analysis and balance training while exercising has been devised, comprising: an exercise machine; and a first sensor connected to or integrated into the exercise machine, and configured to detect the angle of a user's torso away from vertical; and at least one additional sensor connected to or integrated into the exercise machine configured to detect the range of motion of at least one portion of the user's body; and a range of motion analyzer, comprising at least a plurality of programming instructions stored in the memory of, and operating on at least one processor of, a computing device, wherein the plurality of programming instructions, when operating on the processor,

cause the computing device to: receive data from the at least one additional sensor; receive or obtain statistical data regarding range of motion norms for people of different ages; receive or obtain stored user profile data for the current user of the compatible exercise machine; perform a plurality of analyses of the user's range of motion; create a profile of the user's range of motion relative to statistical norms, prior history, and the virtual reality or mixed reality environment associated with the user's exercise; display the results to the user in graphical or textual form; and a balance trainer, comprising at least a plurality of programming instructions stored in the memory of, and operating on at least one processor of, a computing device, wherein the plurality of programming instructions, when operating on the processor, cause the computing device to: receive data from the first sensor; calculate, based on the data from the first sensor and the rate of change of that data, when the user is likely to stumble or fall; and display a warning to the user in graphical or textual form to train the user to learn to anticipate and correct stumbles and falls.

[0007] A method for range of motion analysis and balance training while exercising has been devised, comprising the steps of: detecting and characterizing the angle of a user's torso away from vertical position, using a sensor and exercise machine; detecting and characterizing the range of motion of at least one portion of a user's body, using an additional sensor and an exercise machine; receiving or obtaining statistical data regarding range of motion norms for people of different ages, using a range of motion analyzer; receiving or obtaining stored user profile data for the current user of the compatible exercise machine, using a range of motion analyzer; performing a plurality of analyses of the user's range of motion, using a range of motion analyzer; creating a profile of the user's range of motion relative to statistical norms, prior history, and the virtual reality or mixed reality environment associated with the user's exercise, using a range of motion analyzer; displaying the results to the user in graphical or textual form; informing a user if they are likely to fall, based at least in part on data from the first sensor and the rate of change of that data, using a balance trainer and a first sensor; and displaying a warning to a user in graphical or textual form in order to improve a user's ability to anticipate and correct stumbles or falls through improved exercise form, using a balance trainer and display.

BRIEF DESCRIPTION OF THE DRAWING FIGURES

[0008] The accompanying drawings illustrate several embodiments of the invention and, together with the description, serve to explain the principles of the invention according to the embodiments. It will be appreciated by one skilled in the art that the particular embodiments illustrated in the drawings are merely exemplary, and are not to be considered as limiting of the scope of the invention or the claims herein in any way.

[0009] FIG. 1 is a side view of an exemplary variable-resistance exercise machine with wireless communication for smart device control and interactive software applications, according to a preferred embodiment of the invention.

[0010] FIG. 2 is a top-down view of an exemplary variable-resistance exercise machine with wireless communica-

tion for smart device control and interactive software applications, according to a preferred embodiment of the invention.

[0011] FIG. 3 is a diagram illustrating an exemplary system for a virtual reality or mixed reality enhanced exercise machine, illustrating the use of a plurality of connected smart devices and tethers, and showing interaction via the user's body as a control stick.

[0012] FIG. 4 is a diagram of an exemplary apparatus for natural torso tracking and feedback for electronic interaction, illustrating the use of multiple tethers and a movable torso harness.

[0013] FIG. 5 is a diagram illustrating a variety of alternate tether arrangements.

[0014] FIG. 6 is a diagram of an additional exemplary apparatus for natural torso tracking and feedback for electronic interaction, illustrating the use of angle sensors to detect angled movement of tethers.

[0015] FIG. 7 is a diagram illustrating an exemplary apparatus for natural torso tracking and feedback for electronic interaction, illustrating the use of multiple tethers and a movable torso harness comprising a plurality of angle sensors positioned within the movable torso harness.

[0016] FIG. 8 is a block diagram of an exemplary system architecture for natural body interaction for mixed or virtual reality applications.

[0017] FIG. 9 is a block diagram of an exemplary system architecture for a stationary exercise bicycle being connected over local connections to a smartphone, an output device other than a phone, and a server over a network, according to an aspect.

[0018] FIG. 10 is a diagram of an exemplary hardware arrangement of a smart phone or computing device running a user identification component and communicating over a network, according to an aspect.

[0019] FIG. 11 is a block diagram of a method of mixed or virtual reality software operating to receive input through different sources, and send output to devices, according to an aspect.

[0020] FIG. 12 is a diagram illustrating an exemplary virtual reality or mixed reality enhanced exercise machine, illustrating the use of a plurality of optical sensors to detect body movement of a user during use of an exercise machine.

[0021] FIG. 13 is a block diagram illustrating an exemplary hardware architecture of a computing device.

[0022] FIG. 14 is a block diagram illustrating an exemplary logical architecture for a client device.

[0023] FIG. 15 is a block diagram showing an exemplary architectural arrangement of clients, servers, and external services.

[0024] FIG. 16 is another block diagram illustrating an exemplary hardware architecture of a computing device.

[0025] FIG. 17 is a block diagram of an exemplary virtual reality or mixed reality enhanced exercise machine, illustrating the use of a stationary bicycle with hand controls on the handles, and a belt-like harness attachment.

[0026] FIG. 18 is a diagram of another exemplary virtual reality or mixed reality enhanced exercise machine, illustrating the use of a treadmill exercise machine with a vest-type harness with a plurality of pistons to provide a hardware-based torso joystick with full-body tracking.

[0027] FIG. 19 is a diagram of another exemplary virtual reality or mixed reality enhanced exercise machine, illus-

trating the use of a stationary bicycle with a vest-type harness with a plurality of strain sensors and tethers.

[0028] FIG. 20 is a flow diagram illustrating an exemplary method for operating a virtual and mixed-reality enhanced exercise machine.

[0029] FIG. 21 is a system diagram of a key components in the analysis of a user's range of motion and balance training, according to a preferred embodiment.

[0030] FIG. 22 is a system diagram of a user moving during exercise, in a form analogous to an inverted pendulum, according to a preferred aspect.

[0031] FIG. 23 is a system diagram of a sensor measuring the range of motion of a user during a specific exercise, according to a preferred aspect.

[0032] FIG. 24 is a method diagram illustrating behavior and performance of key components for range of motion analysis and balance training, according to a preferred aspect.

DETAILED DESCRIPTION

[0033] The inventor has conceived, and reduced to practice, a system and method for range of motion analysis while exercising.

[0034] One or more different inventions may be described in the present application. Further, for one or more of the inventions described herein, numerous alternative embodiments may be described; it should be appreciated that these are presented for illustrative purposes only and are not limiting of the inventions contained herein or the claims presented herein in any way. One or more of the inventions may be widely applicable to numerous embodiments, as may be readily apparent from the disclosure. In general, embodiments are described in sufficient detail to enable those skilled in the art to practice one or more of the inventions, and it should be appreciated that other embodiments may be utilized and that structural, logical, software, electrical and other changes may be made without departing from the scope of the particular inventions. Accordingly, one skilled in the art will recognize that one or more of the inventions may be practiced with various modifications and alterations. Particular features of one or more of the inventions described herein may be described with reference to one or more particular embodiments or figures that form a part of the present disclosure, and in which are shown, by way of illustration, specific embodiments of one or more of the inventions. It should be appreciated, however, that such features are not limited to usage in the one or more particular embodiments or figures with reference to which they are described. The present disclosure is neither a literal description of all embodiments of one or more of the inventions nor a listing of features of one or more of the inventions that must be present in all embodiments.

[0035] Headings of sections provided in this patent application and the title of this patent application are for convenience only, and are not to be taken as limiting the disclosure in any way.

[0036] Devices that are in communication with each other need not be in continuous communication with each other, unless expressly specified otherwise. In addition, devices that are in communication with each other may communicate directly or indirectly through one or more communication means or intermediaries, logical or physical.

[0037] A description of an embodiment with several components in communication with each other does not imply

that all such components are required. To the contrary, a variety of optional components may be described to illustrate a wide variety of possible embodiments of one or more of the inventions and in order to more fully illustrate one or more aspects of the inventions. Similarly, although process steps, method steps, algorithms or the like may be described in a sequential order, such processes, methods and algorithms may generally be configured to work in alternate orders, unless specifically stated to the contrary. In other words, any sequence or order of steps that may be described in this patent application does not, in and of itself, indicate a requirement that the steps be performed in that order. The steps of described processes may be performed in any order practical. Further, some steps may be performed simultaneously despite being described or implied as occurring non-simultaneously (e.g., because one step is described after the other step). Moreover, the illustration of a process by its depiction in a drawing does not imply that the illustrated process is exclusive of other variations and modifications thereto, does not imply that the illustrated process or any of its steps are necessary to one or more of the invention(s), and does not imply that the illustrated process is preferred. Also, steps are generally described once per embodiment, but this does not mean they must occur once, or that they may only occur once each time a process, method, or algorithm is carried out or executed. Some steps may be omitted in some embodiments or some occurrences, or some steps may be executed more than once in a given embodiment or occurrence.

[0038] When a single device or article is described herein, it will be readily apparent that more than one device or article may be used in place of a single device or article. Similarly, where more than one device or article is described herein, it will be readily apparent that a single device or article may be used in place of the more than one device or article.

[0039] The functionality or the features of a device may be alternatively embodied by one or more other devices that are not explicitly described as having such functionality or features. Thus, other embodiments of one or more of the inventions need not include the device itself.

[0040] Techniques and mechanisms described or referenced herein will sometimes be described in singular form for clarity. However, it should be appreciated that particular embodiments may include multiple iterations of a technique or multiple instantiations of a mechanism unless noted otherwise. Process descriptions or blocks in figures should be understood as representing modules, segments, or portions of code which include one or more executable instructions for implementing specific logical functions or steps in the process. Alternate implementations are included within the scope of embodiments of the present invention in which, for example, functions may be executed out of order from that shown or discussed, including substantially concurrently or in reverse order, depending on the functionality involved, as would be understood by those having ordinary skill in the art.

[0041] Conceptual Architecture

[0042] FIG. 1 is a side view of a variable-resistance exercise machine with wireless communication for smart device control and interactive software applications 100, according to a preferred embodiment of the invention. According to the embodiment, an exercise machine 100 may

have a stable base 101 to provide a platform for a user to safely stand or move about upon.

[0043] Additional safety may be provided through the use of a plurality of integrally-formed or detachable side rails 102, for example having safety rails on the left and right sides (with respect to a user's point of view) of exercise machine 100 to provide a stable surface for a user to grasp as needed. Additionally, side rails 102 may comprise a plurality of open regions 105a-n formed to provide additional locations for a user to grasp or for the attachment of additional equipment such as a user's smart device (not shown) through the use of a mountable or clamping case or mount. Formed or removable supports 106a-n may be used for additional grip or mounting locations, for example to affix a plurality of tethers (not shown) for use in interaction with software applications while a user is using exercise machine 100 (as described below, referring to FIG. 3).

[0044] Exercise machine 100 may further comprise a rigid handlebar 103 affixed or integrally-formed on one end of exercise machine 100, for a user to hold onto while facing forward during use. Handlebar 103 may further comprise a stand or mount 104 for a user's smart device such as (for example) a smartphone or tablet computer, so they may safely support and stow the device during use while keeping it readily accessible for interaction (for example, to configure or interact with a software application they are using, or to select different applications, or to control media playback during use, or other various uses). Handlebar 103 may be used to provide a stable handle for a user to hold onto during use for safety or stability, as well as providing a rigid point for the user to "push off" during use as needed, for example to begin using a moving treadmill surface (described below in FIG. 2). During use, a user may also face away from handlebar 103, using exercise machine 100 in the reverse without their view or range of motion being obscured or obstructed by handlebar 103 (for example, for use with a virtual reality game that requires a wide degree of movement from the user's hands for interaction).

[0045] As illustrated, the base 101 of exercise machine 100 may be formed with a mild, symmetrical curvature, to better approximate the natural range of movement of a user's body during use. Common exercise machines such as treadmills generally employ a flat surface, which can be uncomfortably during prolonged or vigorous use, and may cause complications with multi-directional movement or interaction while a user's view is obscured, as with a headset (described below in FIG. 3). By incorporating a gradual curvature, a user's movements may feel more natural and require less reorientation or accommodation to become fluid and proficient, and stress to the body may be reduced.

[0046] FIG. 3 is a diagram illustrating an exemplary system for a virtual reality or mixed reality enhanced exercise machine 100 with wireless communication for smart device control and interactive software applications using a smart device, illustrating the use of a plurality of connected smart devices and tethers, and showing interaction via the user's body as a control stick. According to the embodiment, a user 301 may be standing, walking, or running on a variable-resistance exercise machine 100 with wireless communication for smart device control and virtual reality applications with a stable base 101 and two separate moveable surfaces 203a, 203b for separate movement of the user's legs. Exercise machine 100 may have fixed handlebars with affixed or integrally-formed controllers 305a, 305b

for use as connected smart devices for interaction, and support rails **201a**, **201b** for a user to hold onto or affix tethers for safety or interaction when needed. User **401** may interact with software applications using a variety of means, including manual interaction via controller devices **305a**, **305b** that may be held in the hand for example to use as motion-input control devices or (as illustrated) may be affixed or integrally-formed into exercise machine **100**. This may provide a user with traditional means of interacting with software applications while using exercise machine **100**. Additionally, a user's body position or movement may be tracked and used as input, for example via a plurality of tethers **304a-n** affixed to handlebars **201a**, **201b** and a belt, harness or saddle **303** worn by user **301**, or using a headset device **302** that may track the position or movement of a user's head as well as provide video (and optionally audio) output to the user, such as a virtual reality headset that displays images while blocking the user's view of the outside world, or an augmented reality or mixed reality headset that combines presented information with the user's view using transparent or semitransparent displays (for example, using transparent OLED displays, hologram displays, projected displays, or other various forms of overlaying a display within a user's normal field of vision without obstructing the user's view). Body tracking may be used to recognize additional input data from user **301** (in addition to manual input via controllers **305a**, **305b**), by tracking the position and movement of user **301** during use. For example, motion tracking within a headset device **302** may be used to recognize a variety of translational **310** or rotational **320** movement of user's **301** head, such as leaning to the side, or looking over the shoulder. Tethers **304a-n** may recognize a variety of movement of user's **301** torso, such as leaning, crouching, sidestepping, or other body movement. This body tracking may then be utilized either as feedback to rehab programs (for example, to track a user's posture for physical therapy coaching or exercises such as holding yoga poses) or input similar to a control stick or joystick in manual controller arrangements, for example by interpreting the user's entire body as the "stick" and processing their body movements as if they were stick movements done manually (such as to control in-game character posture or movement, or to direct movement in certain applications such as vehicle simulations that may turn or accelerate in response to stick movements).

[0047] For example, a user **301** on exercise machine **100** may be playing a virtual reality skiing game or rehab program wherein they are given audio and video output via a headset **302** to immerse them in a virtual ski resort. When user **301** is not skiing, they may be able to use manual controls **305a**, **305b** for such operations as selecting from an on-screen menu, or typing text input such as to input their name or to chat with other players using text. When they begin skiing within the game, user **301** may be instructed in proper ski posture or technique, and may then use their body to control various aspects of their virtual skiing, such as leaning to the side **320** to alter their course and avoid trees or other skiers, or jumping **310** to clear rocks or gaps. Movement of their head may be detected by a headset **302** and used to control their view independently of their body as it is tracked by tethers **304a-n**, allowing user **301** to look around freely without interfering with their other controls. In this manner, the user's entire body may serve as an input control device for the game, allowing and encouraging them

to use natural body movements to control their gameplay in an immersive manner while still retaining the option to use more familiar manual control means as needed. Alternatively, specific body functions such as hip twisting are used as user feedback for rehabilitating programs, including rehab games.

[0048] FIG. 12 is a diagram illustrating an exemplary system **1200** for a virtual reality or mixed reality enhanced exercise machine **100**, illustrating the use of a plurality of optical sensors to detect body movement of a user during use of an exercise machine. As above (with reference to FIG. 3), a user **301** may be standing, walking or running, sitting, or otherwise physically active during use of an exercise machine **100**. During use, the user's position, posture, movement, cadence, technique, or any other movement or position-related information may be detected, observed, or measured using a plurality of body movement sensors such as (for example, including but not limited to) tethers **304a-n** that may optionally be affixed to handlebars **201a-b** or other features of an exercise machine **100**, hardware sensors integrated into controllers **305a-b** or a headset **302** the user may be using during exercise for virtual reality or mixed reality applications, or using a plurality of optical sensors **1201a-n** that may be affixed to an exercise machine **100** or adjacent equipment, or that may be affixed to or positioned within an environment around exercise machine **100** to observe the user **301** during use. Optical sensors **1201a-n** may be used in a variety of configurations or arrangements, such as using a single wide-angle sensor positioned to observe a user's movement or posture from a particular angle (which may be useful for coaching or physical therapy applications), or using more than one sensor placed about a user to observe their movement in three-dimensional space. A variety of hardware may be utilized in optical sensors **1201a-n**, for example including (but not limited to) an infrared or other optical camera that may directly observe the user's movement, a structured-light emitter that projects a structured-light grid **1202** or other arrangement onto the user, exercise machine, or environment (and corresponding scanner or receiver that may observe the user's movement through detected changes in the structured-light projection), or a light-field sensor that detects or measures depth to observe a user's movement in three-dimensions. It should also be appreciated that various combination of optical sensors **1201a-n** may be utilized to achieve a desired effect, for example using both structured light and a light-field sensor to observe a user's movement in precise detail in three dimensions. Additionally, some or all optical sensors **1201a-n** utilized in some arrangements may be integrated into a user's headset **302** or an exercise machine **100** to provide "inside-out" tracking where tracking sensors are associated with the user rather than the environment, or they may be external devices as illustrated that may be introduced to enhance an existing exercise machine or environment.

[0049] Utilizing an exercise machine **100** in this manner allows for a variety of novel forms of user interaction within virtual reality or mixed reality applications. For example, a user's body movement during exercise may be tracked in three dimensions and along or around various axes to record movement with six degrees of freedom (6DOF) comprising both translation along, and rotation about, each of three spatial axes. This may be used with torso tracking as described above (referring to FIGS. 3-7) to produce a 6DOF "torso joystick" virtual device that directs movement or

other inputs within a software application. This may be used in a number of ways, for example including but not limited to aiding exercise through interactive coaching (either with a human coach or using software to simulate a coach by providing feedback to detected user movements), providing physical therapy, interacting with games or other applications during exercise, or using exercise combined with software interaction for an immersive virtual reality or mixed reality experience. For example, a user may control movement or expression of a virtual avatar or other user representation within a software application, such as using their own body movements to direct movement of a virtual character. Physical therapy or fitness coaching may utilize detected movements to assist a user with improving their abilities or technique, or to measure progress. Social interaction applications may utilize body movements during exercise, for example a chat or voice call application may utilize body movement as a form of nonverbal expression similar to emoji or other icons. Safety may also be enhanced by controlling the operation of software in response to detected user movements, for example displaying caution information or pausing an application if a user is detected to move outside a configured safety parameter (such as stepping off a running treadmill, for example).

[0050] FIG. 8 is a block diagram of an exemplary system architecture **800** for natural body interaction for mixed or virtual reality applications, according to a preferred embodiment of the invention. According to the embodiment, a composition server **801** comprising programming instructions stored in a memory **11** and operating on a processor **12** of a computing device **10** (as described below, with reference to FIG. 13), may be configured to receive a plurality of input data from various connected devices. Such input devices may include (but are not limited to) a variety of hardware controller devices **804** (such as a gaming controller [such as GOJI PLAY™ controllers], motion tracking controller, or traditional computer input devices such as a keyboard or mouse), a headset device **803** such as an augmented reality or mixed or virtual reality headset (for example, OCULUS RIFT™, HTC VIVE™, SAMSUNG GEAR VR™, MICROSOFT MIXED REALITY™, or other headset devices), a variety of fitness devices **805** (for example, fitness tracking wearable devices such as FIT-BIT™, MICROSOFT BAND™, APPLE WATCH™, or other wearable devices), or a variety of body input **802** tracking devices or arrangements, such as using a plurality of tethers attached to the environment and a harness worn by a user, configured to track movement and position of the user's body.

[0051] Various input devices may be connected to composition server **801** interchangeably as desired for a particular arrangement or use case, for example a user may wish to use a controller **804** in each hand and a headset **803**, but omit the use of fitness devices **805** altogether. During operation, composition server **801** may identify connected devices and load any stored configuration corresponding to a particular device or device type, for example using preconfigured parameters for use as a default configuration for a new controller, or using historical configuration for a headset based on previous configuration or use. For example, a user may be prompted (or may volunteer) to provide configuration data for a particular device, such as by selecting from a list of options (for example, "choose which type of device this is", or "where are you wearing/holding this device", or

other multiple-choice type selection), or composition server **801** may employ machine learning to automatically determine or update device configuration as needed. For example, during use, input values may be received that are determined to be "out of bounds", for example an erroneous sensor reading that might indicate that a user has dramatically shifted position in a way that should be impossible (for example, an erroneous reading that appears to indicate the user has moved across the room and back again within a fraction of a second, or has fallen through the floor, or other data anomalies). These data values may be discarded, and configuration updated to reduce the frequency of such errors in the future, increasing the reliability of input data through use.

[0052] Composition server **801** may receive a wide variety of input data from various connected devices, and by comparing against configuration data may discard undesirable or erroneous readings as well as analyze received input data to determine more complex or fine-grained measurements. For example, combining input from motion-sensing controllers **804** with a motion-sensing headset **803** may reveal information about how a user is moving their arms relative to their head or face, such as covering their face to shield against a bright light or an attack (within a game, for example), which might otherwise be impossible to determine with any reliability using only the controllers themselves (as it may be observed that a user is raising their hands easily enough, but there is no reference for the position or movement of their head). These derived input values may then be combined into a single composite input data stream for use by various software applications, such as augmented reality or mixed or virtual reality productivity applications (for example, applications that assist a user in performing manual tasks by presenting virtual information overlays onto their field of vision, or by playing audio directions to instruct them while observing their behavior through input devices, or other such applications), or mixed or virtual reality applications or games, such as simulation games that translate a user's movement or position into in-game interaction, for example by moving a user's in-game character or avatar based on their physical movements as received from input devices. In some arrangements, composition server **801** may operate such software applications in a standalone manner, functioning as a computer or gaming console as needed. In other arrangements, composition server **801** may provide the composite data for use by an external computer **810**, such as a connected gaming console, mixed or virtual reality device, personal computer, or a server operating via a network in the cloud (such as for online gaming arrangements, for example). In this manner, the composite data functions of the embodiment may be utilized with existing hardware if desired, or may be provided in a standalone package such as for demonstrations or public use, or for convenient setup using a single device to provide the full interaction experience (in a manner similar to a household gaming console, wherein all the functions of computer components may be prepackaged and setup to minimize difficulty for a new user).

[0053] It should be appreciated that while reference is made to virtual reality applications, a wide variety of use cases may be possible according to the embodiment. For example, torso tracking may be used for fitness and health applications, to monitor a user's posture or gait while walking, without the use of additional virtual reality equip-

ment or software. In some arrangements, some or all interaction between a user and a software application may be nonvisual, and in some arrangements no display device may be present. In such an arrangement, a user may interact with software entirely using feedback and movement of a worn harness **420** or tethers **304a-n**, using resistance or software-guided actuation of tethers **304a-n** (as described below, with reference to FIGS. 4-7) or other elements. In other arrangements, various combinations of display devices and other electronic devices may be used for a mixed-reality setup, for example where a user's movement and interaction may be used by software to incorporate elements of the physical world into a digital representation of the user or environment. For example, a user may interact with games or fitness applications, participate in social media such as chat, calls, online discussion boards, social network postings, or other social content, or they may use body tracking to navigate user interface elements of software such as a web browser or media player. Software used in this manner may not need to be specially-configured to utilize body tracking, for example to navigate a web browser a user's body movements or reactions to feedback may be processed by a composition server **801** and mapped to generic inputs such as keystrokes or mouse clicks, for use in any standard software application without the need for special configuration.

[0054] It should be further appreciated that while reference is made to a treadmill-type exercise machine **100**, such an exercise machine is exemplary and any of a number of exercise machines may be utilized according to the aspects disclosed herein, for example including (but not limited to) a treadmill, a stationary bicycle, an elliptical machine, a rowing machine, or even non-electronic exercise equipment such as a pull-up bar or weight machine. Traditional exercise equipment may be outfitted with additional components to facilitate virtual reality or mixed reality interaction according to the aspects disclosed herein, for example by affixing a plurality of tethers **304a-n** to a weight machine so that a user's movement during exercise may be used as interaction as described below (with reference to FIGS. 3-7).

Detailed Description of Exemplary Embodiments

[0055] FIG. 2 is a top-down view of a variable-resistance exercise machine **100** with wireless communication for smart device control and interactive software applications, according to a preferred embodiment of the invention. According to the embodiment, exercise machine **100** may comprise a stable base **101** to provide a platform for a user to safely stand or move about upon. Exercise machine **100** may further comprise right **201a** and left **201b** hand rails for a user to brace against or grip during use, to provide a stable support for safety as well as a mounting point for external devices such as a plurality of tethers, as described below with reference to FIG. 3. A plurality of steps **202a-n** may be used to provide a user with a safe and easy means to approach or dismount exercise machine **100**, as well as a nonmoving "staging area" where a user may stand while they configure operation or wait for exercise machine **100** to start operation. Unlike traditional treadmill machines common in the art, exercise machine **100** may be made with greater width to accommodate a wider range of free movement of a user's entire body (whereas traditional treadmills are designed to best accommodate only a jogging or running posture, with minimal lateral motion), and a plurality of separate moving surfaces **203a-b** may be utilized to provide

multiple separate surfaces that may move and be controlled independently of one another during use. For example, a user may move each of their legs independently without resistance applied, with separate moving surfaces **203a-b** moving freely underfoot as a user applies pressure during their movement. This may provide the illusion of movement to a user while in reality they remain stationary with respect to their surroundings. Another use may be multiple separate moving surfaces **203a-b**, with separate speeds of movement or degrees of resistance, so that as a user moves about during use they may experience physical feedback in the form of changing speed or resistance, indicating where they are standing or in what direction they are moving (for example, to orient a user wearing a virtual reality headset, as described below with reference to FIG. 3). Moving surfaces **203a-b** may be formed with a texture **204** to increase traction, which may improve user safety and stability during use as well as improve the operation of moving surfaces **203a-b** for use in multidirectional movement (as the user's foot is less likely to slide across a surface rather than taking purchase and applying directional pressure to produce movement). Use of multiple, multidirectional moving surfaces **203a-b** may also be used in various therapeutic or rehabilitation roles, for example to aid a user in developing balance or range of motion. For example, a user who is recovering from an injury or surgery (such as a joint repair or replacement surgery) may require regular physical therapy during recovery. Use of multidirectional moving surfaces **203a-b** along with appropriate guidance from a rehabilitation specialist or physical therapist (or optionally a virtual or remote coach using a software application) may make regular therapy more convenient and accessible to the user, rather than requiring in-home care or regular visits to a clinic. For example, by enabling a therapist or coach to manually vary the movement and resistance of the moving surfaces **203a-b**, they can examine a user's ability to overcome resistance to different movements such as at odd angles or across varying range of motion, to examine the user's physical health or ability. By further varying the resistance it becomes possible to assist the user with rehabilitation by providing targeted resistance training to specific movements, positions, or muscle groups to assist in recovery and development of the user's abilities.

[0056] Exercise machine **100** may be designed without a control interface commonly utilized by exercise machines in the art, instead being configured with any of a variety of wireless network interfaces such as Wi-Fi or BLUETOOTH™ for connection to a user's smart device, such as a smartphone or tablet computer. When connected, a user may use a software application on their device to configure or direct the operation of exercise machine **100**, for example by manually configuring a variety of operation settings such as speed or resistance, or by interacting with a software application that automatically directs the operation of exercise machine **100** without exposing the particular details of operation to a user. Additionally, communication may be bi-directional, with a smart device directing the operation of exercise machine **100** and with exercise machine **100** providing input to a smart device based at least in part on a user's activity or interaction. For example, a user may interact with a game on their smart device, which directs the operation of exercise machine **100** during play as a form of interaction with, and feedback to, the user. For example, in a racing game, exercise machine **100** may alter the resistance

of moving surfaces **203a-b** as a user's speed changes within the game. In another example, a user may be moving about on moving surfaces **203a-b** while playing a simulation or roleplaying game, and their movement may be provided to the connected smart device for use in controlling an in-game character's movement. Another example may be two-way interactive media control, wherein a user may select media such as music for listening on their smart device, and then while using exercise machine **100** their level of exertion (for example, the speed at which they run or jog) may be used to provide input to their smart device for controlling the playback of media. For example, if the user slows down music may be played slowly, distorting the audio unless the user increases their pace. In this manner, exercise machine **100** may be used interchangeably as a control and feedback device or both simultaneously, providing an immersive environment for a wide variety of software applications such as virtual reality, video games, fitness and health applications, or interactive media consumption.

[0057] FIG. 4 is a diagram of an exemplary hardware arrangement **400** for natural torso tracking and feedback for electronic interaction according to a preferred embodiment of the invention, illustrating the use of multiple tethers **410a-n** and a movable torso harness **420**. According to the embodiment, a plurality of tethers **410a-n** may be affixed or integrally-formed as part of a handle or railing **430**, such as handlebars found on exercise equipment such as a treadmill, elliptical trainer, stair-climbing machine, or the like. In alternate arrangements, specifically-designed equipment with integral tethers **410a-n** may be used, but it may be appreciated that a modular design with tethers **410a-n** that may be affixed and removed freely may be desirable for facilitating use with a variety of fitness equipment or structural elements of a building, according to a user's particular use case or circumstance. Tethers **410a-n** may then be affixed or integrally-formed to a torso harness **420**, as illustrated in the form of a belt, that may be worn by a user such that movement of their body affects tethers **410a-n** and applies stress to them in a variety of manners. It should be appreciated that while a belt design for a torso harness **420** is shown for clarity, a variety of physical arrangements may be used such as including (but not limited to) a vest, a series of harness-like straps similar to climbing or rappelling equipment, a backpack, straps designed to be worn on a user's body underneath or in place of clothing (for example, for use in medical settings for collecting precise data) or a plurality of specially-formed clips or attachment points that may be readily affixed to a user's clothing. Additionally, a torso harness **420** may be constructed with movable parts, for example having an inner belt **421** that permits a user some degree of motion within the harness **420** without restricting their movement. Movement of inner belt **421** (or other movable portions) may be measured in a variety of ways, such as using accelerometers, gyroscopes, or optical sensors, and this data may be used as interaction with software applications in addition to data collected from tethers **410a-n** as described below. In some embodiments, a saddle-like surface on which a user may sit may be used, with motion of the saddle-like surface measured as described generally herein.

[0058] As a user moves, his or her body naturally shifts position and orientation. These shifts may be detected and measured via tethers **410a-n**, for example by detecting patterns of tension or strain on tethers **410a-n** to indicate

body orientation, or by measuring small changes in strain on tethers **410a-n** to determine more precise movements such as body posture while a user is speaking, or specific characteristics of a user's stride or gait. Additionally, through varying the quantity and arrangement of tethers **410a-n**, more precise or specialized forms of movement may be detected and measured (such as, for example, using a specific arrangement of multiple tethers connected to a particular area of a user's body to detect extremely small movements for medical diagnosis or fitness coaching). This data may be used as interaction with software applications, such as for virtual reality applications as input for a user to control a character in a game. In such an arrangement, when a user moves, this movement may be translated to an in-game character or avatar to convey a more natural sense of interaction and presence. For example, in a multiplayer roleplaying game, this may be used to facilitate nonverbal communication and recognition between players, as their distinct mannerisms and gestures may be conveyed in the game through detection of natural torso position and movement. In fitness or health applications, this data may be used to track and monitor a user's posture or ergonomic qualities, or to assist in coaching them for specific fitness activities such as holding a pose for yoga, stretching, or proper running form during use with a treadmill. In medical applications, this data may be used to assist in diagnosing injuries or deficiencies that may require attention, such as by detecting anomalies in movement or physiological adaptations to an unrecognized injury (such as when a user subconsciously shifts their weight off an injured foot or knee, without consciously realizing an issue is present).

[0059] Through various arrangements of tethers **410a-n** and tether sensors (as described below, referring to FIGS. 5-7), it may be possible to enable a variety of immersive ways for a user to interact with software applications, as well as to receive haptic feedback from applications. For example, by detecting rotation, tension, stress, or angle of tethers a user may interact with applications such as virtual reality games or simulations, by using natural body movements and positioning such as leaning, jumping, crouching, kneeling, turning, or shifting their weight in various directions to trigger actions within a software application configured to accept torso tracking input. By applying haptic feedback of varying form and intensity (as is described in greater detail below, referring to FIG. 5), applications may provide physical indication to a user of software events, such as applying tension to resist movement, pulling or tugging on a tether to move or "jerk" a user in a direction, or varying feedback to multiple tethers such as tugging and releasing in varying order or sequence to simulate more complex effects such as (for example, in a gaming use case) explosions, riding in a vehicle, or walking through foliage.

[0060] FIG. 5 is a diagram illustrating a variety of alternate tether arrangements. According to various use cases and hardware arrangements, tethers **410a-n** may utilize a variety of purpose-driven designs as illustrated. For example, a "stretchable" tether **510** may be used to measure strain during a user's movement, as the tether **510** is stretched or compressed (for example, using piezoelectric materials and measuring electrical changes). Such an arrangement may be suitable for precise measurements, but may lack the mechanical strength or durability for gross movement detection or prolonged use. An alternate construction may utilize a non-deforming tether **520** such as a steel cable or similar

non-stretching material. Instead of measuring strain on the tether 520, instead tether 520 may be permitted a degree of movement within an enclosure 522 (for example, an attachment point on a torso harness 420 or handlebar 430), and the position or movement 521 of the tether 520 may be measured such as via optical sensors. In a third exemplary arrangement, a tether 530 may be wound about an axle or pulley 531, and may be let out when force is applied during a user's movement. Rotation of the pulley 531 may be measured, or alternately a tension device such as a coil spring may be utilized (not shown) and the tension or strain on that device may be measured as tether 530 is extended or retracted. In this manner, it may be appreciated that a variety of mechanical means may be used to facilitate tethers and attachments for use in detecting and measuring natural torso position and movement, and it should be appreciated that a variety of additional or alternate hardware arrangements may be utilized according to the embodiments disclosed herein.

[0061] Additionally, through the use of various hardware construction it becomes possible to utilize both "passive" tethers that merely measure movement or strain, as well as "active" tethers that may apply resistance or movement to provide haptic feedback to a user. For example, in an arrangement utilizing a coiled spring or pulley 531, the spring or pulley 531 may be wound to retract a tether and direct or impede a user's movement as desired. In this manner, various new forms of feedback-based interaction become possible, and in virtual reality use cases user engagement and immersion are increased through more natural physical feedback during their interaction.

[0062] By applying various forms and intensities of feedback using various tether arrangements, a variety of feedback types may be used to provide haptic output to a user in response to software events. For example, tension on a tether may be used to simulate restrained movement such as wading through water or dense foliage, walking up an inclined surface, magnetic or gravitational forces, or other forms of physical resistance or impedance that may be simulated through directional or non-directional tension. Tugging, retracting, or pulling on a tether may be used to simulate sudden forces such as recoil from gunfire, explosions, being grabbed or struck by a software entity such as an object or character, deploying a parachute, bungee jumping, sliding or falling, or other momentary forces or events that may be conveyed with a tugging or pulling sensation. By utilizing various patterns of haptic feedback, more complex events may be communicated to a user, such as riding on horseback or in a vehicle, standing on the deck of a ship at sea, turbulence in an aircraft, weather, or other virtual events that may be represented using haptic feedback. In this manner, virtual environments and events may be made more immersive and tangible for a user, both by enabling a user to interact using natural body movements and positioning, as well as by providing haptic feedback in a manner that feels natural and expected to the user. For example, if a user is controlling a character in a gaming application through a first-person viewpoint, it would seem natural that when their character is struck there would be a physical sensation corresponding to the event; however, this is not possible with traditional interaction devices, detracting from any sense of immersion or realism for the user. By providing this physical sensation alongside the virtual event, the experience becomes more engaging and users are encouraged to

interact more naturally as their actions results in natural and believable feedback, meeting their subconscious expectations and avoiding excessive "immersion-breaking" moments, which in turn reduces the likelihood of users adopting unusual behaviors or unhealthy posture as a result of adapting to limited interaction schema.

[0063] Haptic feedback may be provided to notify a user of non-gaming events, such as for desktop notifications for email or application updates, or to provide feedback on their posture for use in fitness or health coaching. For example, a user may be encouraged to maintain a particular stance, pose, or posture while working or for a set length of time (for example, for a yoga exercise application), and if their posture deviates from an acceptable range, feedback is provided to remind them to adjust their posture. This may be used in sports, fitness, health, or ergonomic applications that need not utilize other aspects of virtual reality and may operate as traditional software applications on nonspecialized computing hardware. For example, a user at their desk may use an ergonomic training application that monitors their body posture throughout the work day and provides haptic reminders to correct poor posture as it is detected, helping the user to maintain a healthy working posture to reduce fatigue or injuries due to poor posture (for example, repetitive-stress injuries that may be linked to poor posture while working at a computer).

[0064] FIG. 6 is a diagram of an additional exemplary hardware arrangement 600 for natural torso tracking and feedback for electronic interaction according to a preferred embodiment of the invention, illustrating the use of angle sensors 612, 621a-n to detect angled movement of a tether 620. According to one exemplary arrangement, a tether 610 may be affixed to or passed through a rotating joint such as a ball bearing 611 or similar, to permit free angular movement. During movement, the angular movement or deflection 612 of a protruding bar, rod, or tether segment 613 may be measured (for example, using optical, magnetic, or other sensors) to determine the corresponding angle of tether 610. In this manner, precise angle measurements may be collected without impeding range of motion or introducing unnecessary mechanical complexity.

[0065] In an alternate hardware arrangement, the use of angle sensors 621a-n enables tracking of a vertical angle of a tether 620, to detect and optionally measure vertical movement or orientation of a user's torso. When tether 620 contacts a sensor 621a-n, this may be registered and used to detect a general vertical movement (that is, whether the tether is angled up or down). For more precise measurements, the specific hardware construction of a sensor 621a-n may be varied, for example using a pressure-sensing switch to detect how much force is applied and use this measurement to determine the corresponding angle (as may be possible given a tether 620 of known construction). It should be appreciated that various combinations of hardware may be used to provide a desired method or degree of angle detection or measurement, for example using a conductive tether 620 and a capacitive sensor 621a-n to detect contact, or using a mechanical or rubber-dome switch (as are commonly used in keyboard construction) to detect physical contact without a conductive tether 620.

[0066] The use of angle detection or measurement may expand interaction possibilities to encompass more detailed and natural movements of a user's body. For example, if a user crouches, then all tethers 410a-n may detect a down-

ward angle simultaneously. Additionally, data precision or availability may be enhanced by combining input from multiple available sensors when possible (for example, utilizing adaptive software to collect data from any sensors that it detects, without requiring specific sensor types for operation), for example by combining data from tethers **410a-n** and hardware sensors such as an accelerometer or gyroscope, enabling multiple methods of achieving similar or varied types or precision levels of position or movement detection. Similarly, when a user jumps then all tethers may detect an upward angle simultaneously. However, if a user leans in one direction, it may be appreciated that not all tethers **410a-n** will detect the same angle. For example, tethers **410a-n** in the direction the user is leaning may detect a downward angle, while those on the opposite side would detect an upward angle (due to the orientation of the user's torso and thus a worn torso harness **420**). In this manner, more precise torso interaction may be facilitated through improved detection and recognition of orientation and movement. Additionally, it may be appreciated that sensors **621a-n** may be utilized for other angle measurements, such as to detect horizontal angle. For example, if a user is wearing a non-rotating torso harness **420**, when they twist their body a similar stress may be applied to all attached tethers **410a-n**. Without angle detection the precise nature of this movement will be vague, but with horizontal angle detection it becomes possible to recognize that all tethers **410a-n** are being strained in a similar direction (for example, in a clockwise pattern when viewed from above, as a user might view tethers **410a-n** during use), and therefore interpret the interaction as a twisting motion (rather than, for example, a user squatting or kneeling, which might apply a similar stress to the tethers **410a-n** but would have different angle measurements).

[0067] FIG. 7 is a diagram illustrating an exemplary hardware arrangement of an apparatus for natural torso tracking and feedback for electronic interaction according to a preferred embodiment of the invention, illustrating the use of multiple tethers **410a-n** and a movable torso harness **420** comprising a plurality of angle sensors **701a-n** positioned within the movable torso harness **420**. According to the embodiment, a plurality of tethers **410a-n** may be affixed or integrally-formed as part of a handle or railing **430**, such as handlebars found on exercise equipment such as a treadmill, elliptical trainer, stair-climbing machine, or the like. In alternate arrangements, specifically-designed equipment with affixed or integral tethers **410a-n** may be used, but it may be appreciated that a modular design with tethers **410a-n** that may be affixed and removed freely may be desirable for facilitating use with a variety of fitness equipment or structural elements of a building, according to a user's particular use case or circumstance as well as weight-holding strength of the tethers. Tethers **410a-n** may then be affixed or integrally-formed to angle sensors **701a-n** placed within or integrally-formed as a component of torso harness **420** (as illustrated in the form of a belt) that may be worn by a user such that movement of their body affects tethers **410a-n** and applies detectable or measurable stress to tethers **410a-n** and angular motion to angle sensors **701a-n**. In this manner, it may be appreciated that angle sensors **701a-n** may be utilized as integral or removable components of a torso harness **420**, as an alternative arrangement to utilizing angle sensors **701a-n** placed or formed within railings **430** or other equipment components connected to distal ends of tethers

410a-n (with respect to the user's torso). According to various embodiments, sensors may be placed optionally on a belt, vest, harness, or saddle-like surface or at attachment points on safety railings, or indeed both.

[0068] FIG. 9 is a block diagram of an exemplary system architecture **900** of an exercise machine **100** being connected over local connections to a smartphone or computing device **930**, an output device other than a phone **910**, and a server over a network **940**, according to a preferred aspect. An exercise machine **100** may connect over a network **920**, which may be the Internet, a local area connection, or some other network used for digital communication between devices, to a server **940**. Such connection may allow for two-way communication between a server **940** and an exercise machine **800**. An exercise machine **100** may also be connected over a network **920** to a smartphone or computing device **930**, or may be connected directly to a smartphone or computing device **930** either physically or wirelessly such as with Bluetooth connections. An exercise machine **100** also may be connected to an output device **910** which may display graphical output from software executed on an exercise machine **100**, including Mixed or virtual reality software, and this device may be different from a smartphone or computing device **930** or in some implementations may in fact be a smartphone or computing device **930**. A remote server **940** may contain a data store **941**, and a user verification component **942**, which may contain typical components in the art used for verifying a user's identity from a phone connection or device connection, such as device ID from a smartphone or computing device or logging in with a user's social media account.

[0069] FIG. 10 is a diagram of an exemplary hardware arrangement of a smart phone or computing device **1030** executing software **1010** and communicating over a network **1020**, according to a preferred aspect. In an exemplary smart phone or computing device **1030**, key components include a wireless network interface **1031**, which may allow connection to one or a variety of wireless networks including Wi-Fi and Bluetooth; a processor **1032**, which is capable of communicating with other physical hardware components in the computing device **1030** and running instructions and software as needed; system memory **1033**, which stores temporary instructions or data in volatile physical memory for recall by the system processor **1032** during software execution; and a display device **1034**, such as a Liquid Crystal Display (LCD) screen or similar, with which a user may visually comprehend what the computing device **1030** is doing and how to interact with it. It may or may not be a touch enabled display, and there may be more components in a computing device **1030**, beyond what are crucially necessary to operate such a device at all. Software **1010** operating on a processor **1033** may include a mixed or virtual reality application, a user verification system, or other software which may communicate with a network-enabled server **1040** and exercise machine **100** software for the purposes of enhanced mixed or virtual reality.

[0070] FIG. 11 is a block diagram of a method of mixed or virtual reality software operating to receive input through different sources, and send output to devices, according to a preferred aspect. Mixed or virtual reality software which may be run on a phone or computing device **1030** or another device, outputs data to a visual device for the purpose of graphically showing a user what they are doing in the software **1110**. Such display may be a phone display **1034**,

or a separate display device such as a screen built into an exercise machine **100** or connected some other way to the system, or both display devices. During software execution, user input may be received either through buttons **1130** on the exercise machine **100**, **1120**, or through input from a belt-like harness **420**, such as user orientation or movements. Such received data may be sent **1140** to either a mobile smart phone or computing device **1030**, or to a server **1040** over a network **1020**, or both, for processing, storage, or both. Data may be stored on a server with a data store device **1041** and may be processed for numerous uses including user verification with a user verification component **1042**. Data may be processed either by software running on an exercise machine **100**, a smart phone or computing device **1030**, or some other connected device which may be running mixed or virtual reality software, when input is received from a user using either buttons on an exercise machine **100**, a belt-like harness **420**, or both, and optionally using hardware features of an exercise machine **100** such as handlebars, pedals, or other features in mixed or virtual reality software for tasks such as representing movement in a simulation.

[0071] FIG. 17 is a block diagram of an exemplary virtual reality or mixed reality enhanced exercise machine, illustrating the use of a stationary bicycle **1700** with hand controls on the handles **1720**, and a belt-like harness attachment **420**. A stationary exercise bicycle device **1700**, which may be of any particular design including a reclining, sitting, or even unicycle-like design, possesses two pedals **1730** as is common for stationary exercise bicycles of all designs. On handlebars of a stationary exercise bicycle may exist buttons and controls **1720** for interacting with a virtual reality or mixed reality augmented piece of software, allowing a user to press buttons in addition to or instead of pedaling, to interact with the software. A belt-like harness attachment **420** is attached via a mechanical arm **1710** to a stationary exercise bicycle **1700**, which may monitor motion and movements from a user during the execution of virtual reality software. A mechanical arm **1710** may have an outer shell composed of any material, the composition of which is not claimed, but must have hinges **1711**, **1712**, **1713** which allow for dynamic movement in any position a user may find themselves in, and angular sensors inside of the arm at the hinge-points **1711**, **1712**, **1713** for measuring the movement in the joints and therefore movement of the user. A stationary bicycle device **1700** may also have a pressure sensor in a seat **1740**, the sensor itself being of no particularly novel design necessarily, to measure pressure from a user and placement of said pressure, to detect movements such as leaning or sitting lop-sided rather than sitting evenly on the seat.

[0072] FIG. 18 is a diagram of another exemplary virtual reality or mixed reality enhanced exercise machine, illustrating the use of a treadmill exercise machine **100**, **1800** a vest-type harness **1820** with a plurality of pistons **1811** to provide a hardware-based torso joystick with full-body tracking. According to this embodiment, a treadmill or other exercise machine **100**, **1800** may comprise a plurality of rigid side tails **102** for a user to grip for support as needed during use (for example, as a balance aid or to assist getting on the machine and setting up other equipment properly) as well as a rigid stand or mount **104** for a user's smartphone or other computing device, that may be used to operate a virtual reality or mixed reality software application. Exer-

cise machine **100**, **1800** may further comprise a jointed arm **1810** or similar assembly that may be integrally-formed or removably affixed to or installed upon exercise machine **100**, **1800**. Arm **1810** may utilize a plurality of pistons **1811** to provide for movement during use in order to follow the movement's of a user's body, as well as to provide tension or resistance to motion when appropriate (for example, to resist a user's movements or to provide feedback) and motion detection of a user's movement during use, according to various aspects described previously (referring to FIGS. 3-7, for example) by measuring movement of a piston **1811** or arm **1810** and optionally applying tension or resistance to piston **1811** to retard movement of arm **1810** and constrain user movement or simulate specific forms of physical feedback. For example, if a user is moving an avatar in a virtual reality software application, when the avatar encounters an obstacle such as another avatar, object, or part of the environment, resistance may be applied to piston **1811** to prevent the user from moving further, so that their avatar is effectively prevented from moving through the obstacle and thereby facilitating the immersive experience of a solid object in a virtual environment. Additional arms may be used for a user's limbs **1921** and may incorporate straps **1922** to be affix about a user's arm, wrist, or other body part, to incorporate more detailed movement tracking of a user's arms and/or legs rather than just torso-based tracking. A vest-type harness **1920** may be used in place of a belt **420**, to allow for more natural movement or to provide greater area upon which to affix additional arms **1821**, pistons **1811**, or any of a variety of sensors, for example such as accelerometers **1822** or gyroscopes **1823** for detecting body orientation (not all optional sensors are shown for the sake of clarity). For example, a vest **1820** may have integrated feedback actuators **1812** for use in first-person software applications to simulate impacts or recoil, or it may incorporate heating or cooling elements to simulate different virtual environments while worn. Additionally, vest **1820** may incorporate electrical connectors **1824** for various peripheral devices such as controllers **305a-b** or a headset **302**, reducing the risk of tangles or injury by keeping cables short and close to the user so they cannot cause issues during movement or exercise.

[0073] FIG. 19 is a diagram of another exemplary virtual reality or mixed reality enhanced exercise machine, illustrating the use of a stationary bicycle This present application is a continuation-in-part of Ser. No. 16/176,511, titled "VIRTUAL REALITY AND MIXED REALITY ENHANCED EXERCISE MACHINE", and filed on Oct. 31, 2018, which with a vest-type harness **1820** with a plurality of strain sensors **1911** and tethers **1912**, according to an aspect of the invention. According to this embodiment, rather than a jointed arm **1810** and pistons **1811**, a solid flexible arm **1910** may be used to detect user movement while positioned on a seat **1902** to use exercise machine **100**, for example while the user is seated to use pedals **1901** on a stationary bike or elliptical training machine. Through a plurality of strain gauges **1911** that detect the flexion or extension of the solid arm. Tethers **1912** may be used for either movement tracking or providing feedback to a user, or both, and may optionally be connected or routed through joints or interconnects **1913** to allow for a greater variety of attachment options as well more precise feedback (for example, by enabling multiple angles from which a tether **1912** may apply force, to precisely simulate different

effects). Additional arms may be used for a user's limbs **1921** and may incorporate straps **1922** to be affixed about a user's arm, wrist, or other body part, to incorporate more detailed movement tracking of a user's arms and/or legs rather than just torso-based tracking. Additional arms **1921** may also incorporate additional tethers **1912** and strain sensors **1911** to track movement and apply feedback to specific body parts during use, further increasing precision and user immersion. A vest-type harness **1820** may be used in place of a belt **420**, to allow for more natural movement or to provide greater area upon which to affix additional arms **1921**, tether **1912**, or any of a variety of sensors, for example such as accelerometers or gyroscopes for detecting body orientation (not all optional sensors are shown for the sake of clarity). For example, a vest **1820** may have integrated feedback actuators for use in first-person software applications to simulate impacts or recoil, or it may incorporate heating or cooling elements to simulate different virtual environments while worn. Additionally, vest **1820** may incorporate electrical connectors **1914** for various peripheral devices such as controllers **305a-b** or a headset **302**, reducing the risk of tangles or injury by keeping cables short and close to the user so they cannot cause issues during movement or exercise.

[0074] FIG. 20 is a flow diagram illustrating an exemplary method **2000** for operating a virtual and mixed-reality enhanced exercise machine, according to one aspect. According to the aspect, a user may wear **2001** a torso harness such as a belt **420** or vest **1820** harness, while they engage in the use **2002** of an exercise machine **100**. While using the exercise machine **100**, the user's movements may be detected and measured **2003** through the use of a plurality of body movement sensors such as (for example, including but not limited to) strain sensors **1911**, tethers **410a-c**, **1912**, pistons **1811**, or optical sensors **1201a-n**. These measured user movements may then be mapped by a composition server **801** to correspond to a plurality of movement inputs of a virtual joystick device **2004**. These virtual joystick inputs may then be transmitted **2005** to a software application, for example a virtual reality or mixed reality application operating on a user device such as (for example, including but not limited to) a smartphone **930**, personal computing device, or headset **302**. Composition server **801** may then receive feedback from the software application **2006**, and may direct the operation of a plurality of feedback devices such as tethers **410a-c**, **1912** or pistons **1811** to resist or direct the user's movement **2007** to provide physical feedback to the user based on the received software feedback.

[0075] FIG. 21 is a system diagram of a key components in the analysis of a user's range of motion and balance training, according to a preferred embodiment. A datastore containing statistical data **2110** on a user's age category, gender, and other demographic data, as well as a datastore containing balancing algorithms **2120**, are connected to a collection of components integrated into an exercise system **2130**, including a plurality of sensors **2131**, a movement profile generator **2132**, a balance trainer **2133**, and a tuner **2134**. A plurality of sensors **2131** may be connected to varying parts of an exercise system, tethered to a user, or otherwise connected to or able to sense a user during exercise, and may inform a movement profile generator **2132** of the performance of a user's exercise during such exercise. A movement profile generator **2132** may use data

from a datastore containing statistical data on a user **2110** to generate movement profile of how a user performs and moves during exercise, in comparison with how they may be expected to move, and pass this data on to a balance trainer **2133** which is further connected to a datastore containing balance algorithms **2120**. A balance trainer **2133** accesses and utilizes balance algorithms **2120** in conjunction with assembled movement profile data **2132** and determines if a user is in need of correcting their form or balance during exercise. A tuner **2134** is connected to a datastore containing user profile data **2150** and also connected to a balance tuner **2133**, enabling a user's individual preferences or specifications, or exercise needs, to inform adjustments for a balance trainer **2133**, for example if a user would initially be detected as stumbling by a balance trainer **2133** but the user were to specify that they are not falling, and continue to exercise in this fashion for whatever reason (such as physical limitations), a tuner **2134** may adjust the balance trainer **2133** in this instance. Such information is stored in a user's profile data **2150**. A display **2140** is connected to core components **2130** and may display the warnings generated by a balance trainer **2133** or offer a user the opportunity to offer adjustments or physical information to a tuner **2134** for adjusting a balance trainer **2133**.

[0076] FIG. 22 is a system diagram of a user moving during exercise, in a form analogous to an inverted pendulum, according to a preferred aspect. A user **2210** may be wearing a sensor **2131**, either on their torso, leg, or some other part of their body, and move their body over an angle from vertical position **2220**. Angular momentum **2230** may be represented by θ' **2230**, a user's angle deviation from vertical being represented by θ **2220**, the gravitational constant of Earth being represented by g **2240, and the approximate height of a user's body-part acting similar to the bar of an inverted pendulum being represented by L **2250**. Using these symbols, an equation of the form $\theta'' = (g/L)\sin \theta$ may be used in conjunction with a sensor **2131** which may contain an accelerometer, gyroscope, or both, in order to characterize the angle θ **2220** and angular acceleration θ'' **2230** of a user **2210** as they perform an exercise. It is therefore possible to analyze and characterize a user's motions that may lead to a stumble or fall.**

[0077] FIG. 23 is a system diagram of a sensor measuring the range of motion of a user during a specific exercise, according to a preferred aspect. A user performing an exercise with their leg is shown, with a sensor **2131** and angular movement **2310**. A sensor **2131** may be used to characterize the angle of the user's motion, or be attached as an ankle weight for a more specific implementation (but by no means the only implementation of this process of using a sensor to measure an individual user's body parts during exercise), to achieve more information about user form in addition to or instead of using an inverted pendulum **2220** with a sensor **2131** inside, according to a preferred aspect.

[0078] FIG. 24 is a method diagram illustrating behavior and performance of key components for range of motion analysis and balance training, according to a preferred aspect. A user's movements may first be detected on or with an exercise machine, using a plurality of sensors **2131**, **2410**. Given a user's movements **2410**, statistical data on a user's demographics may be gathered **2420** using a datastore containing such information **2110**, to compare a user's movements with expected or anticipated norms based on acquired or default statistical data. A user's profile data **2150**

may then be accessed **2430**, and using a user's profile data **2150** which may contain individual preferences or information beyond statistical norms **2110** or sensor-acquired exercise data **2131**, analyses of a user's range of motion may occur **2440**. Such analyses may include examining differences between a user's expected motion during an exercise, with their actual motion, measuring individual, anomalous movements during a user's exercise (such as a single motion that does not match with the rest of the user's movements), and other techniques to analyze anomalies in a user's displayed exercise ability. A user's profile is also generated from these analyses **2440**, allowing a history of a user's exercise performance to be recorded for future analysis and for comparison with future observed exercise patterns and performance. A user's profile and exercise performance, along with any other notes, may be displayed **2450** with a graphical or textual display **2140**, allowing a user to see for themselves their performance and deficiencies as determined by the system. A further step may be to detect if a user is detected to be likely to fall or stumble **2460**, such as if a leg movement is not proper for a running motion on a treadmill, and display or sound a warning to a user **2470** using a display **2140** or any other method that may be available to the exercise device for warning a user of possible injury or failure. These warnings may further be recorded in a user profile **2150** for access by a tuner **2134** and balance trainer **2133** to help the user be aware of patterns of exercise performance that may lead to similar incidents in the future, before they happen, thereby helping to ensure safety of physically at-risk exercise machine users.

Hardware Architecture

[0079] Generally, the techniques disclosed herein may be implemented on hardware or a combination of software and hardware. For example, they may be implemented in an operating system kernel, in a separate user process, in a library package bound into network applications, on a specially constructed machine, on an application-specific integrated circuit (ASIC), or on a network interface card.

[0080] Software/hardware hybrid implementations of at least some of the embodiments disclosed herein may be implemented on a programmable network-resident machine (which should be understood to include intermittently connected network-aware machines) selectively activated or reconfigured by a computer program stored in memory. Such network devices may have multiple network interfaces that may be configured or designed to utilize different types of network communication protocols. A general architecture for some of these machines may be described herein in order to illustrate one or more exemplary means by which a given unit of functionality may be implemented. According to specific embodiments, at least some of the features or functionalities of the various embodiments disclosed herein may be implemented on one or more general-purpose computers associated with one or more networks, such as for example an end-user computer system, a client computer, a network server or other server system, a mobile computing device (e.g., tablet computing device, mobile phone, smartphone, laptop, or other appropriate computing device), a consumer electronic device, a music player, or any other suitable electronic device, router, switch, or other suitable device, or any combination thereof. In at least some embodiments, at least some of the features or functionalities of the various embodiments disclosed herein may be implemented

in one or more virtualized computing environments (e.g., network computing clouds, virtual machines hosted on one or more physical computing machines, or other appropriate virtual environments).

[0081] Referring now to FIG. 13, there is shown a block diagram depicting an exemplary computing device **10** suitable for implementing at least a portion of the features or functionalities disclosed herein. Computing device **10** may be, for example, any one of the computing machines listed in the previous paragraph, or indeed any other electronic device capable of executing software- or hardware-based instructions according to one or more programs stored in memory. Computing device **10** may be configured to communicate with a plurality of other computing devices, such as clients or servers, over communications networks such as a wide area network, a metropolitan area network, a local area network, a wireless network, the Internet, or any other network, using known protocols for such communication, whether wireless or wired.

[0082] In one embodiment, computing device **10** includes one or more central processing units (CPU) **12**, one or more interfaces **15**, and one or more busses **14** (such as a peripheral component interconnect (PCI) bus). When acting under the control of appropriate software or firmware, CPU **12** may be responsible for implementing specific functions associated with the functions of a specifically configured computing device or machine. For example, in at least one embodiment, a computing device **10** may be configured or designed to function as a server system utilizing CPU **12**, local memory **11** and/or remote memory **16**, and interface(s) **15**. In at least one embodiment, CPU **12** may be caused to perform one or more of the different types of functions and/or operations under the control of software modules or components, which for example, may include an operating system and any appropriate applications software, drivers, and the like.

[0083] CPU **12** may include one or more processors **13** such as, for example, a processor from one of the Intel, ARM, Qualcomm, and AMD families of microprocessors. In some embodiments, processors **13** may include specially designed hardware such as application-specific integrated circuits (ASICs), electrically erasable programmable read-only memories (EEPROMs), field-programmable gate arrays (FPGAs), and so forth, for controlling operations of computing device **10**. In a specific embodiment, a local memory **11** (such as non-volatile random access memory (RAM) and/or read-only memory (ROM), including for example one or more levels of cached memory) may also form part of CPU **12**. However, there are many different ways in which memory may be coupled to system **10**. Memory **11** may be used for a variety of purposes such as, for example, caching and/or storing data, programming instructions, and the like. It should be further appreciated that CPU **12** may be one of a variety of system-on-a-chip (SOC) type hardware that may include additional hardware such as memory or graphics processing chips, such as a QUALCOMM SNAPDRAGON™ or SAMSUNG EXYNOS™ CPU as are becoming increasingly common in the art, such as for use in mobile devices or integrated devices.

[0084] As used herein, the term "processor" is not limited merely to those integrated circuits referred to in the art as a processor, a mobile processor, or a microprocessor, but broadly refers to a microcontroller, a microcomputer, a

programmable logic controller, an application-specific integrated circuit, and any other programmable circuit.

[0085] In one embodiment, interfaces **15** are provided as network interface cards (NICs). Generally, NICs control the sending and receiving of data packets over a computer network; other types of interfaces **15** may for example support other peripherals used with computing device **10**. Among the interfaces that may be provided are Ethernet interfaces, frame relay interfaces, cable interfaces, DSL interfaces, token ring interfaces, graphics interfaces, and the like. In addition, various types of interfaces may be provided such as, for example, universal serial bus (USB), Serial, Ethernet, FIREWIRE™, THUNDERBOLT™, PCI, parallel, radio frequency (RF), BLUETOOTH™, near-field communications (e.g., using near-field magnetics), 802.11 (WiFi), frame relay, TCP/IP, ISDN, fast Ethernet interfaces, Gigabit Ethernet interfaces, Serial ATA (SATA) or external SATA (ESATA) interfaces, high-definition multimedia interface (HDMI), digital visual interface (DVI), analog or digital audio interfaces, asynchronous transfer mode (ATM) interfaces, high-speed serial interface (HSSI) interfaces, Point of Sale (POS) interfaces, fiber data distributed interfaces (FDDIs), and the like. Generally, such interfaces **15** may include physical ports appropriate for communication with appropriate media. In some cases, they may also include an independent processor (such as a dedicated audio or video processor, as is common in the art for high-fidelity AN hardware interfaces) and, in some instances, volatile and/or non-volatile memory (e.g., RAM).

[0086] Although the system shown in FIG. **13** illustrates one specific architecture for a computing device **10** for implementing one or more of the inventions described herein, it is by no means the only device architecture on which at least a portion of the features and techniques described herein may be implemented. For example, architectures having one or any number of processors **13** may be used, and such processors **13** may be present in a single device or distributed among any number of devices. In one embodiment, a single processor **13** handles communications as well as routing computations, while in other embodiments a separate dedicated communications processor may be provided. In various embodiments, different types of features or functionalities may be implemented in a system according to the invention that includes a client device (such as a tablet device or smartphone running client software) and server systems (such as a server system described in more detail below).

[0087] Regardless of network device configuration, the system of the present invention may employ one or more memories or memory modules (such as, for example, remote memory block **16** and local memory **11**) configured to store data, program instructions for the general-purpose network operations, or other information relating to the functionality of the embodiments described herein (or any combinations of the above). Program instructions may control execution of or comprise an operating system and/or one or more applications, for example. Memory **16** or memories **11**, **16** may also be configured to store data structures, configuration data, encryption data, historical system operations information, or any other specific or generic non-program information described herein.

[0088] Because such information and program instructions may be employed to implement one or more systems or methods described herein, at least some network device

embodiments may include nontransitory machine-readable storage media, which, for example, may be configured or designed to store program instructions, state information, and the like for performing various operations described herein. Examples of such nontransitory machine-readable storage media include, but are not limited to, magnetic media such as hard disks, floppy disks, and magnetic tape; optical media such as CD-ROM disks; magneto-optical media such as optical disks, and hardware devices that are specially configured to store and perform program instructions, such as read-only memory devices (ROM), flash memory (as is common in mobile devices and integrated systems), solid state drives (SSD) and “hybrid SSD” storage drives that may combine physical components of solid state and hard disk drives in a single hardware device (as are becoming increasingly common in the art with regard to personal computers), memristor memory, random access memory (RAM), and the like. It should be appreciated that such storage means may be integral and non-removable (such as RAM hardware modules that may be soldered onto a motherboard or otherwise integrated into an electronic device), or they may be removable such as swappable flash memory modules (such as “thumb drives” or other removable media designed for rapidly exchanging physical storage devices), “hot-swappable” hard disk drives or solid state drives, removable optical storage discs, or other such removable media, and that such integral and removable storage media may be utilized interchangeably. Examples of program instructions include both object code, such as may be produced by a compiler, machine code, such as may be produced by an assembler or a linker, byte code, such as may be generated by for example a JAVA™ compiler and may be executed using a Java virtual machine or equivalent, or files containing higher level code that may be executed by the computer using an interpreter (for example, scripts written in Python, Perl, Ruby, Groovy, or any other scripting language).

[0089] In some embodiments, systems according to the present invention may be implemented on a standalone computing system. Referring now to FIG. **14**, there is shown a block diagram depicting a typical exemplary architecture of one or more embodiments or components thereof on a standalone computing system. Computing device **20** includes processors **21** that may run software that carry out one or more functions or applications of embodiments of the invention, such as for example a client application **24**. Processors **21** may carry out computing instructions under control of an operating system **22** such as, for example, a version of MICROSOFT WINDOWS™ operating system, APPLE MACOS™ or iOS™ operating systems, some variety of the Linux operating system, ANDROID™ operating system, or the like. In many cases, one or more shared services **23** may be operable in system **20**, and may be useful for providing common services to client applications **24**. Services **23** may for example be WINDOWS™ services, user-space common services in a Linux environment, or any other type of common service architecture used with operating system **21**. Input devices **28** may be of any type suitable for receiving user input, including for example a keyboard, touchscreen, microphone (for example, for voice input), mouse, touchpad, trackball, or any combination thereof. Output devices **27** may be of any type suitable for providing output to one or more users, whether remote or local to system **20**, and may include for example one or more

screens for visual output, speakers, printers, or any combination thereof. Memory 25 may be random-access memory having any structure and architecture known in the art, for use by processors 21, for example to run software. Storage devices 26 may be any magnetic, optical, mechanical, memristor, or electrical storage device for storage of data in digital form (such as those described above, referring to FIG. 13). Examples of storage devices 26 include flash memory, magnetic hard drive, CD-ROM, and/or the like.

[0090] In some embodiments, systems of the present invention may be implemented on a distributed computing network, such as one having any number of clients and/or servers. Referring now to FIG. 15, there is shown a block diagram depicting an exemplary architecture 30 for implementing at least a portion of a system according to an embodiment of the invention on a distributed computing network. According to the embodiment, any number of clients 33 may be provided. Each client 33 may run software for implementing client-side portions of the present invention; clients may comprise a system 20 such as that illustrated in FIG. 14. In addition, any number of servers 32 may be provided for handling requests received from one or more clients 33. Clients 33 and servers 32 may communicate with one another via one or more electronic networks 31, which may be in various embodiments any of the Internet, a wide area network, a mobile telephony network (such as CDMA or GSM cellular networks), a wireless network (such as WiFi, WiMAX, LTE, and so forth), or a local area network (or indeed any network topology known in the art; the invention does not prefer any one network topology over any other). Networks 31 may be implemented using any known network protocols, including for example wired and/or wireless protocols.

[0091] In addition, in some embodiments, servers 32 may call external services 37 when needed to obtain additional information, or to refer to additional data concerning a particular call. Communications with external services 37 may take place, for example, via one or more networks 31. In various embodiments, external services 37 may comprise web-enabled services or functionality related to or installed on the hardware device itself. For example, in an embodiment where client applications 24 are implemented on a smartphone or other electronic device, client applications 24 may obtain information stored in a server system 32 in the cloud or on an external service 37 deployed on one or more of a particular enterprise's or user's premises.

[0092] In some embodiments of the invention, clients 33 or servers 32 (or both) may make use of one or more specialized services or appliances that may be deployed locally or remotely across one or more networks 31. For example, one or more databases 34 may be used or referred to by one or more embodiments of the invention. It should be understood by one having ordinary skill in the art that databases 34 may be arranged in a wide variety of architectures and using a wide variety of data access and manipulation means. For example, in various embodiments one or more databases 34 may comprise a relational database system using a structured query language (SQL), while others may comprise an alternative data storage technology such as those referred to in the art as "NoSQL" (for example, HADOOP CASSANDRA™, GOOGLE BIGTABLE™, and so forth). In some embodiments, variant database architectures such as column-oriented databases, in-memory databases, clustered databases, distributed databases, or even flat

file data repositories may be used according to the invention. It will be appreciated by one having ordinary skill in the art that any combination of known or future database technologies may be used as appropriate, unless a specific database technology or a specific arrangement of components is specified for a particular embodiment herein. Moreover, it should be appreciated that the term "database" as used herein may refer to a physical database machine, a cluster of machines acting as a single database system, or a logical database within an overall database management system. Unless a specific meaning is specified for a given use of the term "database", it should be construed to mean any of these senses of the word, all of which are understood as a plain meaning of the term "database" by those having ordinary skill in the art.

[0093] Similarly, most embodiments of the invention may make use of one or more security systems 36 and configuration systems 35. Security and configuration management are common information technology (IT) and web functions, and some amount of each are generally associated with any IT or web systems. It should be understood by one having ordinary skill in the art that any configuration or security subsystems known in the art now or in the future may be used in conjunction with embodiments of the invention without limitation, unless a specific security 36 or configuration system 35 or approach is specifically required by the description of any specific embodiment.

[0094] FIG. 16 shows an exemplary overview of a computer system 40 as may be used in any of the various locations throughout the system. It is exemplary of any computer that may execute code to process data. Various modifications and changes may be made to computer system 40 without departing from the broader scope of the system and method disclosed herein. Central processor unit (CPU) 41 is connected to bus 42, to which bus is also connected memory 43, nonvolatile memory 44, display 47, input/output (I/O) unit 48, and network interface card (NIC) 53. I/O unit 48 may, typically, be connected to keyboard 49, pointing device 50, hard disk 52, and real-time clock 51. NIC 53 connects to network 54, which may be the Internet or a local network, which local network may or may not have connections to the Internet. Also shown as part of system 40 is power supply unit 45 connected, in this example, to a main alternating current (AC) supply 46. Not shown are batteries that could be present, and many other devices and modifications that are well known but are not applicable to the specific novel functions of the current system and method disclosed herein. It should be appreciated that some or all components illustrated may be combined, such as in various integrated applications, for example Qualcomm or Samsung system-on-a-chip (SOC) devices, or whenever it may be appropriate to combine multiple capabilities or functions into a single hardware device (for instance, in mobile devices such as smartphones, video game consoles, in-vehicle computer systems such as navigation or multimedia systems in automobiles, or other integrated hardware devices).

[0095] In various embodiments, functionality for implementing systems or methods of the present invention may be distributed among any number of client and/or server components. For example, various software modules may be implemented for performing various functions in connection

with the present invention, and such modules may be variously implemented to run on server and/or client components.

[0096] The skilled person will be aware of a range of possible modifications of the various embodiments described above. Accordingly, the present invention is defined by the claims and their equivalents.

What is claimed is:

1. A system for range of motion analysis and balance training while exercising, comprising:
 an exercise machine; and
 a first sensor connected to or integrated into the exercise machine, and configured to detect the angle of a user's torso away from vertical; and
 at least one additional sensor connected to or integrated into the exercise machine configured to detect the range of motion of at least one portion of the user's body; and
 a range of motion analyzer, comprising at least a plurality of programming instructions stored in the memory of, and operating on at least one processor of, a computing device, wherein the plurality of programming instructions, when operating on the processor, cause the computing device to:
 receive data from the at least one additional sensor;
 receive or obtain statistical data regarding range of motion norms for people of different ages;
 receive or obtain stored user profile data for the current user of the compatible exercise machine;
 perform a plurality of analyses of the user's range of motion;
 create a profile of the user's range of motion relative to statistical norms, prior history, and the virtual reality or mixed reality environment associated with the user's exercise;
 display the results to the user in graphical or textual form; and
 a balance trainer, comprising at least a plurality of programming instructions stored in the memory of, and operating on at least one processor of, a computing device, wherein the plurality of programming instructions, when operating on the processor, cause the computing device to:
 receive data from the first sensor;
 calculate, based on the data from the first sensor and the rate of change of that data, when the user is likely to stumble or fall; and
 display a warning to the user in graphical or textual form to train the user to learn to anticipate and correct stumbles and falls.

2. The system of claim 1, wherein the user's data is stored to track changes in range of motion and balance over time.

3. The system of claim 1, further comprising a computing device capable of rendering a virtual reality or mixed reality environment wherein the exercise machine, computing device, and the system are configured to operate in conjunction, providing exercise with a virtual reality or mixed reality environment and range of motion analysis and balance training.

4. A method for range of motion analysis and balance training while exercising, comprising the steps of:

detecting and characterizing the angle of a user's torso away from vertical position, using a sensor and exercise machine;

detecting and characterizing the range of motion of at least one portion of a user's body, using an additional sensor and an exercise machine;

receiving or obtaining statistical data regarding range of motion norms for people of different ages, using a range of motion analyzer;

receiving or obtaining stored user profile data for the current user of the compatible exercise machine, using a range of motion analyzer;

performing a plurality of analyses of the user's range of motion, using a range of motion analyzer;

creating a profile of the user's range of motion relative to statistical norms, prior history, and the virtual reality or mixed reality environment associated with the user's exercise, using a range of motion analyzer;

displaying the results to the user in graphical or textual form;

informing a user if they are likely to fall, based at least in part on data from the first sensor and the rate of change of that data, using a balance trainer and a first sensor; and

displaying a warning to a user in graphical or textual form in order to improve a user's ability to anticipate and correct stumbles or falls through improved exercise form, using a balance trainer and display.

5. The method of claim 4, wherein the user's data is stored to track changes in range of motion and balance over time.

6. The method of claim 4, further comprising a computing device capable of rendering a virtual reality or mixed reality environment wherein the exercise machine, computing device, and the system are configured to operate in conjunction, providing exercise with a virtual reality or mixed reality environment and range of motion analysis and balance training.

* * * * *