



US 20200261716A1

(19) **United States**

(12) **Patent Application Publication**
Gibson et al.

(10) **Pub. No.: US 2020/0261716 A1**

(43) **Pub. Date: Aug. 20, 2020**

(54) **IMPLANT MAGNET SYSTEM**

11/857,397, filed on Sep. 18, 2007, now Pat. No. 8,255,058, which is a continuation of application No. 10/820,444, filed on Apr. 8, 2004, now abandoned.

(71) Applicants: **Peter Gibson**, South Coogee (AU);
Charles Roger Aaron Leigh, North Epping (AU); **Frank Risi**, Newtown (AU); **David Walker**, Lane Cove (AU)

(30) **Foreign Application Priority Data**

Apr. 9, 2003 (AU) 2003901696

(72) Inventors: **Peter Gibson**, South Coogee (AU);
Charles Roger Aaron Leigh, North Epping (AU); **Frank Risi**, Newtown (AU); **David Walker**, Lane Cove (AU)

Publication Classification

(21) Appl. No.: **16/796,058**

(51) **Int. Cl.**
A61N 1/08 (2006.01)
A61N 1/378 (2006.01)
A61N 1/375 (2006.01)
(52) **U.S. Cl.**
CPC *A61N 1/08* (2013.01); *A61N 1/375* (2013.01); *A61N 1/3787* (2013.01)

(22) Filed: **Feb. 20, 2020**

Related U.S. Application Data

(60) Continuation of application No. 16/046,635, filed on Jul. 26, 2018, which is a division of application No. 15/010,627, filed on Jan. 29, 2016, now Pat. No. 10,058,702, which is a continuation of application No. 14/866,156, filed on Sep. 25, 2015, now Pat. No. 10,232,171, which is a continuation of application No. 13/596,912, filed on Aug. 28, 2012, now Pat. No. 9,144,676, which is a continuation of application No.

(57) **ABSTRACT**

A magnetic alignment system that can form part of a cochlear implant system. The magnetic alignment system prevents substantial movement of a magnet of an implanted component during an MRI procedure or allows for easy removal of the magnet to facilitate the MRI procedure.

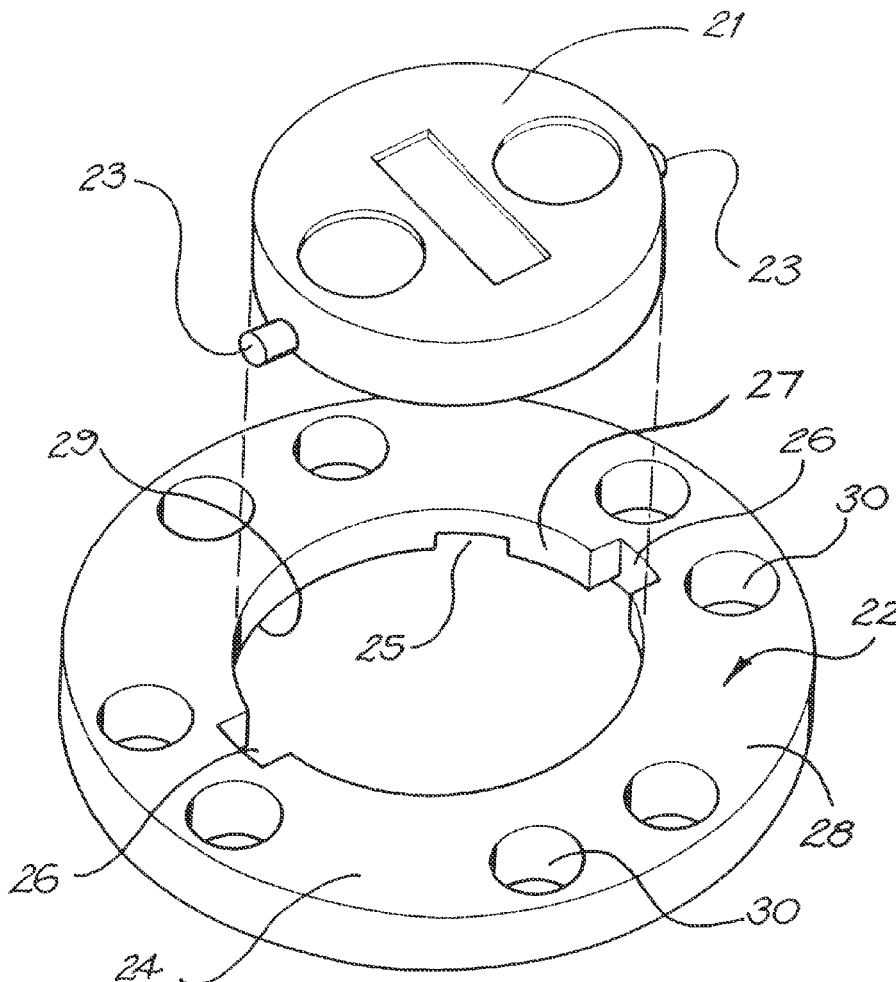

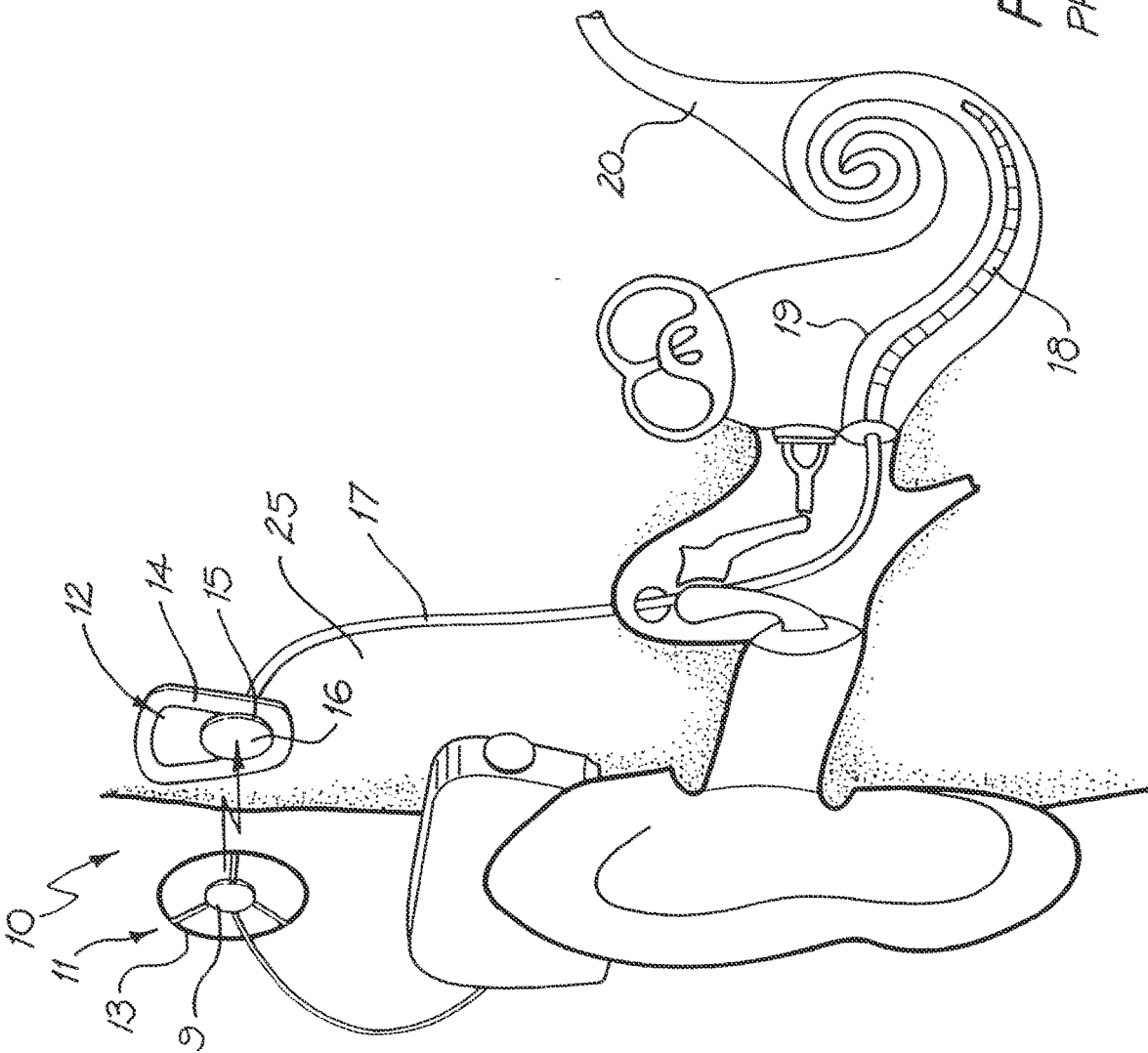

FIG. 1
PRIOR ART

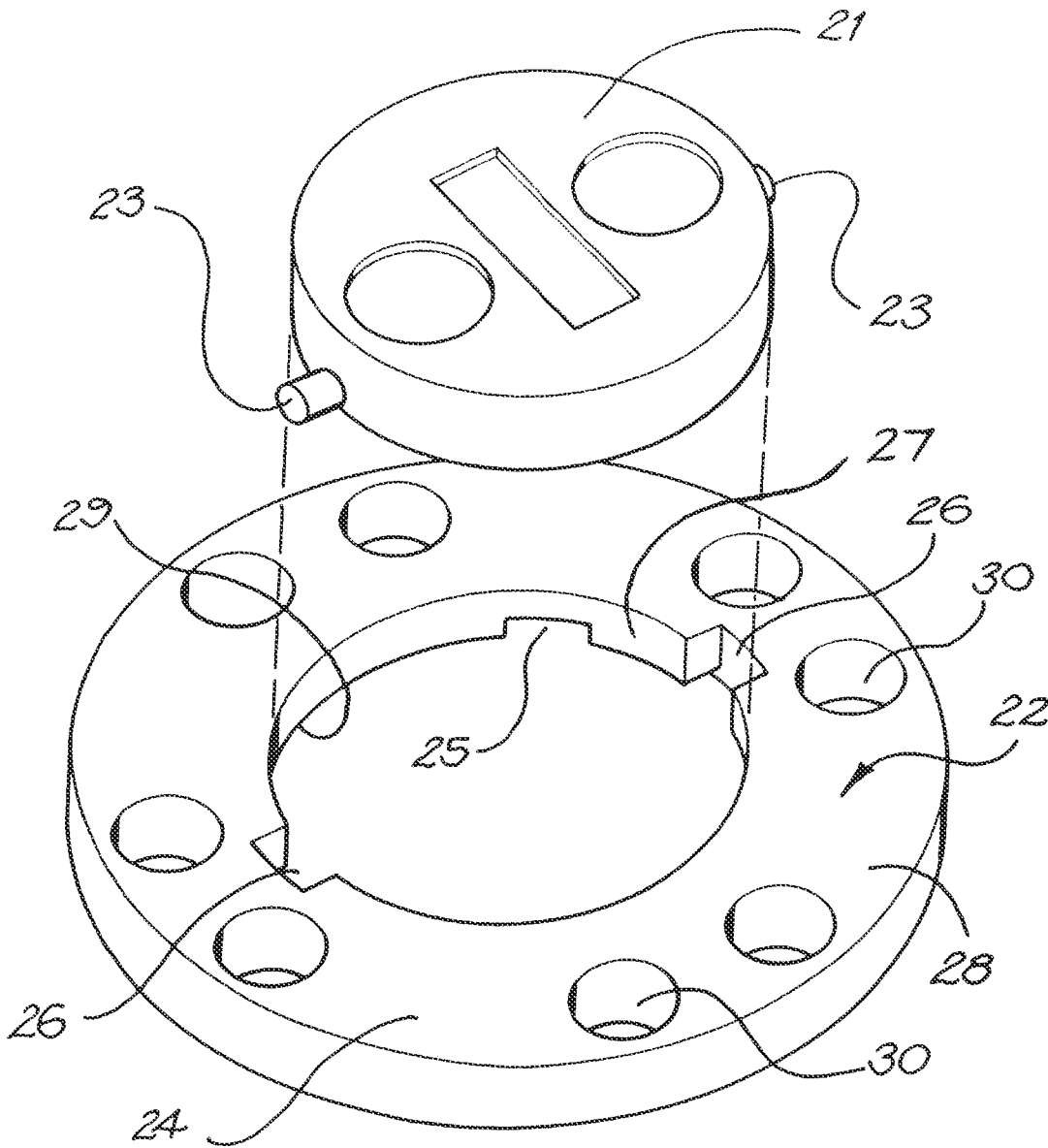

FIG. 2a

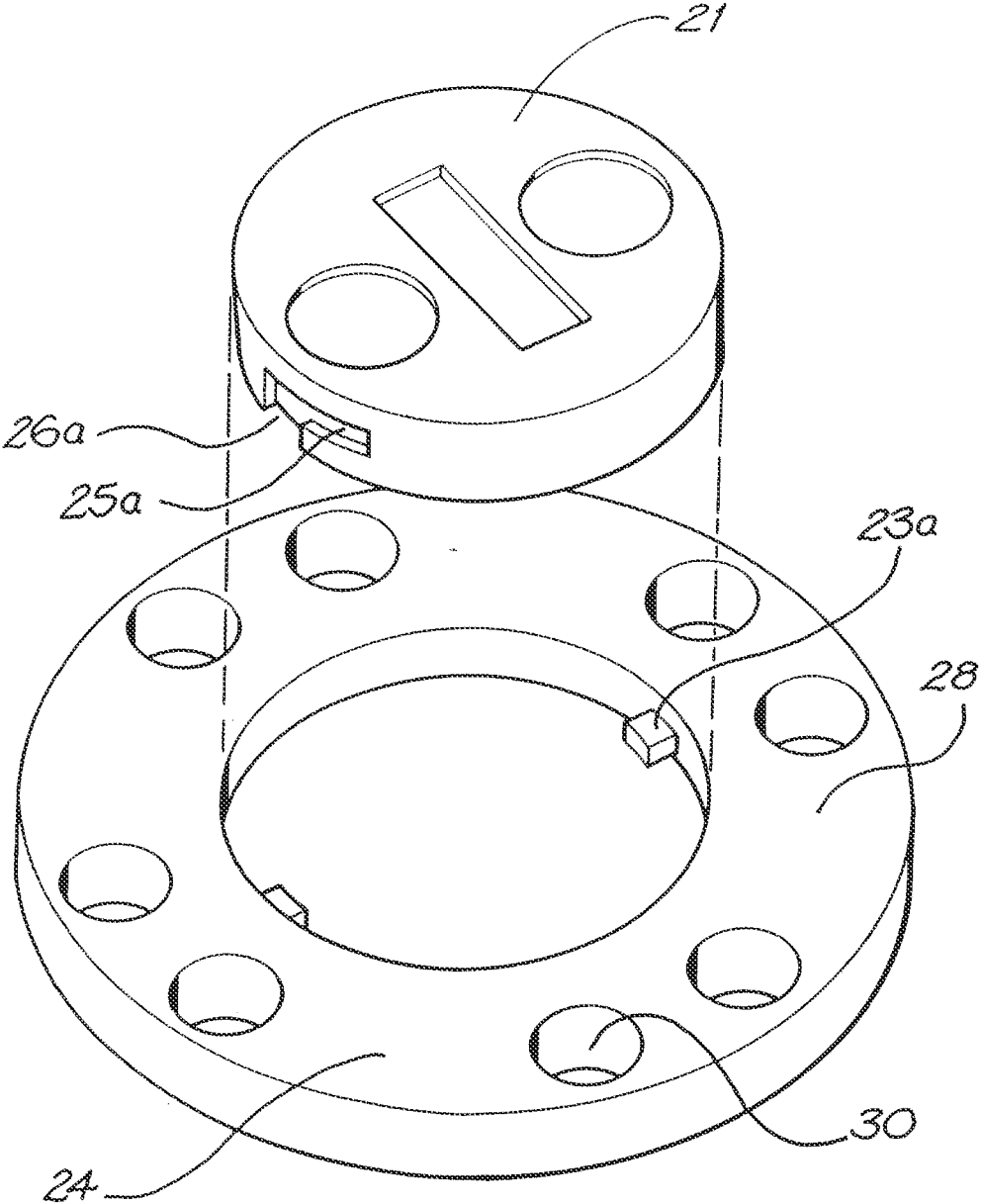

FIG 2 b

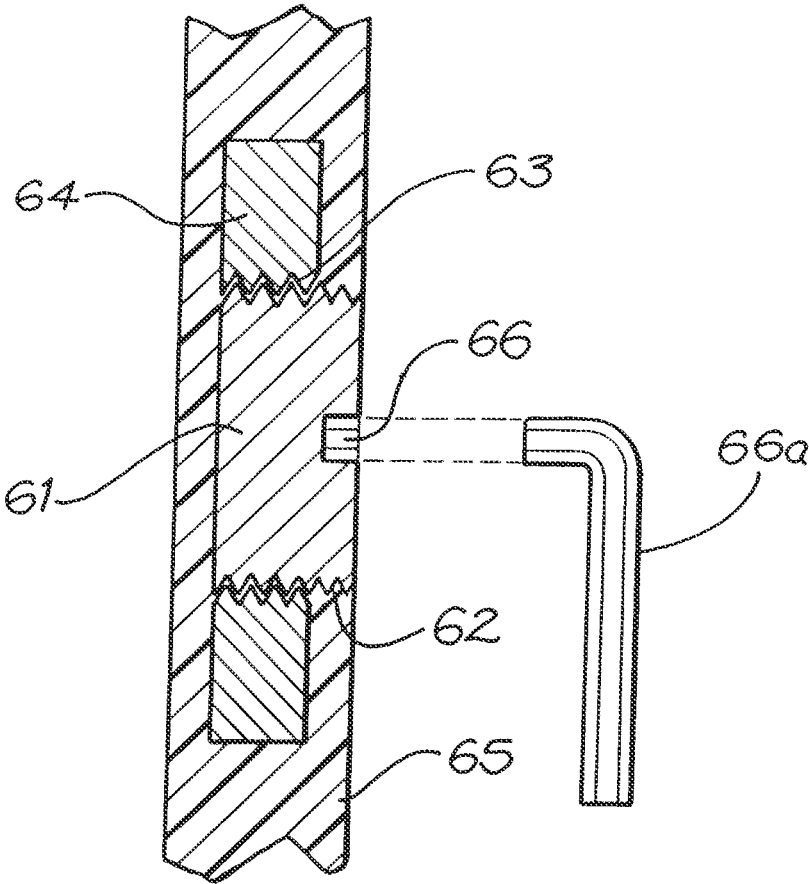

FIG 3

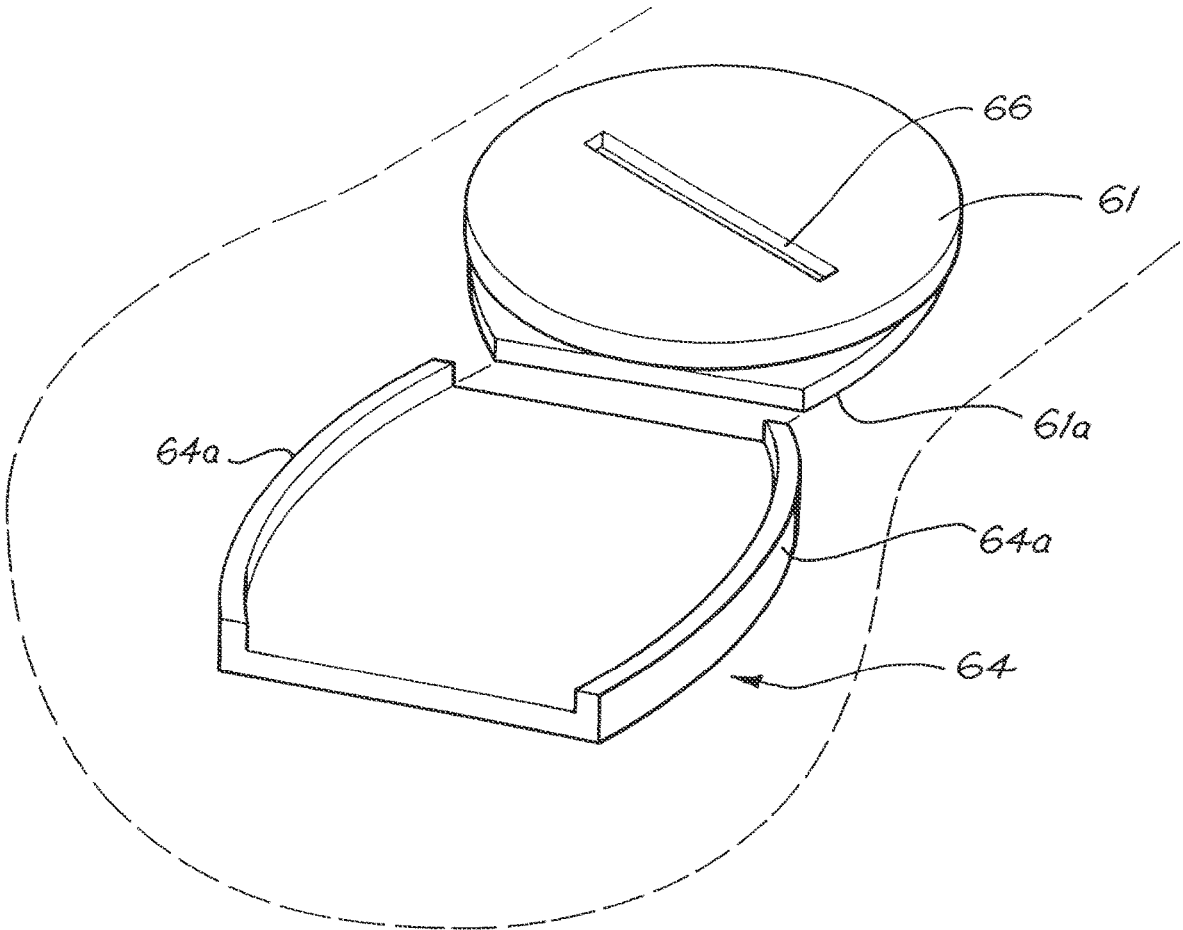

FIG. 3 a

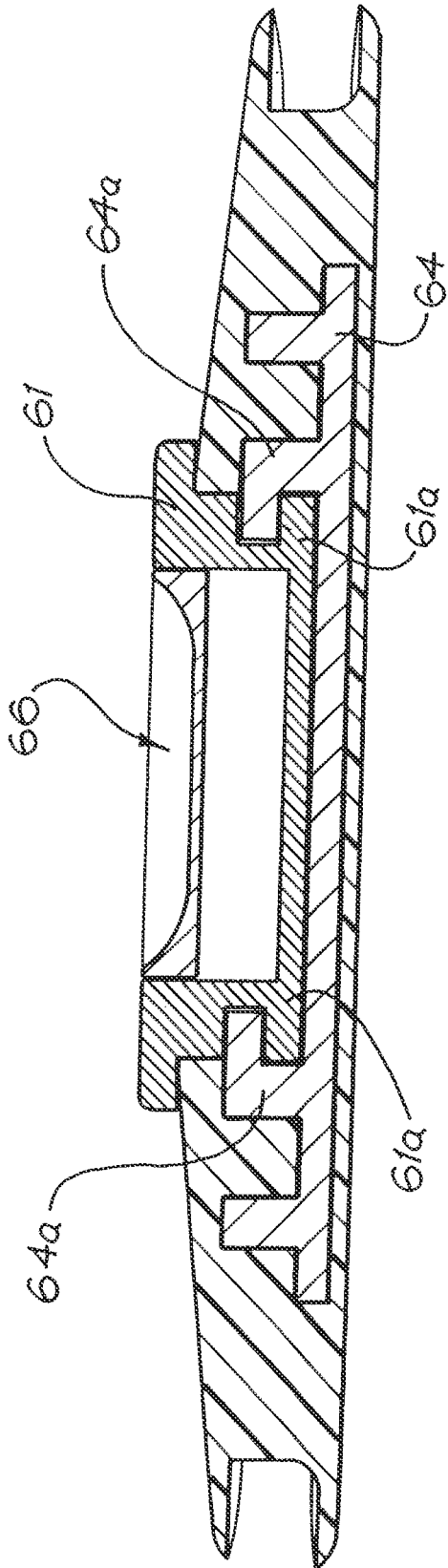

FIG. 3b

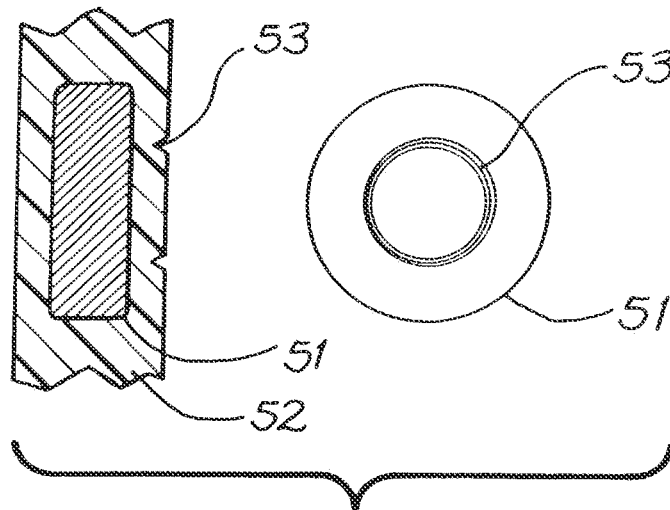

FIG. 4

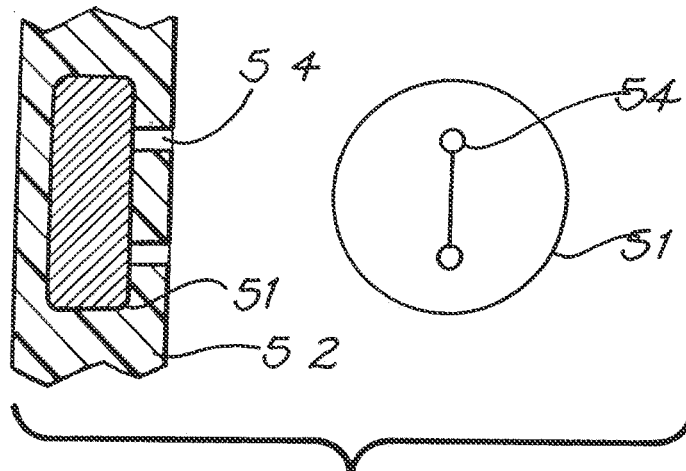

FIG. 4a

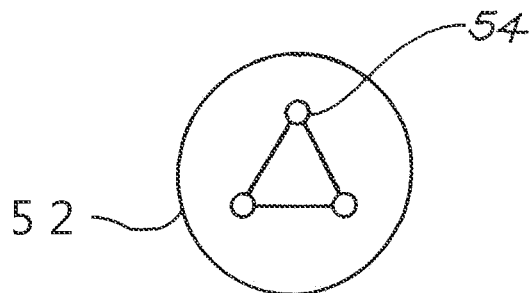

FIG. 4b

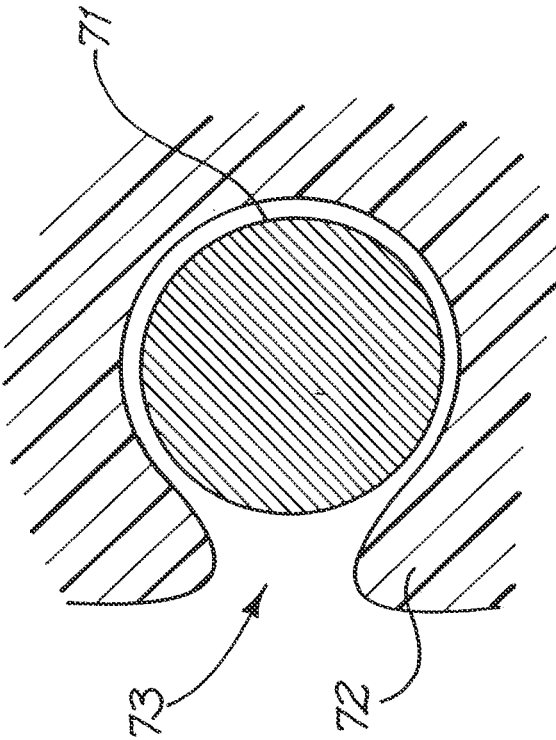

FIG. 5b

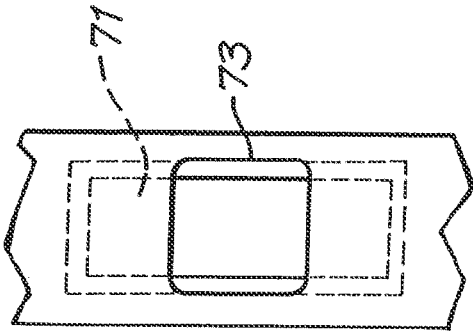

FIG. 5a

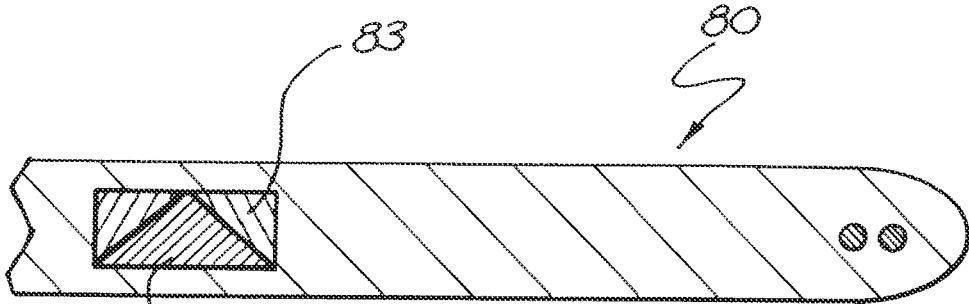

FIG. 6a

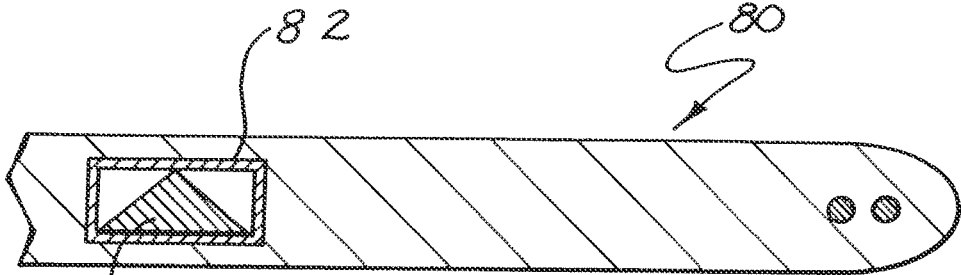

FIG. 6b

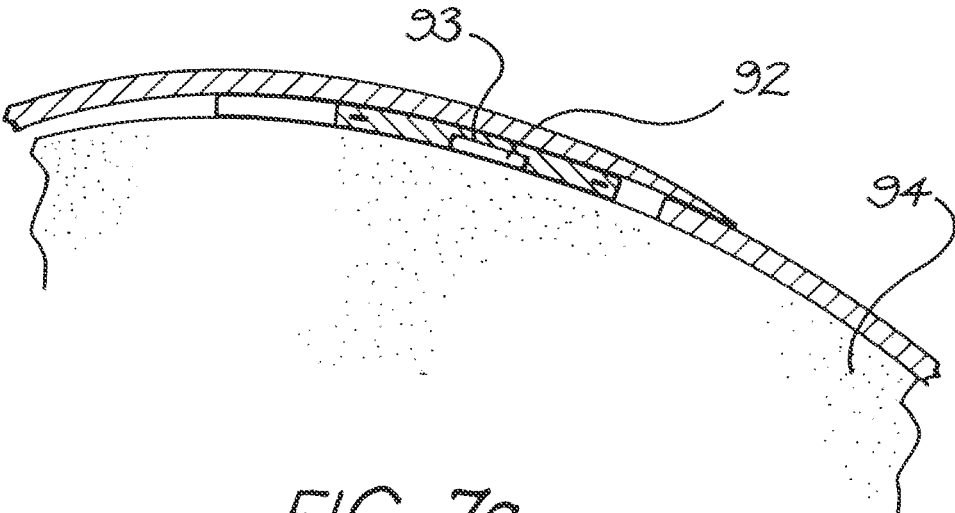

FIG. 7a

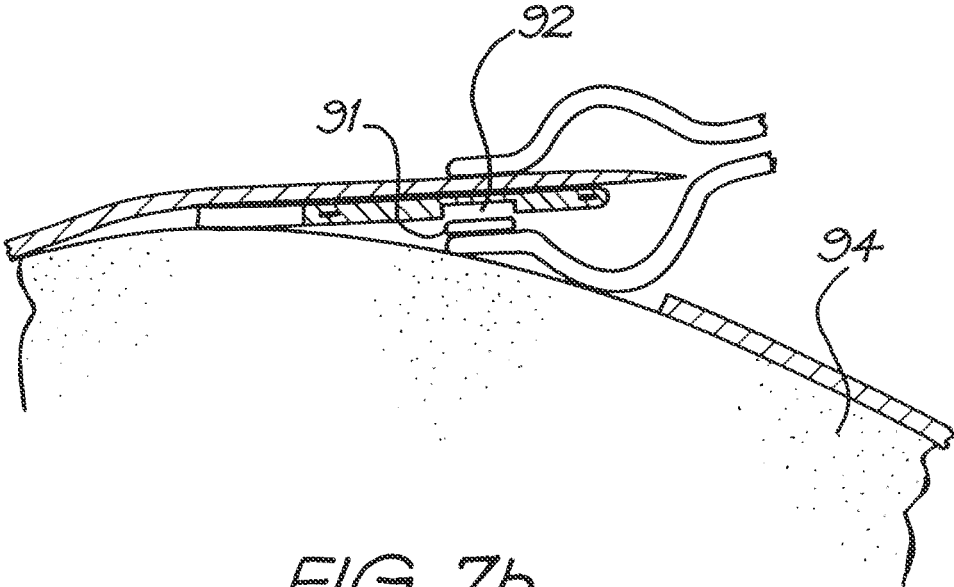

FIG. 7b

FIG. 8a

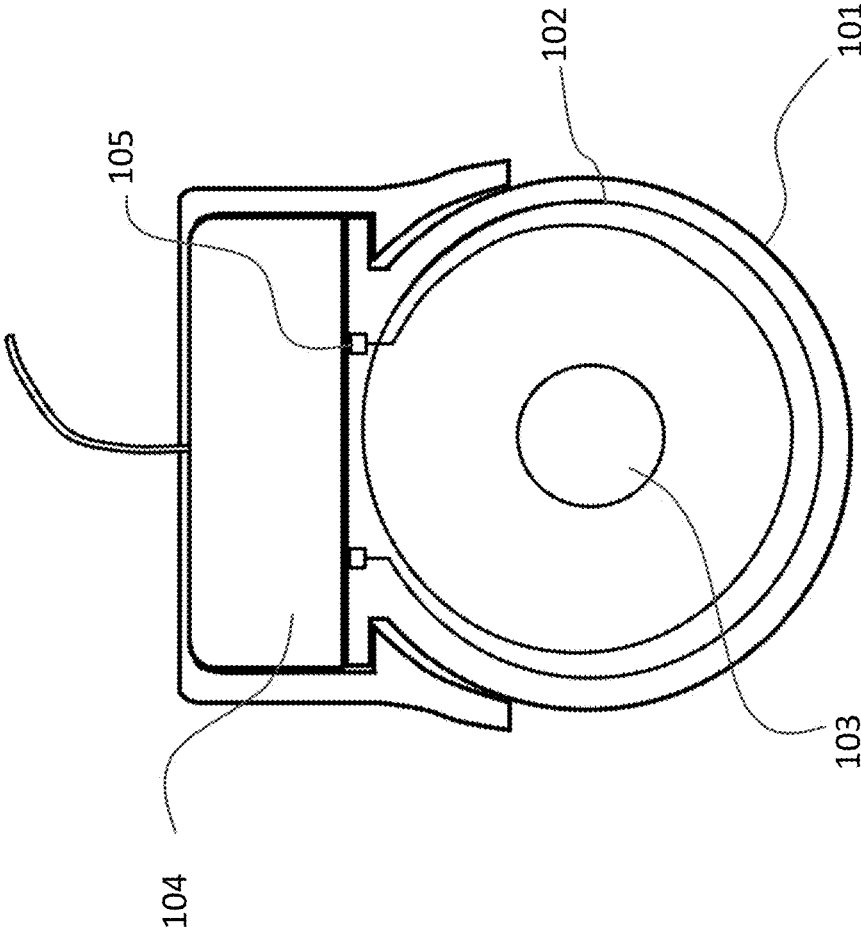
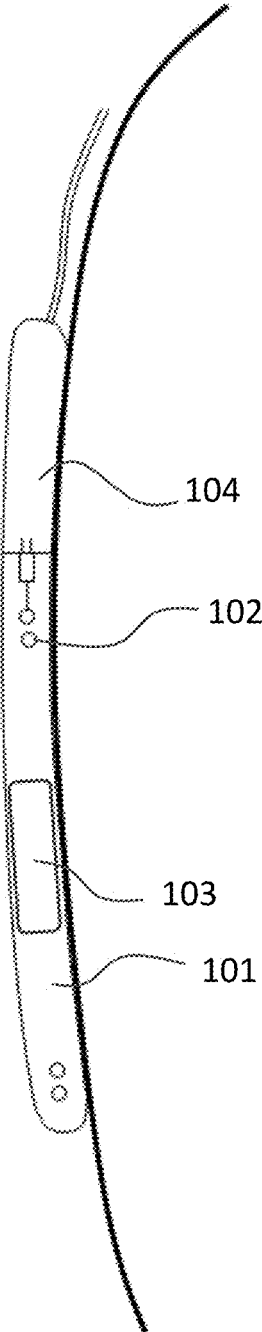

FIG. 8b



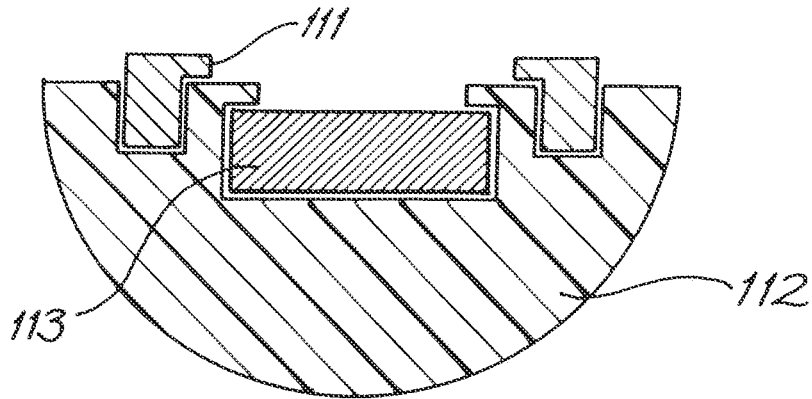

FIG. 9a

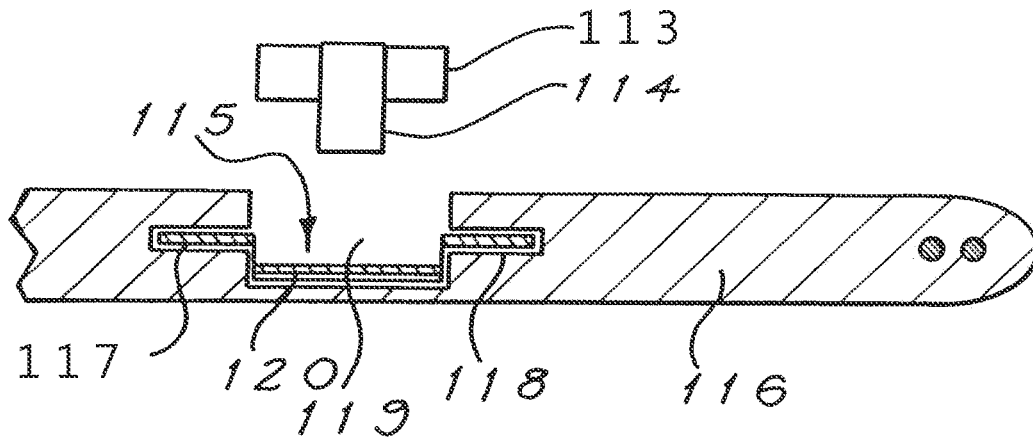

FIG. 9b

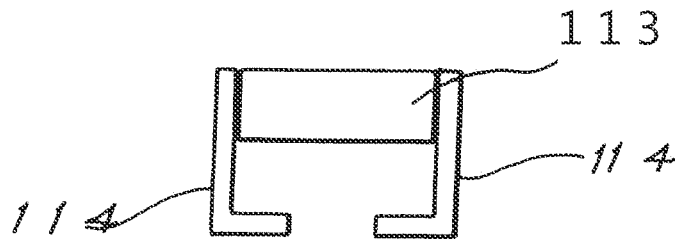

FIG. 9c

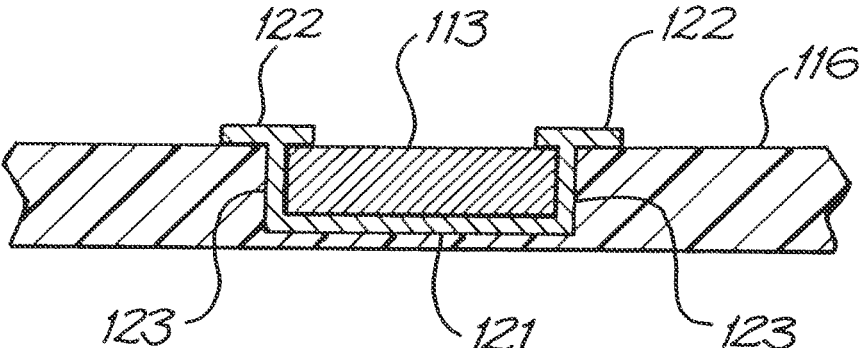

FIG. 10a

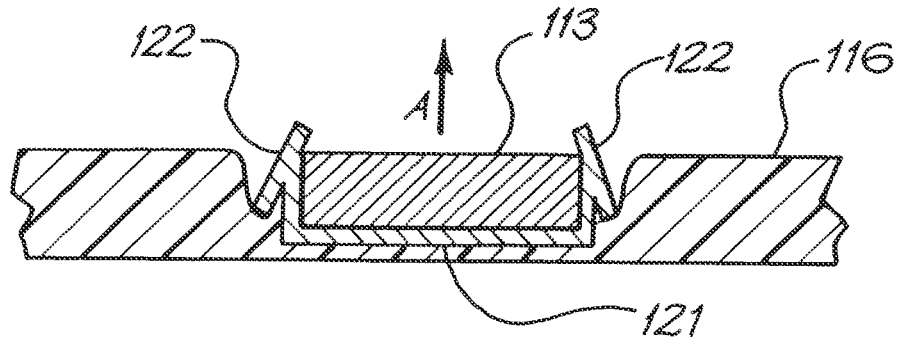

FIG. 10b

IMPLANT MAGNET SYSTEM

CROSS-REFERENCE TO RELATED APPLICATIONS

[0001] The present application is a continuation application of U.S. patent application Ser. No. 11/857,397 filed Sep. 18, 2007, now U.S. Pat. No. 8,255,058 issued Aug. 28, 2012, which claims priority from U.S. patent application Ser. No. 10/820,444, filed on Apr. 8, 2004, which claims priority from Australian Provisional Application No 2003901696, filed Apr. 9, 2003, the contents of which are incorporated herein by reference.

BACKGROUND

Field of the Invention

[0002] The present invention relates to a cochlear implant and in particular to an MRI-compatible implantable component of a cochlear implant.

[0003] Cochlear implant systems bypass the hair cells in the cochlea and directly deliver electrical stimulation to the auditory nerve fibres, thereby allowing the brain to perceive a hearing sensation resembling the natural hearing sensation normally delivered to the auditory nerve.

[0004] Typically, cochlear implant systems have consisted of essentially two components, an external component commonly referred to as a processor unit and an internal implanted component commonly referred to as a stimulator/receiver unit. Traditionally, both of these components have cooperated together to provide the sound sensation to a user.

[0005] The external component may consist of a microphone for detecting sounds, a speech processor that converts the detected sounds, particularly speech, into a coded signal, a power source such as a battery, and an external transmitter antenna.

[0006] The coded signal output by the speech processor is transmitted transcutaneously to the implanted stimulator/receiver unit that can be situated within a recess of the temporal bone of the implantee. This transcutaneous transmission occurs via the external transmitter antenna which is positioned to communicate with an implanted receiver antenna provided with the stimulator/receiver unit.

[0007] The implanted stimulator/receiver unit traditionally includes a receiver antenna that receives the coded signal and power from the external processor component, and a stimulator that processes the coded signal and outputs a stimulation signal to an intracochlear electrode assembly which applies the electrical stimulation directly to the auditory nerve producing a hearing sensation corresponding to the original detected sound.

[0008] The commonly accepted method of providing the implanted stimulator with power and information is to transmit RF-power via an inductively coupled antenna coil system. In such a system, the external transmitter coil is usually positioned on the side of an implantee's head directly facing the implanted coil of the stimulator/receiver unit to allow for the transmission of the coded sound signal and power from the speech processor to the implanted unit. Such transmitters usually have a coil formed by a small number of turns of a single or multi-strand wire and a magnet at or near the hub of the coil. The magnet holds the transmitter coil in place due to magnetic attraction with a magnet of the implanted unit.

[0009] The implanted magnet can pose problems for those cochlear implant implantees that may be required to undergo magnetic resonance imaging (MRI). In this regard, although studies have indicated that MRI presents no major risk to such implantees, the magnetic fields used in MRI procedures have been shown to exert a torque force on the implanted magnet. This torque force, if significantly large, such as may be the case if a high field strength MRI is undertaken, has the potential to cause undesirable consequences such as dislodgement of the magnet from its casing as well as discomfort to the implantee. There is also the potential for significant distortion of the image obtained by MRI due to the presence of the magnet in the implantee's head, which may significantly negate the usefulness of the process.

SUMMARY

[0010] Throughout this specification the word "comprise", or variations such as "comprises" or "comprising", will be understood to imply the inclusion of a stated element, integer or step, or group of elements, integers or steps, but not the exclusion of any other element, integer or step, or group of elements, integers or steps.

[0011] In a first aspect, there is provided a magnetic alignment system for a transcutaneous transmitter/receiver system, said magnetic alignment system comprising an external transmitter unit and an implantable receiver component, both the external transmitter unit and the implantable receiver component having a magnet positioned therein to allow transcutaneous alignment of said external transmitter unit and said implantable receiver component; **[0012]** the system being characterised in that an outer surface of the magnet, or a casing for the magnet, of the implantable receiver component has an engagement surface that is engageable with a complementary engagement surface formed in a mounting of the implantable receiver component.

[0012] In a second aspect, there is provided a magnetic alignment system for a transcutaneous transmitter/receiver system, said magnetic alignment system comprising an external transmitter unit and an implantable receiver component, both the external transmitter unit and the implantable receiver component having a magnet positioned therein to allow transcutaneous alignment of said external transmitter unit and said implantable receiver component; **[0014]** the system being characterised in that the magnet of the implantable receiver component is housable within a pocket formed in a suitable biocompatible flexible mounting, said pocket having a restricted opening formed therein through which the magnet is insertable but which is sized to retain the magnet within the pocket following insertion.

[0013] In a third aspect, there is provided a magnetic alignment system for a transcutaneous transmitter/receiver system, said magnetic alignment system comprising an external transmitter unit and an implantable receiver component, both the external transmitter unit and the implantable receiver component having a magnet positioned therein to allow transcutaneous alignment of said external transmitter unit and said implantable receiver component; **[0016]** the system being characterised in that the magnet of the implantable receiver component is housed within a suitable biocompatible flexible mounting, said mounting having one or more indicia thereon or therein that identify the location of the magnet within the mounting

[0014] In a fourth aspect, there is provided a magnetic alignment system for a transcutaneous transmitter/receiver system, said magnetic alignment system comprising an external transmitter unit and an implantable receiver component, both the external transmitter unit and the implantable receiver component having a magnet positioned therein to allow transcutaneous alignment of said external transmitter unit and said implantable receiver component; [0018] the system being characterised in that the magnet is releasably held within the receiver component by one or more retaining devices.

[0015] In a fifth aspect, there is provided a magnetic alignment system for a transcutaneous transmitter/receiver system, said magnetic alignment system comprising an external transmitter unit and an implantable receiver component, both the external transmitter unit and the implantable receiver component having a magnet positioned therein to allow transcutaneous alignment of said external transmitter unit and said implantable receiver component; [0020] the system being characterised in that the magnet of the implantable receiver component is housed within a recess formed in a suitable biocompatible flexible mounting, said recess being locatable adjacent the skull of the implantee in use thereby ensuring the magnet is held in the recess between the receiver component and the skull of the implantee

[0016] In a sixth aspect, there is provided a magnetic alignment system for a transcutaneous transmitter/receiver system, said magnetic alignment system comprising an external transmitter unit and an implantable receiver component, the external transmitter unit having a magnet positioned therein and the implantable receiver component having a magnetised insert positioned therein to allow transcutaneous alignment of said external transmitter unit and said implantable receiver component; [0022] the magnetised insert of the implantable receiver component having a first end and a second end and increasing in width away from said first end towards said second end, the first end being positionable closer to the skin of the implantee in use to ensure self-centering of the magnet of the external transmitter unit with the magnetised insert of the receiver component

[0017] In a seventh aspect, there is provided a magnetic alignment system for a transcutaneous transmitter/receiver system, said magnetic alignment system comprising an external transmitter unit and an implantable receiver component, both the external transmitter unit and the implantable receiver component having a magnet positioned therein to allow transcutaneous alignment of said external transmitter unit and said implantable receiver component; [0024] the system being characterised in that the implantable receiver component is detachably connectable to an implantable tissue stimulator device.

[0018] In an eighth aspect, there is provided a cochlear implant system comprising an external transmitter unit positionable on the outside of an implantee's head and an implantable receiver component positionable subcutaneously, wherein said external transmitter unit and said implantable receiver component each comprise a magnet therein to hold the external transmitter unit substantially in transcutaneous alignment with the implantable receiver component; wherein an outer surface of the magnet, or a casing for the magnet, of the implantable receiver component has an engagement surface that is engageable with a

complementary engagement surface formed in a mounting of the implantable receiver component.

[0019] In a ninth aspect, there is provided a cochlear implant system comprising an external transmitter unit positionable on the outside of an implantee's head and an implantable receiver component positionable subcutaneously, wherein said external transmitter unit and said implantable receiver component each comprise a magnet therein to hold the external transmitter unit substantially in transcutaneous alignment with the implantable receiver component and wherein the magnet of the implantable receiver component is housable within a pocket formed in a suitable biocompatible flexible mounting, said pocket having a restricted opening formed therein through which the magnet is insertable but which is sized to retain the magnet within the pocket following insertion.

[0020] In a tenth aspect, there is provided a cochlear implant system comprising an external transmitter unit positionable on the outside of an implantee's head and an implantable receiver component positionable subcutaneously, wherein said external transmitter unit and said implantable receiver component each comprise a magnet therein to hold the external transmitter unit substantially in transcutaneous alignment with the implantable receiver component; wherein the magnet of the implantable receiver component is housed within a suitable biocompatible flexible mounting, said mounting having one or more indicia thereon or therein that identify the location of the magnet within the mounting

[0021] In an eleventh aspect, there is provided a cochlear implant system comprising an external transmitter unit positionable on the outside of an implantee's head and an implantable receiver component positionable subcutaneously, wherein said external transmitter unit and said implantable receiver component each comprise a magnet therein to hold the external transmitter unit substantially in transcutaneous alignment with the implantable receiver component; wherein the magnet is releasably held within the receiver component by one or more retaining devices.

[0022] In a twelfth aspect, there is provided a cochlear implant system comprising an external transmitter unit positionable on the outside of an implantee's head and an implantable receiver component positionable subcutaneously, wherein said external transmitter unit and said implantable receiver component each comprise a magnet therein to hold the external transmitter unit substantially in transcutaneous alignment with the implantable receiver component; wherein the magnet of the implantable receiver component is housed within a recess formed in a suitable biocompatible flexible mounting, said recess being locatable adjacent the skull of the implantee in use thereby ensuring the magnet is held in the recess between the receiver component and the skull of the implantee.

[0023] In a thirteenth aspect, there is provided a cochlear implant system comprising an external transmitter unit positionable on the outside of an implantee's head and an implantable receiver component positionable subcutaneously, wherein the external transmitter unit has a magnet positioned therein and the implantable receiver component has a magnetised insert positioned therein to allow transcutaneous alignment of said external transmitter unit and said implantable receiver component; [0031] the magnetised insert of the implantable receiver component having a first end and a second end and increasing in width away from

said first end towards said second end, the first end being positionable closer to the skin of the implantee in use to ensure self-centering of the magnet of the external transmitter unit with the magnetised insert of the receiver component.

[0024] In a fourteenth aspect, there is provided a cochlear implant system comprising an external transmitter unit positionable on the outside of an implantee's head and an implantable receiver component positionable subcutaneously, wherein said external transmitter unit and said implantable receiver component each comprise a magnet therein to hold the external transmitter unit substantially in transcutaneous alignment with the implantable receiver component; the system being characterised in that the implantable receiver component is detachably connectable to an implantable cochlea stimulator device

BRIEF DESCRIPTION OF THE DRAWINGS

[0025] By way of example only, exemplary embodiments are now described with reference to the accompanying drawings, in which:

[0026] FIG. 1 is a pictorial representation of a cochlear implant system;

[0027] FIG. 2a is a schematic view of a magnet and mounting of one example of the invention;

[0028] FIG. 2b depicts another arrangement for mounting the magnet in the receiver component;

[0029] FIG. 3 depicts a still further arrangement for mounting the magnet in the receiver component;

[0030] FIGS. 3a and 3b depict a still further arrangement for mounting the magnet in the receiver component;

[0031] FIGS. 4, 4a and 4b depict arrangements for identifying the location of the magnet in the mounting of the receiver component;

[0032] FIGS. 5a and 5b depict an alternative arrangement for mounting the magnet in the receiver component;

[0033] FIGS. 6a and 6b depict another arrangement for ensuring magnetic alignment of the receiver component with the external transmitter component;

[0034] FIG. 7a depicts a further arrangement for mounting the magnet in the receiver component;

[0035] FIG. 7b depicts how the magnet can be removed from the receiver component shown in FIG. 7a;

[0036] FIGS. 8a and 8b depict an arrangement in which the receiver coil can be disconnected from the stimulator component; and

[0037] FIGS. 9a, 9b, 9c, 10a, and 10b depict various arrangements for retaining the magnet in the receiver component using one or more manipulable clips.

DETAILED DESCRIPTION

[0038] Exemplary embodiments of a magnetic alignment system according to the present invention are generally depicted in the accompanying drawings as part of a cochlear implant system.

[0039] As depicted pictorially in FIG. 1, the magnetic alignment system 10 of a cochlear implant system comprises an external transmitter unit 11 and an implantable receiver component 12.

[0040] The external transmitter unit 11 comprises a transmitter antenna coil 13 which transmits coded signals to the implantable receiver component 12 via a radio frequency (RF) link.

[0041] The implantable receiver component 12 of the system comprises a receiver antenna coil 14 for receiving power and data from the transmitter coil 13 and a stimulator unit 15 within a housing 16. A cable 17 extends from the stimulator unit 15 to the cochlea and terminates in an electrode array 18. The signals received are applied by the array 18 to the basilar membrane 19 thereby stimulating the auditory nerve 20.

[0042] The receiver coil 14 typically comprises a wire antenna coil comprised of at least one and preferably two turns of electrically insulated platinum or gold wire.

[0043] The implantable receiver component 12 has a magnet to allow transcutaneous alignment of the external transmitter unit 11 (which also has a magnet 9) and the implantable receiver component 12.

[0044] The electrical insulation of the antenna coil is provided by a flexible silicone molding. In use, the implantable receiver component 12 can be positioned in a recess of the temporal bone adjacent the ear of an implantee.

[0045] Arrangements for preventing any or at least reducing substantial movement of the magnet of a transcutaneous transmitter/receiver system, such as a cochlear implant system, while a recipient is undergoing MRI scans of relatively low field strengths and arrangements that allow removal of the magnet from within the implantee if necessary, (such as when the recipient is to undergo MRI scans of relatively high field strengths) are depicted in the remaining drawings.

[0046] In the embodiment depicted in FIG. 2a, the implantable receiver component of a cochlear implant system has a magnet 21 and a mounting 22. An outer surface of the magnet 21 has an engagement surface that is engageable with a complementary engagement surface formed in the mounting 22. The engagement between the magnet 21 and the mounting 22 minimises movement of the magnet, particularly when a patient undergoes an MRI procedure. Examples of the engagement surface and the complementary engagement surface are described in more detail below.

[0047] In FIG. 2a, the magnet 21 has two extension members 23 that extend from opposite sides of the magnet. The magnet 21 may be received by the mounting 22 which is shown in FIG. 2 as a ring 24.

[0048] The ring 24 has at least one recessed portion 25. In an exemplary embodiment, the ring 24 includes two recessed portions 25 although in FIG. 2a, the second recessed portion is obscured from view. The recessed portions 25 receive the extension members 23 of the magnet 21 and hold the magnet in place within the ring 24.

[0049] The ring further includes two slots 26 in an inner surface 27 of the ring 24. The slots 26 extend from an upper surface 28 of the ring 24 to a lower surface 29 of the ring 24, i.e. through the thickness of the ring 24.

[0050] The magnet 21 may be relatively lowered into the center of the ring 24 such that the extension members 23 pass through slots 26. When moved beyond the lower surface 29 of the ring 24, the magnet is then rotatably moveable relative to the ring 24.

[0051] The magnet 21 may be rotated until the extension members align with the recessed portions 25.

[0052] The ring 24 may sit on, or at least partially within, a resilient silicone body of the implantable receiver component. To insert the magnet 21 into the center of the ring, a degree of force is therefore required to cause the extension member 23 to pass through the slots 26 and beyond the lower surface 29 of the ring 24. Once the magnet 21 is

rotated and the extension members 23 are in alignment with the recessed portions 25, release of any force applied to the magnet 21 will result in the silicone body causing the extension members 23 to move up and away from the lower surface 29 of the ring and into the recessed portions 25. With the extension members 23 housed within the recessed portions 25, the magnet 21 is no longer rotatably moveable relative to the ring 24 (unless a degree of downward force is again applied to the magnet 21 to dislodge the extension members from the recessed portions).

[0053] The magnet 21 is, therefore, substantially but removably locked in place within the mounting 22.

[0054] Referring now to FIG. 2b, an alternative arrangement is shown in which the extension members 23a extend inwardly from the ring 24, and are arranged to engage with corresponding recessed portions 25a provided on the magnet 21. The number of slots 26a is shown as two, however, it is envisaged that one larger extension member 23a on the ring 24 could be used together with a corresponding single slot on the magnet 21.

[0055] Further, the ring 24 as shown in FIG. 2a has a series of holes 30 extending therethrough. The silicone of the implantable receiver component may extend through the holes 30 and provides a means of securing the ring 24 to the silicone body of the implantable receiver component. In this regard, portions of silicone may extend through the holes 30 and essentially act as rivets to mechanically lock the ring 24 in place. This added level of security may be desirable when the magnet is subjected to MRI and particularly to high field strengths.

[0056] In this aspect, the engagement surface of the magnet or the magnet casing can be a screw thread. The complementary engagement surface of the mounting can also be a screw thread that is formed in the mounting. In one embodiment, the mounting has a ring member mounted therein. The internal surface of the ring member may form the complementary engagement surface and may be a screw thread. The ring member can be made of a ceramic or plastics material. The mounting can be formed from a suitable biocompatible silicone.

[0057] As depicted in FIG. 3, the magnet can be screwed into or unscrewed from the mounting.

[0058] In FIG. 3, the outer surface of magnet 61 has a screw thread 62 formed therein. The screw thread 62 is engageable with a complementary thread 63 formed in a mounting ring 64 within the implantable component body (here depicted as 65). The mounting ring 64 can be made of a metal, ceramic or plastics material while the body 65 can be formed from a suitable biocompatible material, such as silicone.

[0059] As depicted, a top surface of the magnet 61 can have a slot 66 formed therein that can receive a tool, such as an allen key 66a as shown, or a screwdriver or the like, to facilitate turning of the magnet and its removal from the mounting ring 64.

[0060] In another embodiment, the engagement surface of the magnet may be held in place within the mounting by friction fit. As described in more detail below, the outer surface of the magnet, or casing of the magnet, can be shaped in a specific configuration, allowing for insertion of the magnet or part of the magnet into the mounting element. In this regard, the complementary engagement surface of the mounting will be compatible with the shape of the outer surface of the magnet or magnet casing such that the outer

surface can be inserted into the mounting element. Once the outer surface of the magnet or magnet casing has been at least partially inserted into the mounting element, the magnet or magnet casing may be rotated, for example a ¼ or ½ turn, thereby causing the shape of the engagement surface of the magnet or magnet casing to no longer be compatible with the shape of the complementary engagement surface of the mounting element. This thereby provides an interference fit preventing inadvertent removal of the magnet from the mounting element. In this embodiment, the magnet may be easily removed by merely rotating the magnet the appropriate amount such that the shape of the engagement surface of the magnet means is compatible with the shape of the complementary engagement surface of the mounting element, thereby allowing easy removal of the magnet.

[0061] This particular embodiment is depicted in FIG. 3a wherein magnet 61 is provided with a pedestal element 61a for securing within the mounting element 64. In the depicted embodiment, the mounting element 64, is substantially trapezoidal in shape with two upright walls 64a, being curved in configuration. The pedestal element 61a of the magnet 61 has a similar shape to that of the mounting element 64, namely it has a shape consisting of two substantially parallel sides joined at both ends by curved portions. The pedestal is remote from the bottom face of the magnet 61, thereby forming a space between the pedestal element 61a and the magnet 61. The inner surfaces of the upright walls 64a of the mounting element 64 can be provided with a recess to receive the curved end portions of the pedestal element 61a when the pedestal is placed within the mounting element 64 for engagement.

[0062] In this regard, the magnet 61 is rotatable relative to the mounting. The magnet may be rotated 90 degrees to the position shown in FIG. 3a for locating within the mounting element 64. Once the magnet 61 is placed in position with the pedestal element 61a located between the walls 64a of the mounting element 64, the magnet is then rotated 90 degrees such that the curved walls of the pedestal element 61a are received within the recessed curved walls of the mounting element 64. In this regard, the magnet is secured in place and is fixed within the mounting element 64 as shown in FIG. 3b. To remove the magnet 61 from the mounting element 64 in the event, for example, of an MRI procedure, the magnet 61 is rotated such that the pedestal element 61a is no longer held in place within the walls 64a of the mounting element. The magnet can then be relatively easily removed. A screwdriver or other such tool can be used to assist in this procedure, via the slot 66.

[0063] As is shown in FIGS. 3a and 3b as the dotted line and the hashed area respectively, the magnet 61 and mounting element 64 are preferably secured in a flexible biocompatible material such as silicone. In this regard, the silicone can be arranged so as to overlap the walls of the mounting element 64 such that when the magnet 61 is placed in position for securing, as described above, the surrounding material may be compressed between the magnet 61 and the mounting element 64. In this regard, the compression force may aid in securing the magnet in place when rotated into the secured position. Further, such an arrangement may further seal the arrangement from the ingress of body fluids into the mounting element 64.

[0064] In another embodiment, a spring-type force can be provided to aid in the interference fit by providing a bias force between the engagement surfaces of the magnet and

the mounting element, such that when the two surfaces are in non-alignment, the magnet will be securely held in place. Such a biasing force can be provided by placing a spring means or spring member in the mounting for receiving the magnet, or by providing a compressive material such as silicone within the mounting, that is compressed once the magnet is inserted into the mounting and provides a force that biases the magnet against the mounting.

[0065] A further aspect of the invention is depicted in FIGS. 4, 4a and 4b. The magnet (here depicted as 51) of the implantable receiver component is housed within a suitable biocompatible flexible silicone mounting 52. In FIG. 4, the mounting 52 has a circular indentation 53 formed therein that acts as an indicia and serves to assist in identifying the location of the magnet 51 within the mounting 52. During surgery to remove the magnet 51, the ring 53 will indicate to the surgeon the location of the magnet 51 within the mounting 52. The indentation can also serve as a guide to a scalpel blade used to cut through the mounting 52 to access the magnet 51.

[0066] In the embodiment depicted in FIGS. 4a and 4b, the indicia can comprise two or more holes 54 formed in the silicone. The holes 54 again act as guides to a surgeon having to cut the magnet 51 from the mounting 52. That is, they identify where the mounting 52 should be cut to allow removal of the magnet 51 held therein.

[0067] FIGS. 5a and 5b depict a still further arrangement wherein the magnet 71 of the implantable receiver component is housed within a pocket 72 formed in a wall of the biocompatible flexible mounting. The pocket 72 has a restricted opening 73 formed therein through which the magnet 71 can be inserted but which is sized to retain the magnet 71 within the pocket 72 following insertion during normal use.

[0068] FIGS. 6a and 6b depict a still further arrangement, in which the external transmitter unit (not depicted in FIGS. 6a and 6b) has a magnet positioned therein while the implantable receiver component (here depicted as 80) has a conical, non-magnetised ferro-magnetic insert 81 positioned therein to allow transcutaneous alignment of the external transmitter unit and the implantable receiver component. The non-magnetised insert 81 of the implantable receiver component has a first end and a second end and increases in width away from the first end towards the second end, the first end being adapted to be positioned closer to the skin of the implantee to ensure self-centering of the magnet of the external transmitter unit with the insert 81 of the receiver component. While depicted as a conical structure, the magnetised insert be other shapes such as a frusto-conical shape.

[0069] The non-magnetised insert 81 can be mounted in a non-magnetic support within the receiver component. In one embodiment, the support can be a titanium case 82 as depicted in FIG. 6b. In another embodiment, as depicted in FIG. 6a, a suitable non-magnetic material, such as plastic, ceramic or titanium, stop member 83 can lock the insert 81 in the receiver component.

[0070] While the insert 81 can be removable, the use of a non-magnetised insert 81 rather than a magnet has the advantage of reducing the magnetic force on the receiver component during an MRI scan if it is left in place.

[0071] In FIGS. 7a and 7b, the magnet 91 of the implantable receiver component (here depicted as 92) is housed within a recess 93 formed in a suitable biocompatible flexible mounting. The recess 93 is adapted to be located

adjacent the skull 94 of the implantee in use thereby ensuring the magnet 91 is held in the recess 93 between the receiver component 92 and the skull 94 of the implantee.

[0072] In this embodiment, the magnet 91 can be removed from the recess by incising the skin of the implantee and then gently lifting the receiver component 92 away from the skull a distance sufficient to allow a surgeon to reach under the receiver component and remove the magnet 91 from the recess 93, as is depicted in FIG. 7b.

[0073] FIGS. 8a and 8b depict a further arrangement in which the mounting 101 housing the receiver coil 102 and magnet 103 is detachably connectable to an implantable tissue stimulator device (here depicted as 104). Electrical connection is made between the receiver component and the tissue stimulator device when the component is connected to the stimulator device. A pin and socket arrangement can be used to provide the electrical connection.

[0074] As depicted, the electrical connection is made between the coil 102 and the circuitry of the tissue stimulator device 104 by a pin and socket arrangement 105. Once connection is made, the pin and socket arrangement is preferably constructed such that there is no ingress of bodily fluids into either the stimulator device 104 or the mounting 101. In one embodiment, the socket can be mounted to the stimulator device and the pin or pins to the receiver component. An arrangement where the socket is part of the receiver component and the pin or pins are part of the stimulator device can be equally envisaged.

[0075] If the implantee is to undergo an MRI scan, an incision can be made in the implantee, and the receiver component detached from the tissue stimulator device. The entire receiver component, as defined in this aspect, is then removed rather than just the magnet. Once the MRI scan is complete, the receiver component can be re-implanted and the necessary connection again made between the receiver component and the stimulator device.

[0076] Mounting 101 is detachable from the tissue stimulator device 104 and may be removed prior to an MRI procedure. Once the MRI scan is complete, the mounting 101 can be re-implanted and the necessary connection again made between the coil 102 and the stimulator device 104.

[0077] In FIGS. 9a, 9b, 9c, 10a and 10b various systems that rely on one or more clips to removably hold the magnet within the receiver component are depicted.

[0078] The clips can be mounted on the receiver component and adapted to engage the magnet positioned therein or thereon. In another embodiment, the clips can be mounted to the magnet or a casing thereof and are engageable with the receiver component. The clips may be manipulable by a surgeon.

[0079] FIG. 9a depicts a compression clip 111 that can be used to compress a silicone pocket 112 around a magnet (here depicted as 113). The clip 111 can be removed by a surgeon if removal of the magnet 113 is required.

[0080] In the embodiment depicted in FIGS. 9b and 9c, two clips 114 are mounted on the magnet 113 and are engageable with a socket member 115 that is itself removably engageable in the receiver component (here depicted as 116). The socket member 115 has a main member 120 and two wing members 117. The wing members 117 are engageable within recesses 118 extending laterally from a main recess 119 formed in the receiver component 116. When the socket member 115 is positioned within the main recess 119

and the wing members 117 are engaged with the lateral recesses 118, the main member 120 is suspended across the main recess 119.

[0081] The clips 114 of the magnet 113 are preferentially biased inwardly and as such must be moved out and around the main member 120 on insertion. Once the lower ends of the clips 114 have moved relatively below the main member 120, the clips 114 can be released and so engage under the main member 120. If it is desired to remove the magnet 113, the clips 114 are pulled relatively apart by the surgeon thereby allowing the magnet 113 to be drawn up and out of the main recess 119.

[0082] An alternative arrangement for using a clip to retain the magnet 113 in the receiver component 116 is depicted in FIGS. 10a and 10b. In this embodiment, a clip 121 is positioned underneath the magnet 113. The clip 121 is supported in the silicone body of the receiver component and has two lips 122 that preferentially hold the magnet 113 in place during normal use. If it is desired to remove the magnet 113, the lips 122 are pushed down into the resilient silicone body 116 and pivot about uprights 123 so allowing the magnet 113 to be popped out of the receiver component 116 in the direction of arrow A.

[0083] The cochlear implant system described above enables an implantee to undergo an MRI procedure without removing the magnet of an implant, such as a cochlear implant, or provides a system enabling easy removal of the magnet to facilitate an MRI procedure at relatively higher field strengths. Such a system is particularly useful for those implantees requiring regular MRI scans.

[0084] It will be appreciated by persons skilled in the art that numerous variations and/or modifications may be made to the invention as shown in the specific embodiments without departing from the spirit or scope of the invention as broadly described. The present embodiments are, therefore, to be considered in all respects as illustrative and not restrictive.

1-20. (canceled)

21. An implantable medical device, comprising:

a first implantable component including a receiver antenna; and

a second implantable component including a functional electronics device, wherein

the first implantable component is removably connected to the second implantable component such that the receiver antenna is in breakable electrical connection with the functional electronic device.

22. The implantable medical device of claim 21, wherein: the implantable medical device includes a pin and socket arrangement that establishes the breakable electrical connection.

23. The implantable medical device of claim 21, wherein: the implantable medical device is a hearing prosthesis; and

the functional electronics device is a device configured to generate a stimulation signal that stimulates tissue of a recipient to evoke a hearing percept.

24. The implantable medical device of claim 21, wherein: the medical device is configured such that when the connection is present, there is no ingress of body fluids into the first implantable component or the second implantable component when the implantable medical device is implanted in a recipient.

25. The implantable medical device of claim 21, wherein: the medical device includes clips that hold the first component to the second component in the removable manner.

26. The implantable medical device of claim 21, wherein: the medical device includes a male-female coupling that holds the first implantable component to the second implantable component in the removable manner.

27. The implantable medical device of claim 21, wherein the first component comprises:

a radio frequency coil; and

a magnet.

28. The implantable medical device of claim 21, wherein: the first component and the second component define a smooth upper surface and a smooth lower surface without substantial discontinuities at a junction between the respective components.

29. The implantable medical device of claim 21, wherein: the medical device includes a connector that comprises a mechanical locking mechanism that secures first component to the second component in a manner that presents tactile feedback when the first component is connected to the second component.

30. The implantable medical device of claim 21, wherein the first component comprises:

a radio frequency coil; and

a magnet, wherein

the entire magnet is contained within a space bounded by an inner perimeter of the coil.

31. An implantable medical device, comprising:

a first implantable component including a first electronics apparatus supported by a first chassis; and

a second implantable component including a second electronics apparatus supported by a second chassis, wherein

at least one of the first or second chassis forms a coupling that releasably mechanically holds the first implantable component to the second implantable component.

32. The implantable medical device of claim 31, wherein: the first implantable component includes a device configured to generate a stimulation signal that stimulates tissue of a recipient to evoke a hearing percept; and the second implantable component includes an antenna, wherein

when the first implantable component is held to the second implantable component by the coupling, the antenna is in electrical communication with the device configured to generate the stimulation signal.

33. The implantable medical device of claim 31, wherein: the first chassis forms a first portion of the coupling.

34. The implantable medical device of claim 31, wherein: the first chassis and the second chassis collectively form the coupling.

35. The implantable medical device of claim 21, wherein: the first component includes one of a male connector apparatus or a female connector apparatus and the second component includes the other of the male connector apparatus or the female connector apparatus.

36. The implantable medical device of claim 21, wherein: the coupling is a snap coupling.

37. The implantable medical device of claim 21, wherein the first component comprises:

a radio frequency coil; and

a magnet, wherein

the magnet and the coil are coaxially aligned.

38. A method, comprising:

accessing an implanted device of a medical device implanted in a recipient through an incision in skin of the recipient, the implanted device including a first component removably coupled to a second component, the second component being attached to tissue of the recipient in a manner more substantially than the first component;

uncoupling the first component from the second component without removing the second component from the recipient; and

removing the first component from the recipient without removing the second component from the recipient.

39. The method of claim **38**, wherein:

the first component is an antenna of the medical device that is in electrical communication with the second component when the first component is coupled to the second component.

40. The method of claim **38**, further comprising:

exposing the recipient to an MRI magnetic field while the first component is removed from the recipient; and replacing the first component after the exposure to the MRI magnetic field is completed.

41. The method of claim **38**, further comprising:

exposing the recipient to an MRI magnetic field while the first component is removed from the recipient; and replacing the first component, wherein the first component is an antenna of the medical device that is in electrical communication with the second component when the first component is coupled to the second component.

42. The method of claim **38**, wherein:

the action of uncoupling the first component from the second component without removing the second component from the recipient is executed by undoing a snap coupling that holds the first component to the second component.

43. The method of claim **38**, wherein:

the action of uncoupling the first component from the second component without removing the second component from the recipient includes undoing pin and socket connections that place the first component into electrical communication with the second component.

44. The method of claim **38**, further comprising:

connecting an apparatus to the second component such that the apparatus is in electrical communication with the second component and mechanically coupled to the second component.

* * * * *