



US 20200259552A1

(19) **United States**

(12) **Patent Application Publication**
ASHWORTH

(10) **Pub. No.: US 2020/0259552 A1**

(43) **Pub. Date: Aug. 13, 2020**

(54) **MULTI-AMPLIFIER REPEATER SYSTEM FOR WIRELESS COMMUNICATION**

Publication Classification

(71) Applicant: **Wilson Electronics, LLC**, St. George, UT (US)

(51) **Int. Cl.**
H04B 7/155 (2006.01)
H04B 10/25 (2006.01)
H04B 7/26 (2006.01)
H04B 10/80 (2006.01)

(72) Inventor: **Christopher Ken ASHWORTH**, Toquerville, UT (US)

(52) **U.S. Cl.**
CPC *H04B 7/15507* (2013.01); *H04B 10/2589* (2020.05); *H04B 10/807* (2013.01); *H04B 7/15535* (2013.01); *H04B 7/2606* (2013.01)

(21) Appl. No.: **16/861,101**

(22) Filed: **Apr. 28, 2020**

(57) **ABSTRACT**

Related U.S. Application Data

Technology for a multi-repeater system including wireless transmission of power from a first repeater to a second repeater is disclosed. A first and second repeater can be disposed opposite each other about a structural element. Wireless power can be transmitted from the first repeater through the structural element to the second repeater for use by the second repeater.

(63) Continuation of application No. 15/947,684, filed on Apr. 6, 2018, now Pat. No. 10,637,557.

(60) Provisional application No. 62/482,828, filed on Apr. 7, 2017.

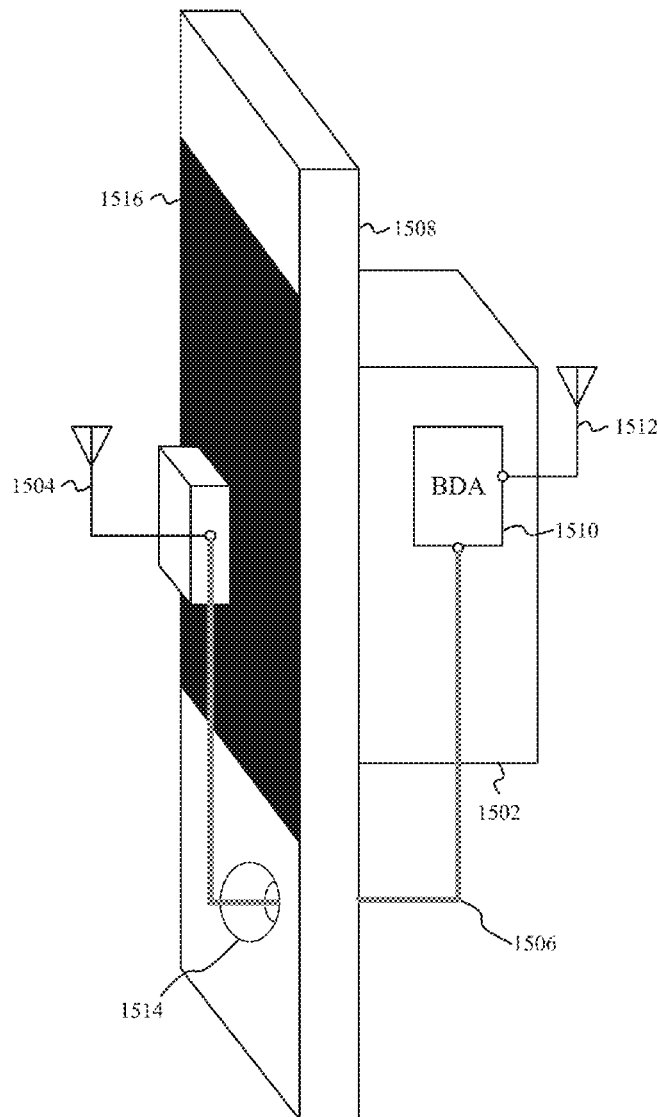

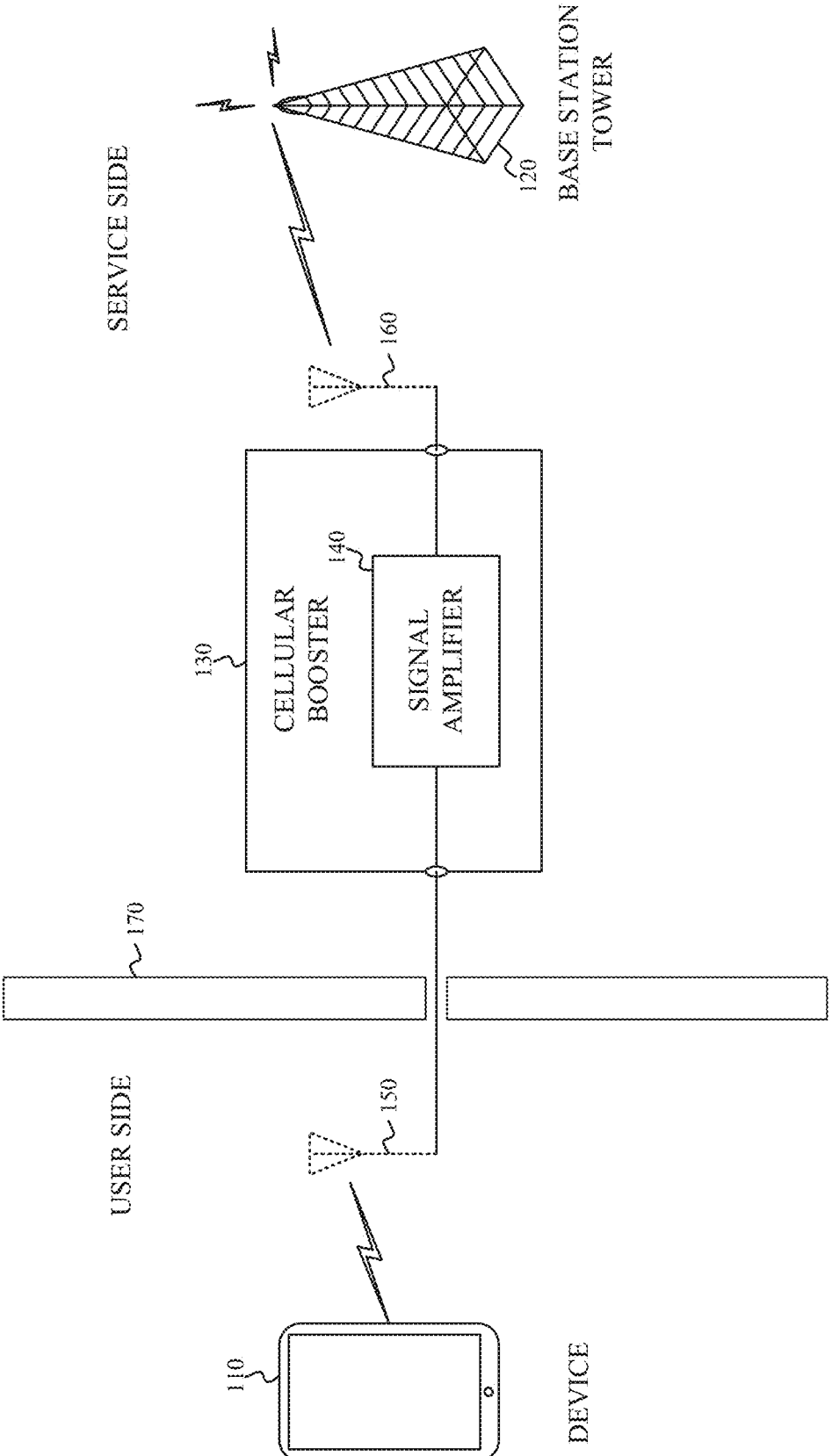

FIG. 1

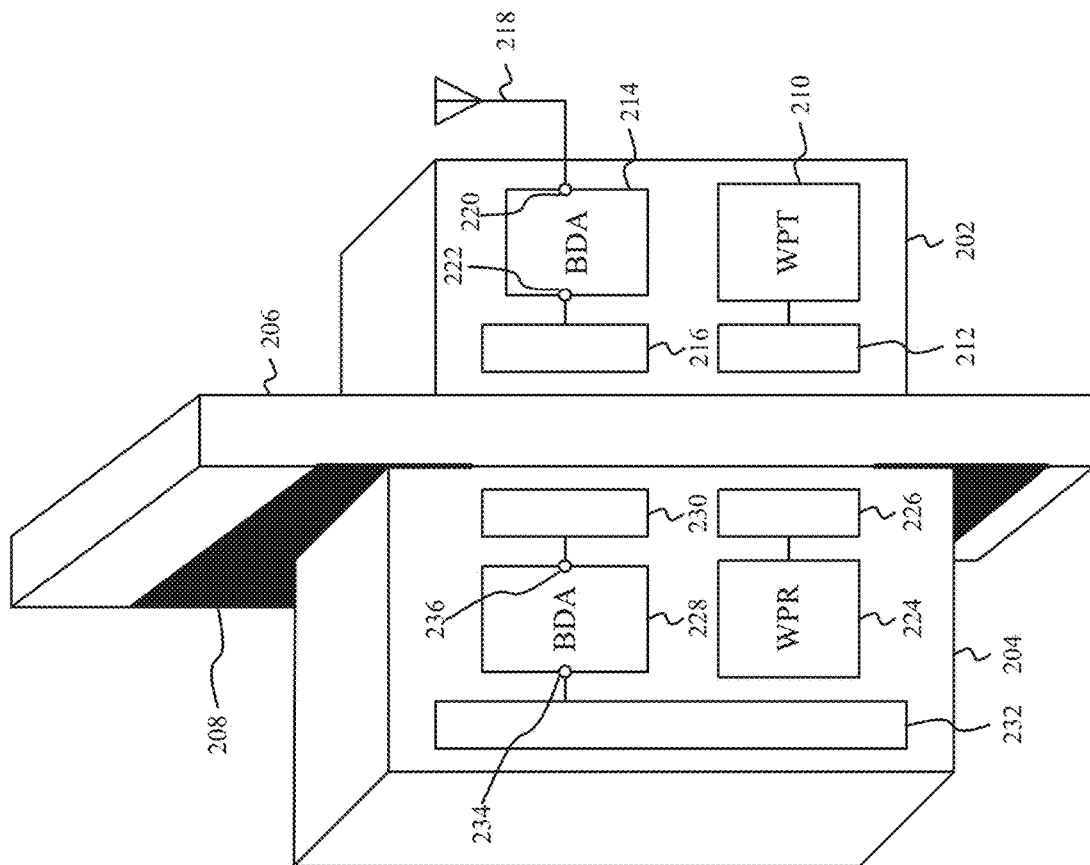

FIG. 2B

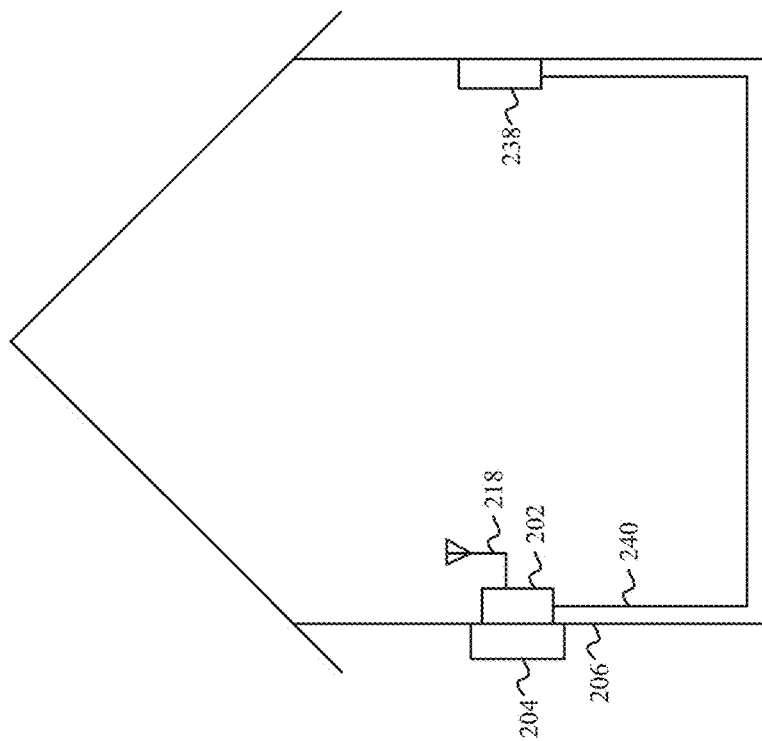

FIG. 2A

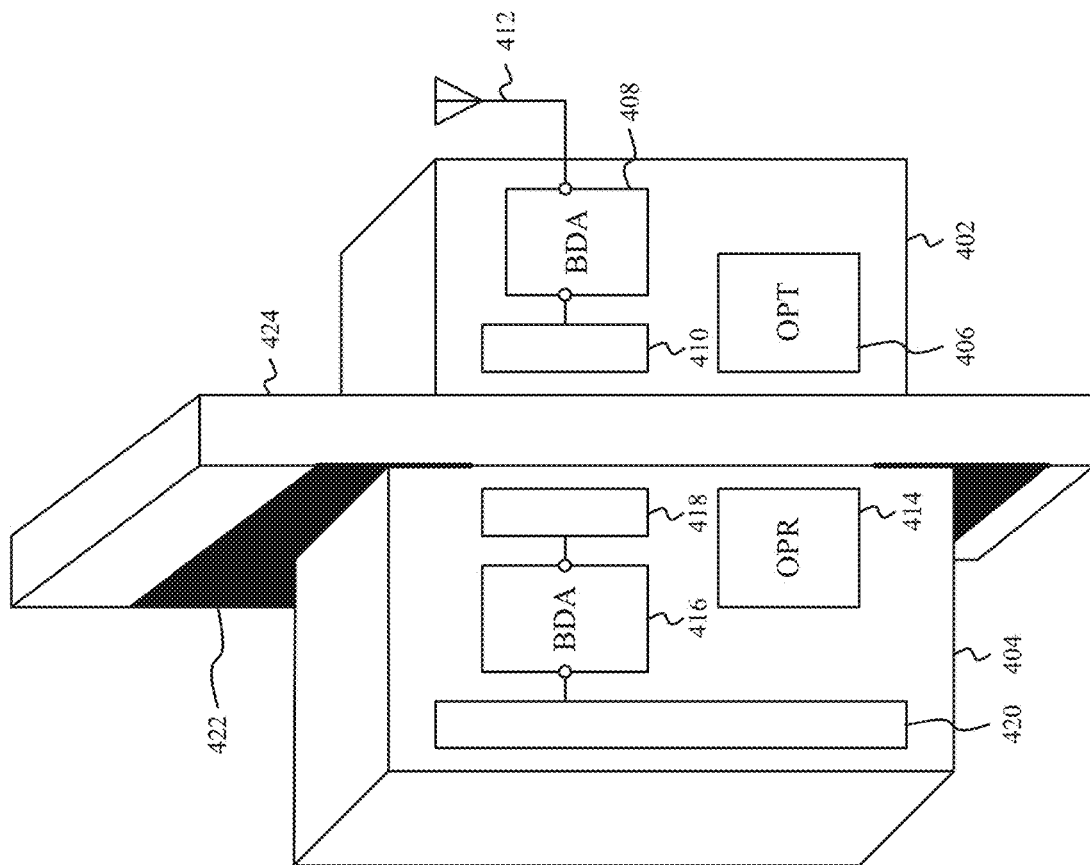

FIG. 4B

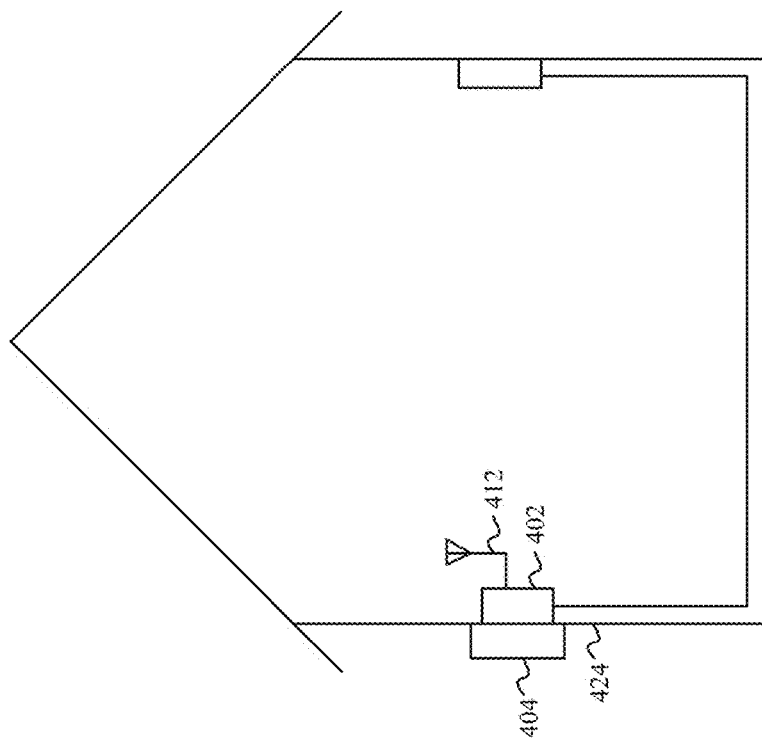

FIG. 4A

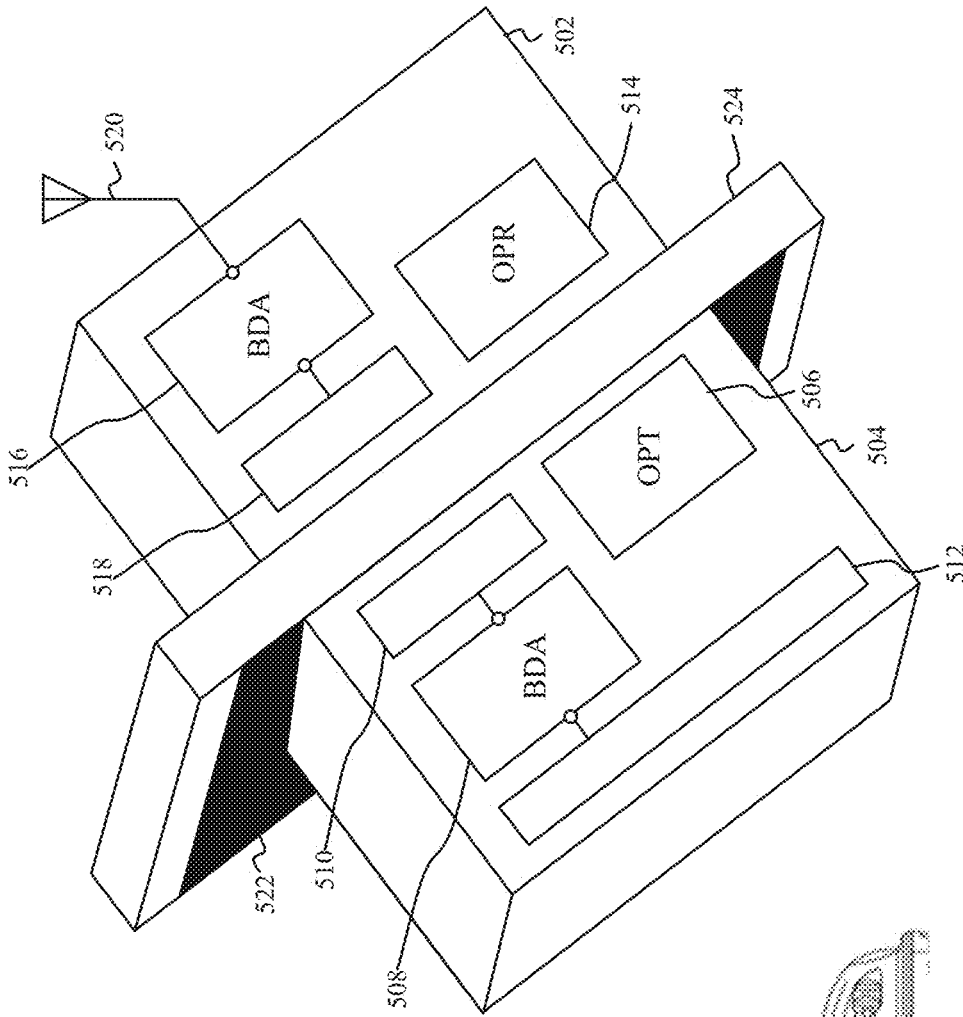

FIG. 5C

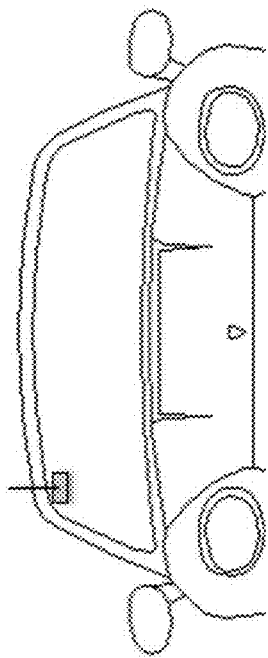

FIG. 5A

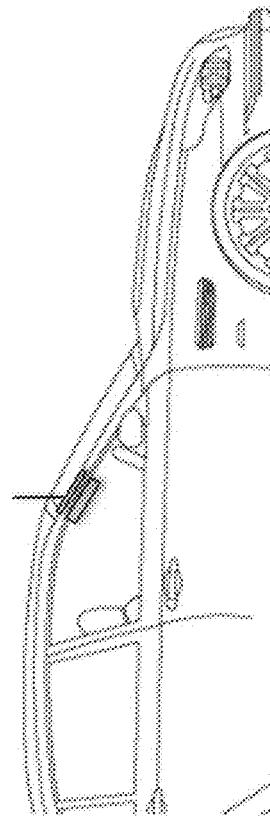

FIG. 5B

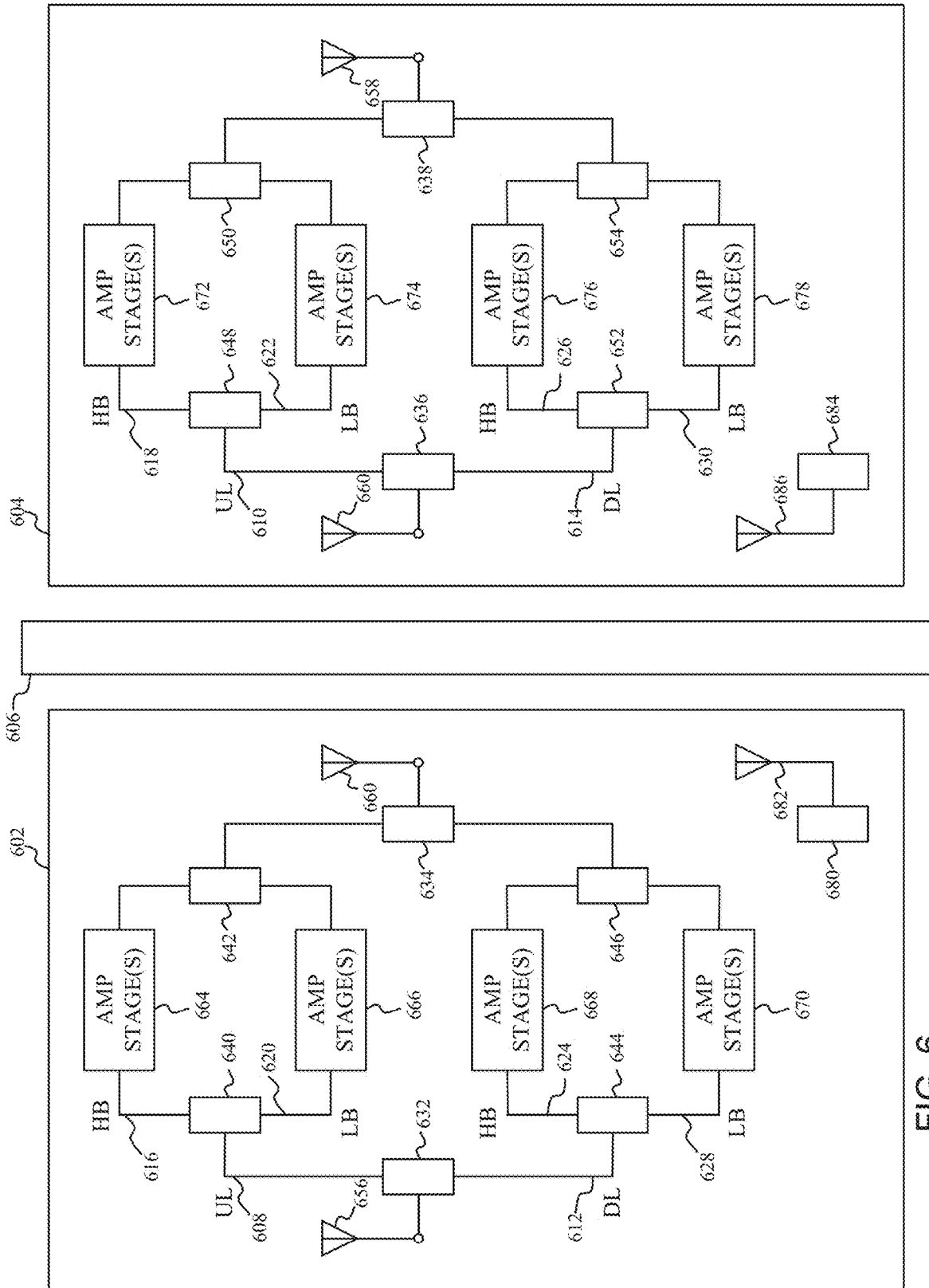

FIG. 6

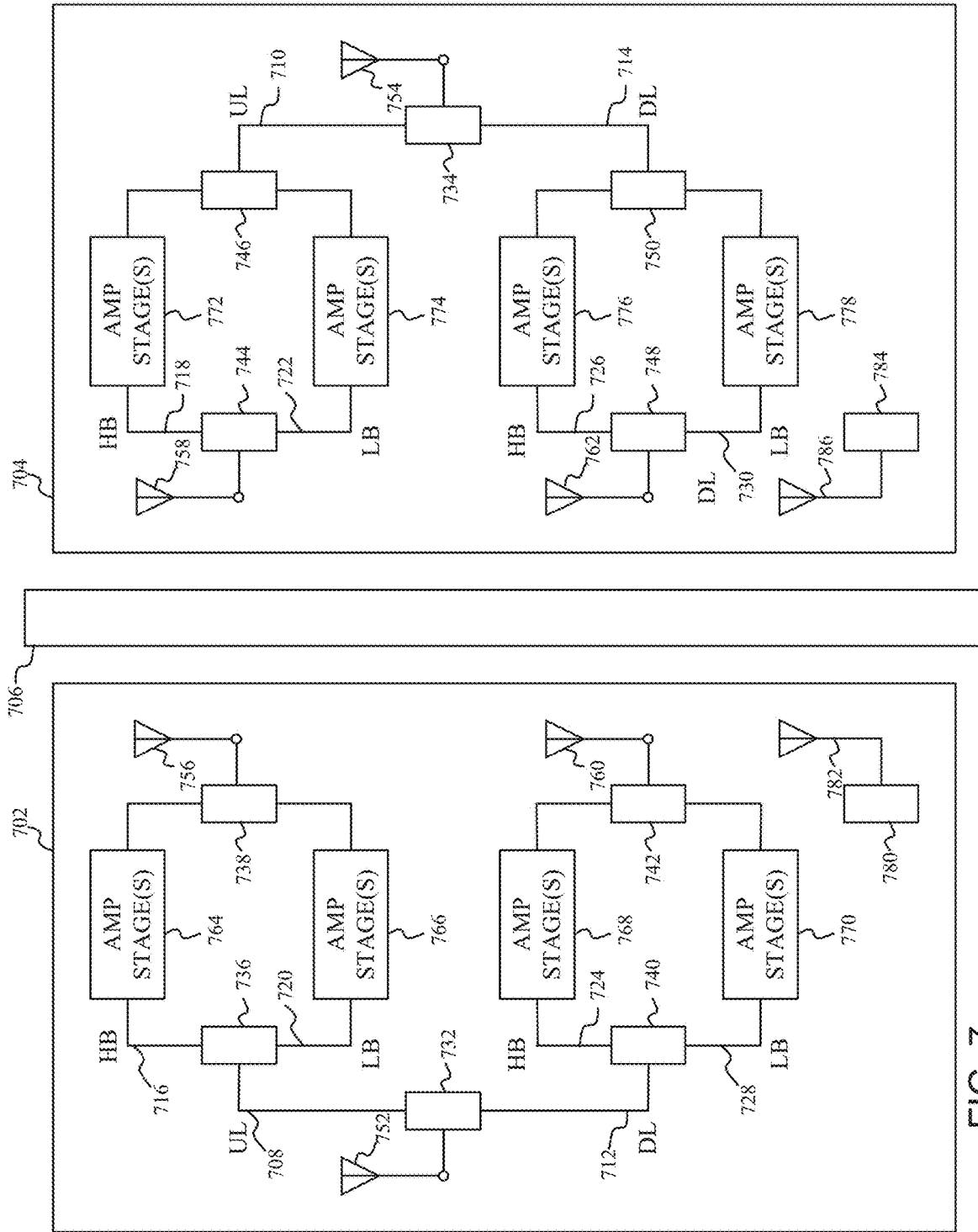

FIG. 7

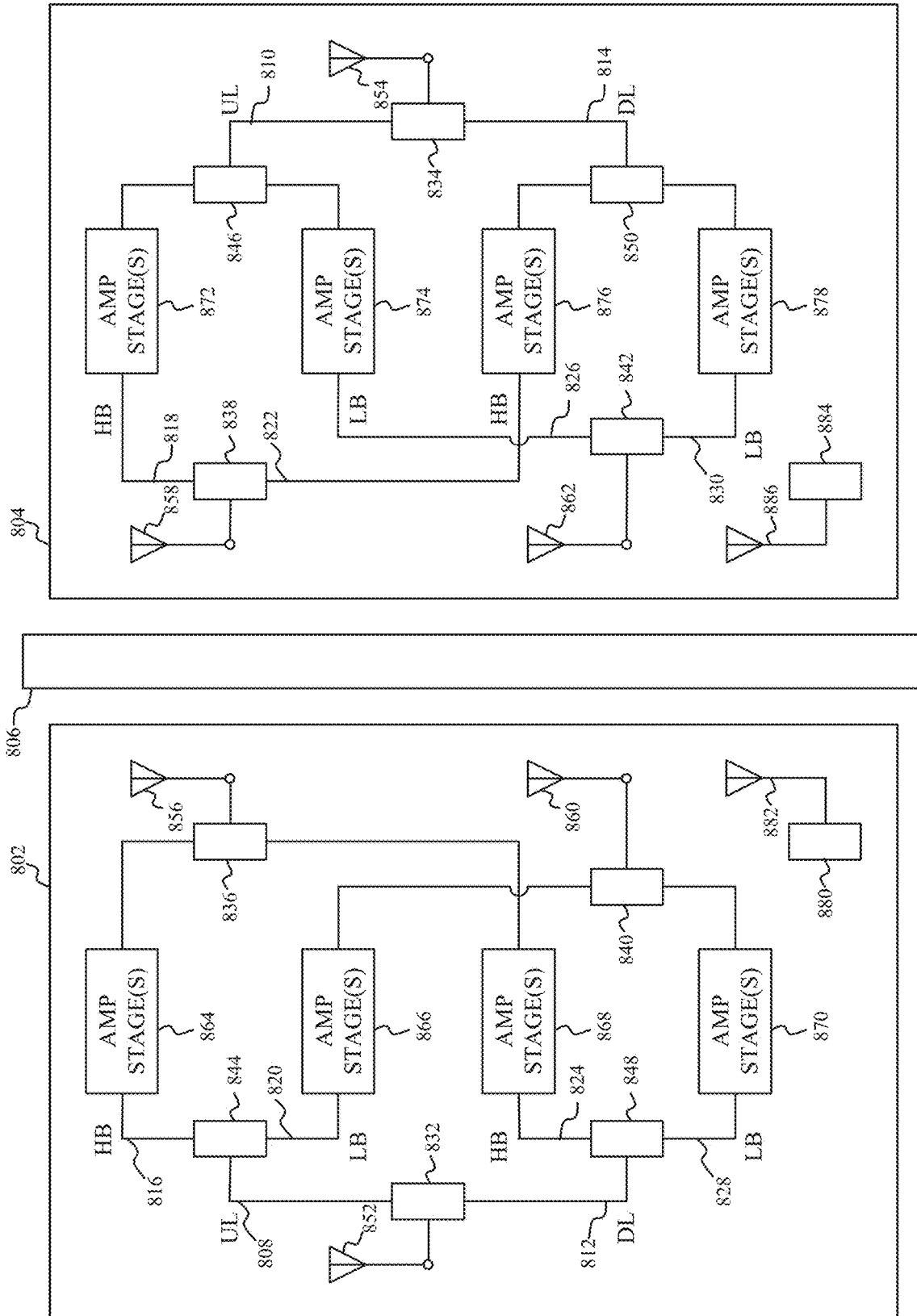

FIG. 8

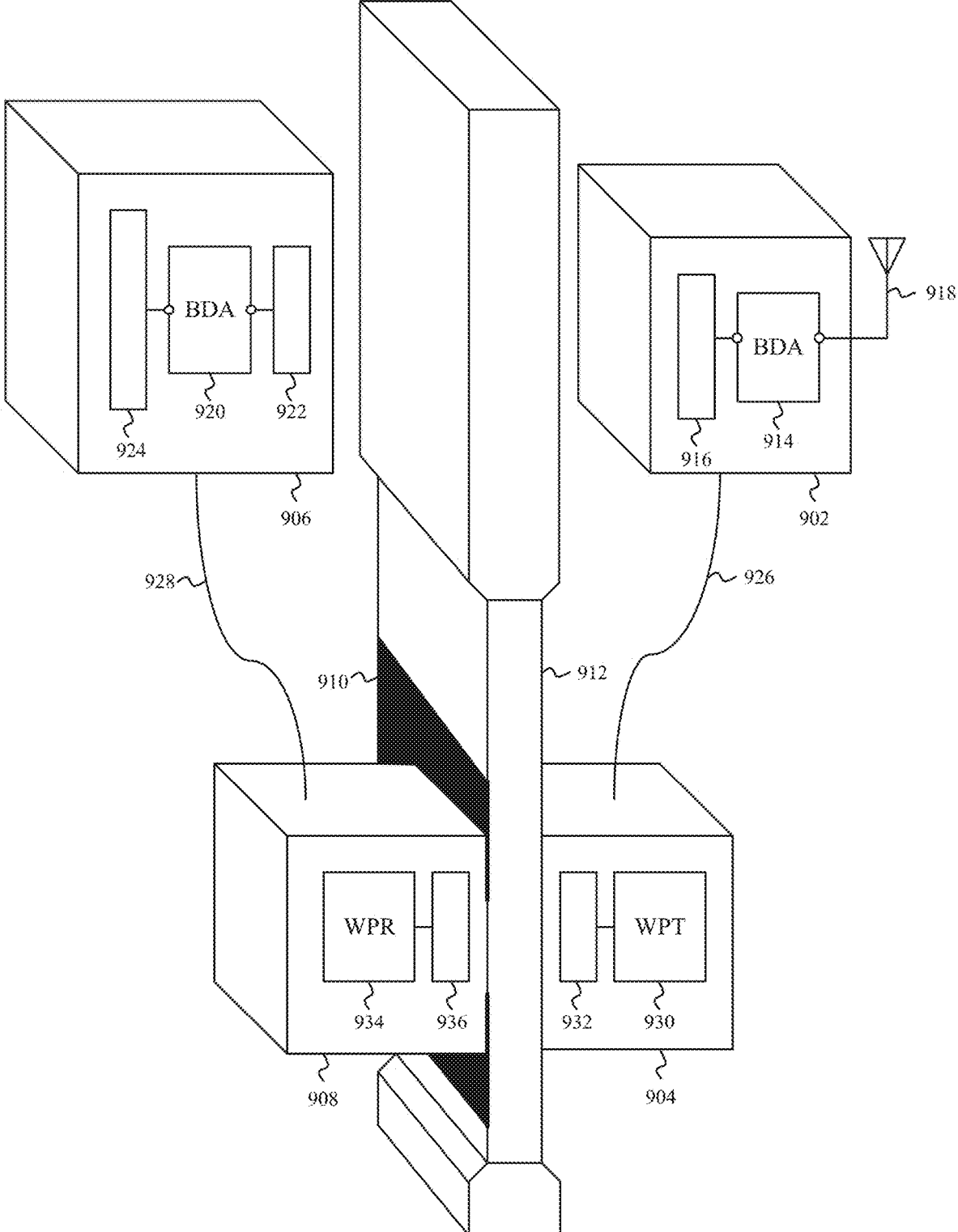

FIG. 9

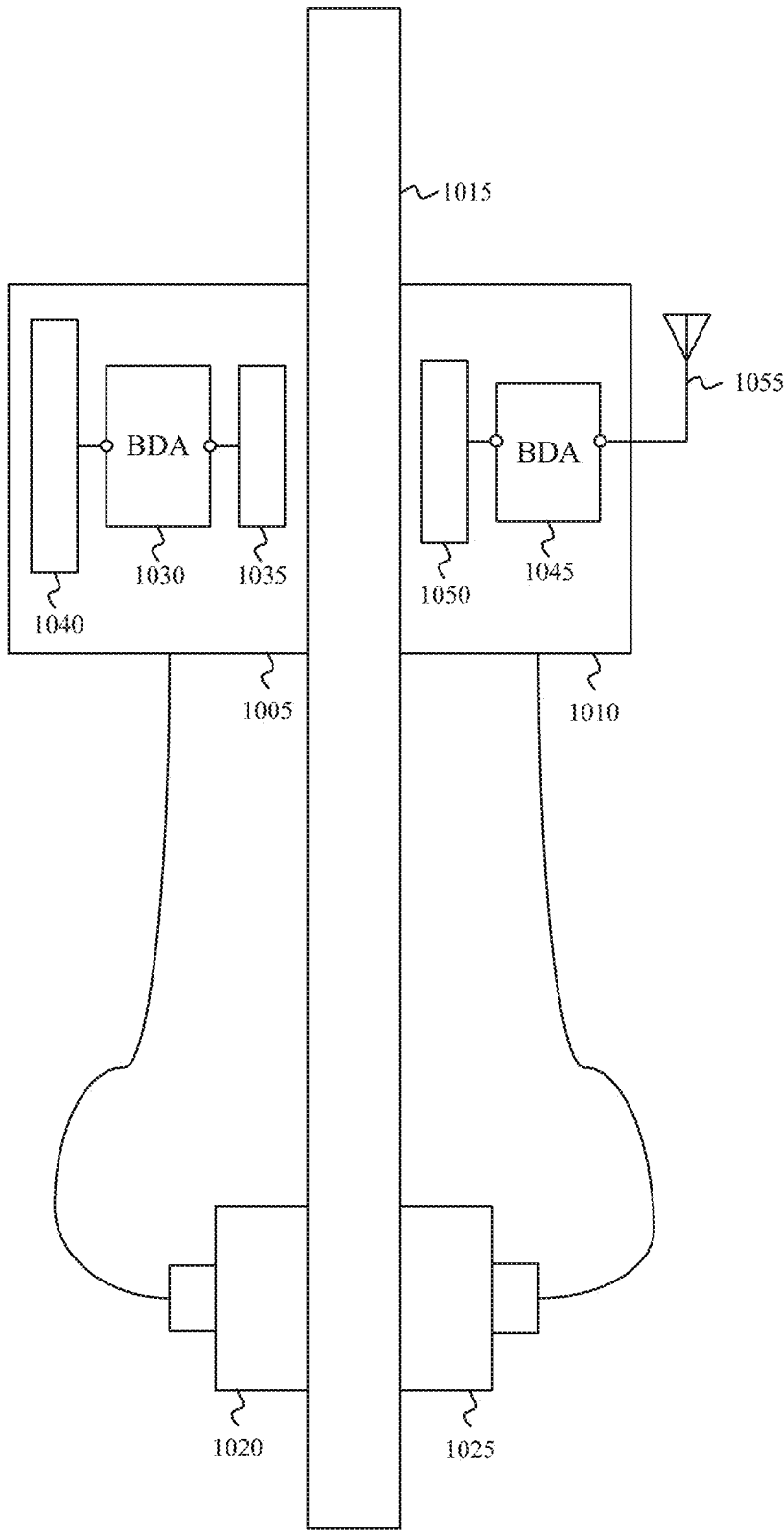

FIG. 10

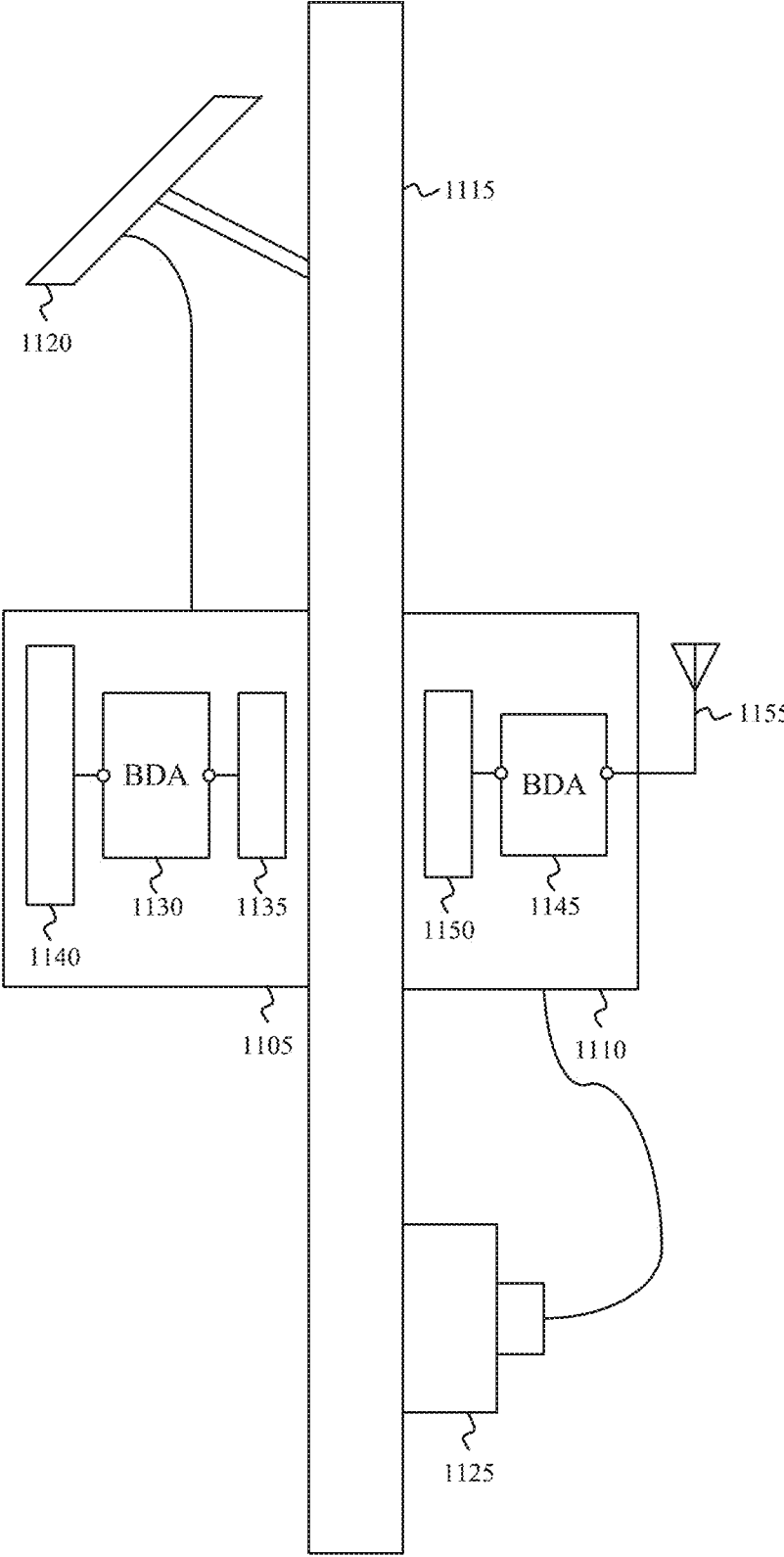

FIG. 11

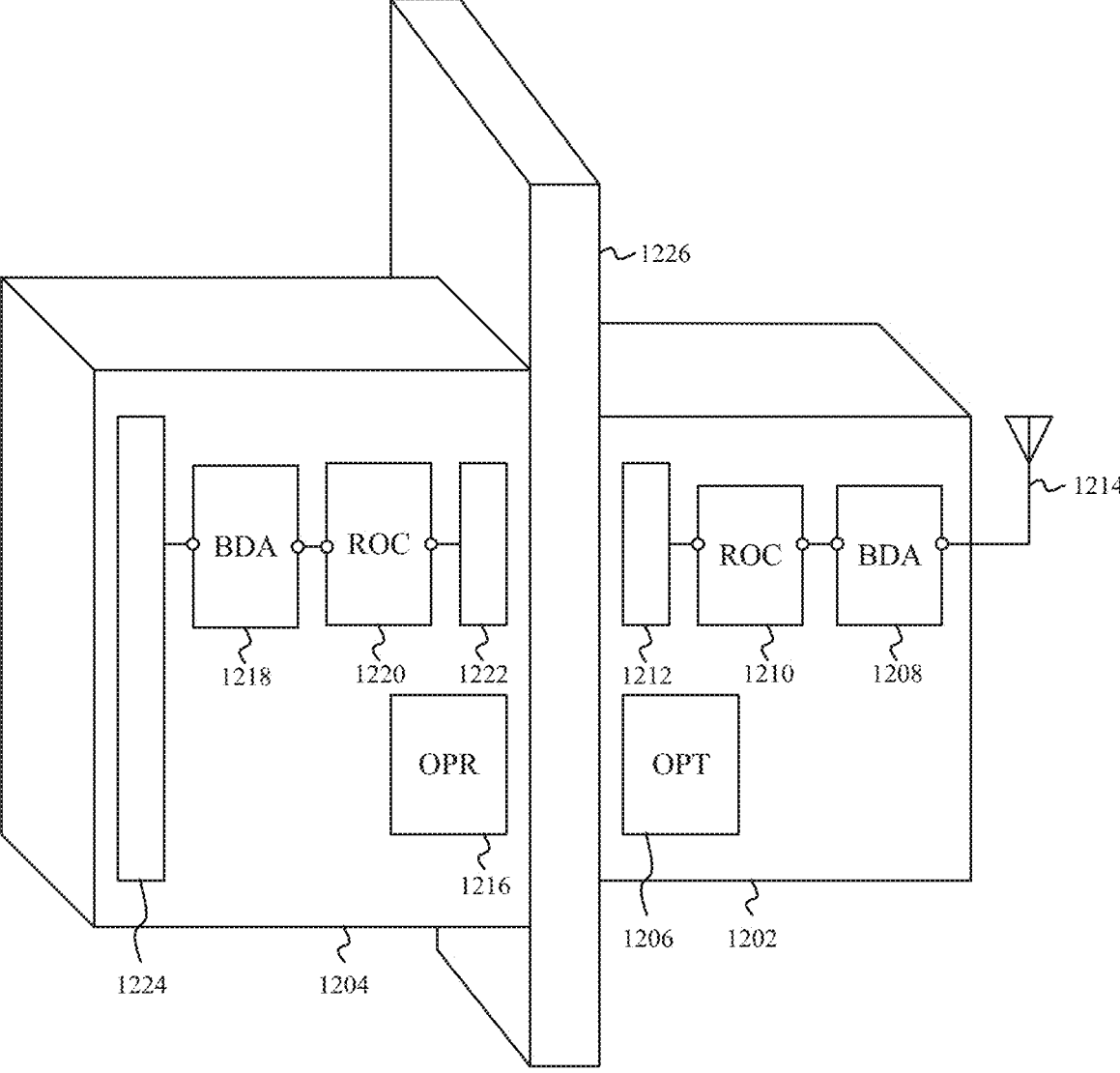

FIG. 12

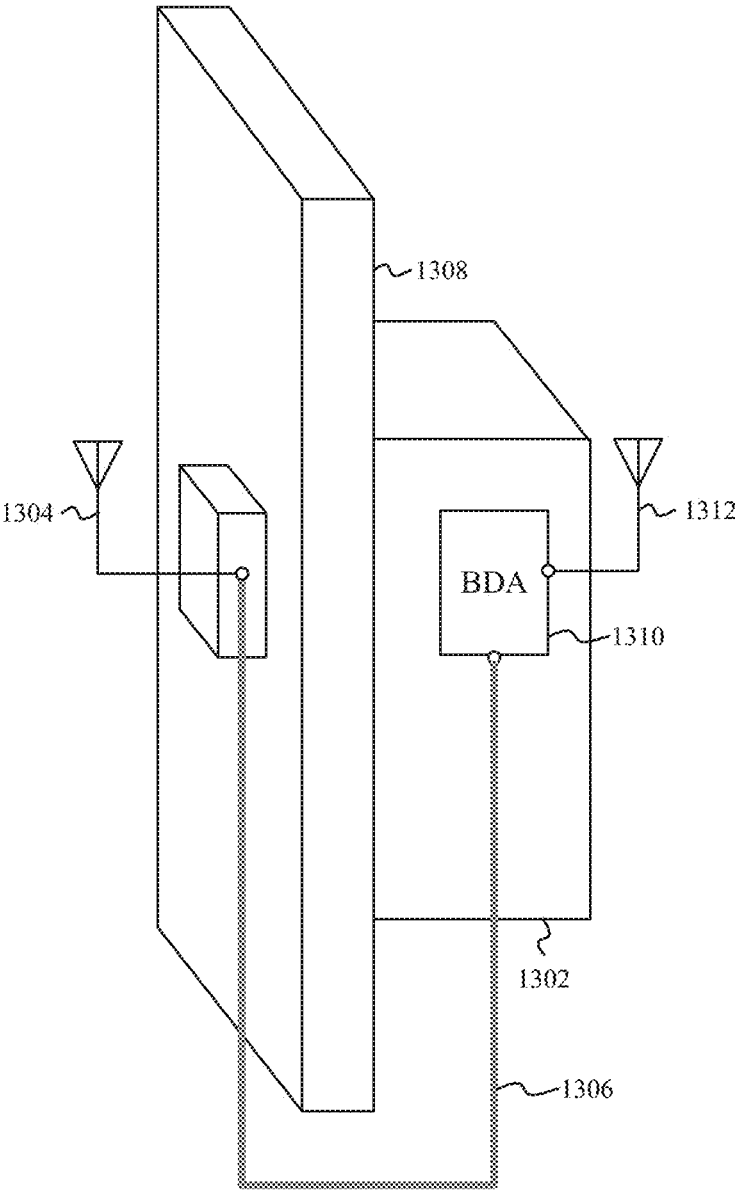

FIG. 13

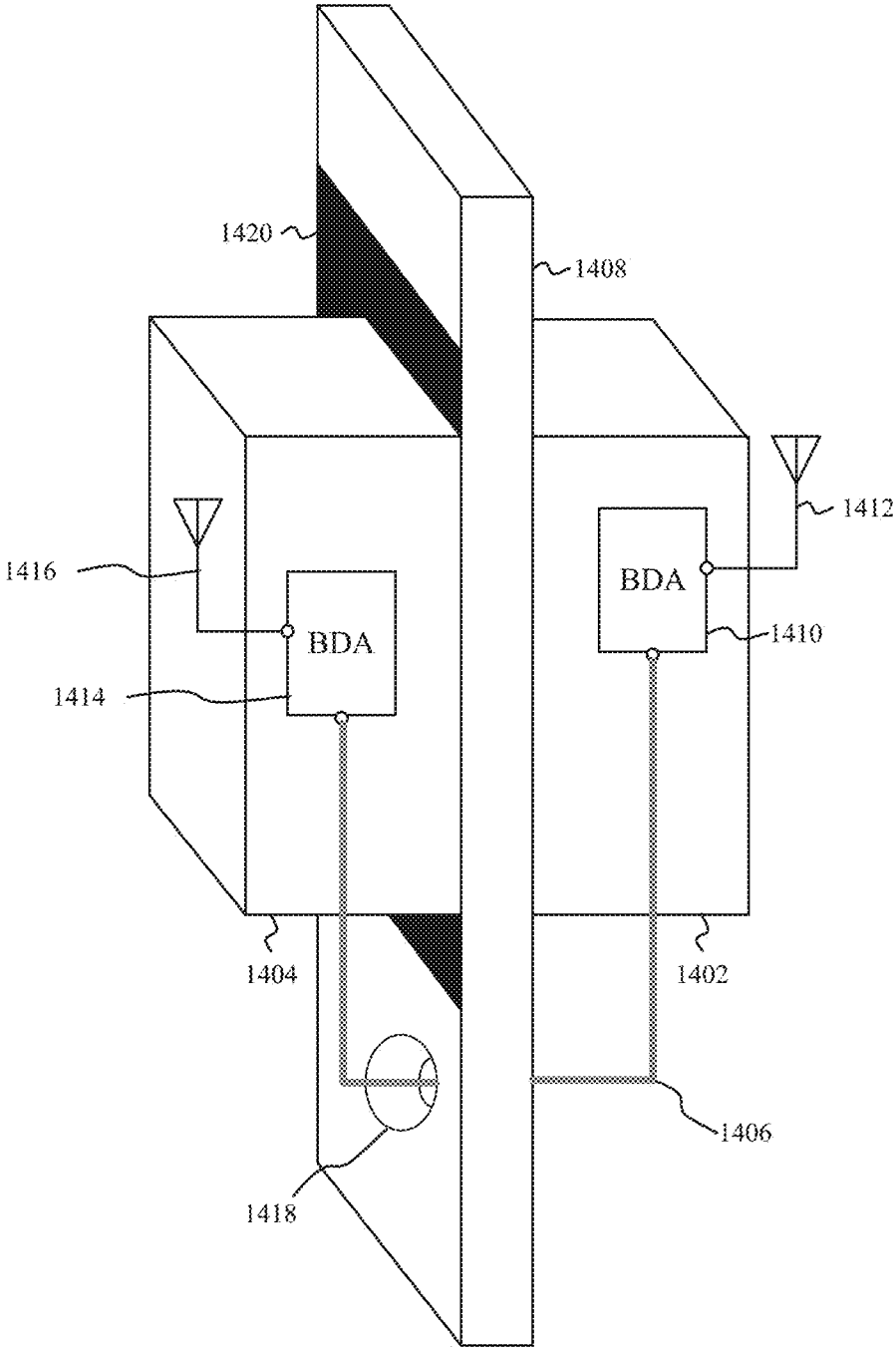

FIG. 14

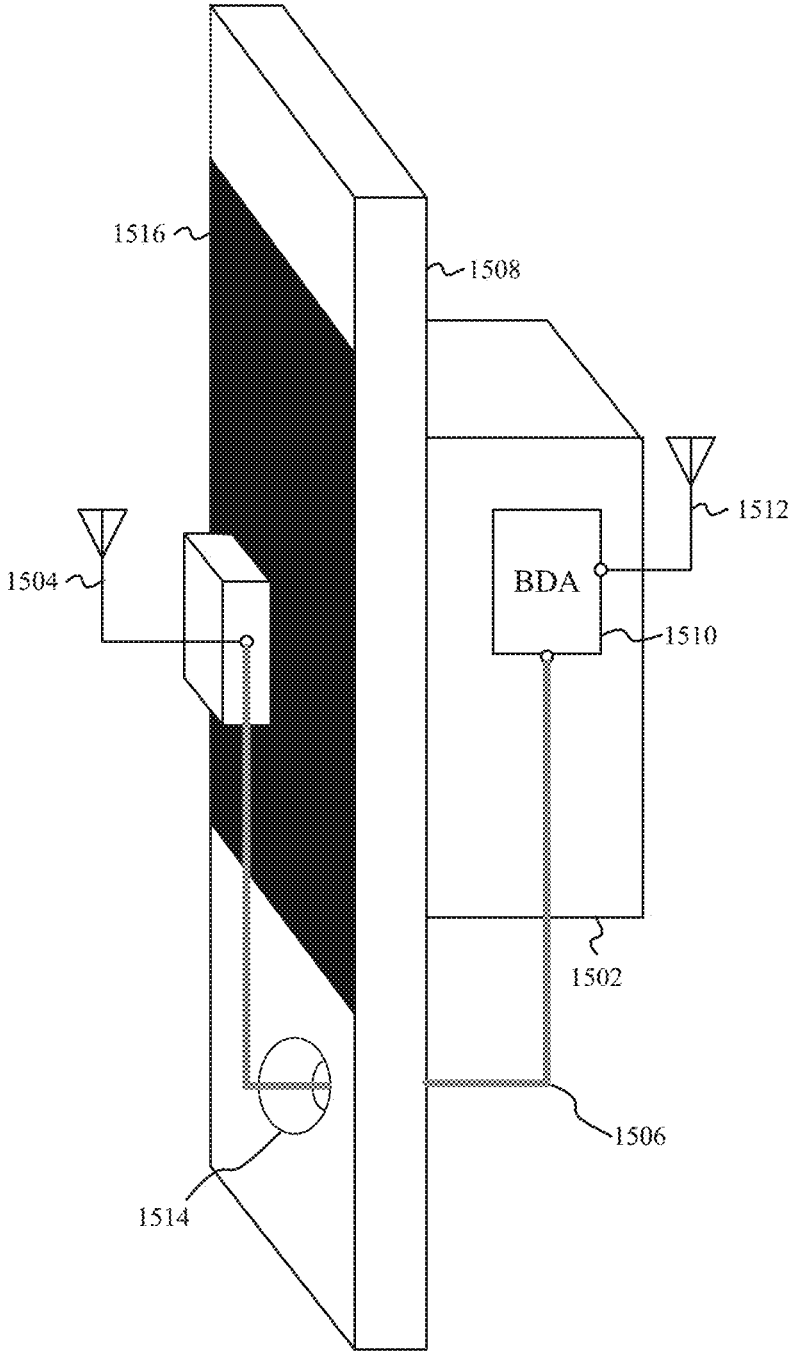

FIG. 15

MULTI-AMPLIFIER REPEATER SYSTEM FOR WIRELESS COMMUNICATION

RELATED APPLICATIONS

[0001] The present application is a continuation of U.S. patent application Ser. No. 15/947,684 filed Apr. 6, 2018 with a docket number of 3969-106.NP which claims the benefit of U.S. Provisional Patent Application No. 62/482,828 filed Apr. 7, 2017 with a docket number of 106.PROV.US, the entire specifications of which are hereby incorporated by reference in their entirety for all purposes.

BACKGROUND

[0002] Wireless communication systems, such as cellular telephone systems, have become common throughout the world. A wireless repeater or booster is a radio frequency (RF) device used to amplify wireless communication signals in both uplink and downlink communication channels, as illustrated in FIG. 1. The uplink channel is generally referred to as the direction from one or more user equipment (UE) **110** to a base station (BS) **120**. The downlink channel is generally referred to as the direction from the base station **120** to the user equipment **110**. For a wireless telephone system, the base station **120** may be a cell tower, and the user equipment **110** may be one or more smart phones, tablet, laptop and desktop computers, multimedia devices such as a television or gaming system, cellular internet of things (CloT) devices, or other types of computing devices. The repeater **130** typically includes a signal amplifier **140** coupled between two antennas, a user-side antenna **150** and a service-side antenna **160**. The user equipment **110** may be operating within a structure, while the repeater **130** may be located inside or outside the structure **170**. The structure **170** may introduce signal losses that deleteriously affect the user equipment **110** and/or the repeater **130**. In addition, constraints imposed by government agencies, industry standards, or similar regulatory entities may limit the amount of amplification (gain), the maximum output power, the output noise, and other parameters associated with the operation of the repeater **130**. Therefore, there is a continuing need for improved wireless repeaters.

DESCRIPTION OF THE DRAWINGS

[0003] Features and advantages of the disclosure will be apparent from the detailed description which follows, taken in conjunction with the accompanying drawings, which together illustrate, by way of example, features of the disclosure; and, wherein:

[0004] FIG. 1 depicts a wireless system, in accordance with an example;

[0005] FIGS. 2A and 2B depict a wireless system, in accordance with an example;

[0006] FIGS. 3A-3C depict a wireless system, in accordance with another example;

[0007] FIGS. 4A and 4B depict a wireless system, in accordance with yet another example;

[0008] FIGS. 5A-5C depict a wireless system, in accordance with yet another example;

[0009] FIG. 6 depicts a wireless system, in accordance with yet another example;

[0010] FIG. 7 depicts a wireless system, in accordance with yet another example;

[0011] FIG. 8 depicts a wireless system, in accordance with yet another example;

[0012] FIG. 9 depicts a wireless system, in accordance with yet another example;

[0013] FIG. 10 depicts a wireless system, in accordance with yet another example;

[0014] FIG. 11 depicts a wireless system, in accordance with yet another example;

[0015] FIG. 12 depicts a wireless system, in accordance with yet another example;

[0016] FIG. 13 depicts a wireless system, in accordance with yet another example;

[0017] FIG. 14 depicts a wireless system, in accordance with yet another example; and

[0018] FIG. 15 depicts a wireless system, in accordance with yet another example.

[0019] Reference will now be made to the exemplary embodiments illustrated, and specific language will be used herein to describe the same. It will nevertheless be understood that no limitation of the scope of the technology is thereby intended.

DETAILED DESCRIPTION OF THE INVENTION

[0020] Before the present technology is disclosed and described, it is to be understood that this technology is not limited to the particular structures, process actions, or materials disclosed herein, but is extended to equivalents thereof as would be recognized by those ordinarily skilled in the relevant arts. It should also be understood that terminology employed herein is used for the purpose of describing particular examples only and is not intended to be limiting. The same reference numerals in different drawings represent the same element. Numbers provided in flow charts and processes are provided for clarity in illustrating actions and operations and do not necessarily indicate a particular order or sequence.

[0021] An initial overview of technology embodiments is provided below and then specific technology embodiments are described in further detail later. This initial summary is intended to aid readers in understanding the technology more quickly but is not intended to identify key features or essential features of the technology nor is it intended to limit the scope of the claimed subject matter.

[0022] In one aspect, a multi-repeater system may include first and second repeaters configured to automatically receive, amplify and retransmit on a bi-directional basis the signals received from base, fixed, mobile, or portable stations, with no change in frequency or authorized bandwidth. The repeaters can provide improved wireless coverage within a limited area such as a home, car, boat or recreational vehicle (RV). The repeaters can operate on the frequencies and in the market areas of a specified licensee service provider, or on the frequencies or in the market areas of multiple licensee service providers. The repeaters can operate in a fixed location, such as a house or building, or in a moving vehicle such as a car or boat.

[0023] In one aspect, the first and second repeaters can include respective first and second wireless power units. In one aspect, the first wireless power unit includes a wireless power transmitter and a first power coupler, and the second wireless power unit includes a wireless power receiver and a second power coupler. The wireless power transmitter can be configured to convert a portion of DC or AC electrical

power received from a power source to a RF power signal. The first power coupler can be configured to transmit the RF power signal through a structural element to the second power coupler. The wireless power receiver can be configured to convert the received RF power signal to DC or AC electrical power. The second repeater can be configured to be powered by the DC or AC electrical power from the wireless power receiver.

[0024] In another aspect, the first wireless power unit can include an optical power transmitter and the second wireless power unit can include an optical power receiver. The

amplify one or more RF communication signals. In one instance, the RF communication signals can be cellular telephone RF signals, such as a Third-Generation Partnership Project (3GPP) Long Term Evolved (LTE) signals. In one instance, the one or more bi-direction amplifier **214** can be configured to amplify both uplink and downlink 3GPP LTE signals of one or more carrier bands. In one instance, the uplink 3GPP LTE signals may operate at a first frequency band and the downlink 3GPP LTE signal may operate at a second frequency band. In one instance the operating bands of the RF communication signals may include:

TABLE 1

Bands of Operation						
Uplink			Downlink			
Band	Fmin (MHz)	Fmax (MHz)	Fc (MHz)	Fmin (MHz)	Fmax (MHz)	Fc (MHz)
II	1850.0-1910.0		1880.0	1930.0-1990.0		1960.0
IV	1710.0-1755.0		1732.5	2110.0-2155.0		2132.5
V	824.0-849.0		836.5	869.0-894.0		881.5
XII	699.0-716.0		707.5	729.0-746.0		737.5
XIII	776.0-787.0		781.5	746.0-757.0		751.5

optical power transmitter can be configured to convert a portion of DC or AC electrical power received from a power source to an optical signal and transmit the optical signal through a structural element. The optical power receiver can be configured to receive the optical signal and convert the optical signal to the DC or AC electrical power. The second repeater can be configured to be powered by DC or AC electrical power from the optical power receiver.

[0025] FIGS. 2A and 2B depict a wireless system, in accordance with an example. In one aspect, the wireless system includes a first repeater **202** and a second repeater **204**. The first and second repeaters **202**, **204** are adapted for disposition opposite each other about a structural element **206**, such as a wall, window or similar element. In one instance, the first repeater **202** can be an inside repeater adapted for placement within a structure, and the second repeater **204** can be an outside repeater adapted for placement outside the structure. The first repeater **202** may also be referred to as a device/client repeater, subscriber side repeater or service side repeater, while the second repeater **204** may also be referred to as a wireless network repeater, provider side repeater or donor side repeater. In one aspect, the various functions of the repeaters **202**, **204**, can be implemented in hardware, firmware, software stored in memory and executed by one or more processing units, and/or any combination thereof.

[0026] In one aspect, the first repeater **202** can include a wireless power transmitter (WPT) **210**, a power coupler **212**, one or more bi-directional amplifiers (BDA) **214**, a RF coupling antenna **216**, and one or more optional transmission antennas **218**. In one aspect, the second repeater **204** can include a wireless power receiver (WPR) **224**, a power coupler **226**, one or more bi-directional amplifiers (BDA) **228**, one or more RF coupling antennas **230**, and one or more optional transmission antennas **232**. The wireless system may optionally include one or more conductive films **208** for disposition between the first and second repeaters **202**, **204**.

[0027] In one aspect, the one or more bi-directional amplifiers **214** of the first repeater **202** can be configured to

[0028] In one aspect, the one or more transmission antennas **218** can be integral to the first repeater **214** (e.g., internal or directly coupled external transmission antenna). Alternatively, the one or more transmission antennas **218** may be separate from the first repeater **202**, but removably coupled to the bi-directional amplifier **214** (e.g., remote external transmission antenna), optionally by one or more wired communication links (e.g., coaxial cable). The transmission antennas **218** may be a directional antenna or an omnidirectional antenna.

[0029] In one aspect, the one or more bi-directional amplifiers **214** of the first repeater **202** can include one or more RF transmission ports **220** and one or more RF coupling ports **222**. The one or more transmission antennas **218** can be coupled to the respective one or more RF transmission ports **220**, and the one or more RF coupling antennas **216** can be coupled to the respective one or more RF coupling ports **222** of the one or more bi-directional amplifiers **214** of the first repeater **202**.

[0030] In one aspect, the one or more bi-directional amplifiers **228** of the second repeater **204** can be configured to amplify one or more RF communication signals. In one instance, the one or more bi-direction amplifiers **228** can be configured to amplify both uplink and downlink 3GPP LTE signals.

[0031] In one aspect, the one or more transmission antennas **232** can be integral to the second repeater **204** (e.g., internal or directly coupled external transmission antenna). Alternatively, the one or more transmission antennas **232** may be separate from the second repeater **204**, but coupled to the bi-directional amplifier **228** (e.g., remote external transmission antenna), optionally by one or more wired communication links (e.g., coaxial cable). The transmission antennas **232** may be a directional antenna or an omnidirectional antenna.

[0032] In one aspect, the bi-directional amplifier **228** can include one or more RF transmission port **234** and one or more RF coupling ports **236**. The one or more transmission antennas **232** can be coupled to the respective one or more

RF transmission ports 234, and the one or more power couplers 226 can be coupled to the respective one or more RF coupling ports 236 of the bi-directional amplifier 228 of the second repeater 204.

[0033] In one aspect, the bi-directional amplifier 228 of the second repeater can boost one or more RF communication signal received from and transmitted to a Base Station (BS) (e.g., service provider cellphone tower). The base station can be a node of a mobile phone network, such as a 3GPP LTE evolved NodeB (eNB). In one aspect, the second repeater 204 and the one or more transmission antennas 232 set the noise figure and increase performance. The bi-directional amplifier 228 can improve the gain and/or noise-power on uplink and/or downlink communication RF signals, at the RF transmission port 236 of the bi-directional amplifier 228, to increase the range and/or increase the signal strength of RF communication signal between the second repeater 204 and the base station of a service provider. On the downlink path the second repeater 204 can preserve the signal-to-noise ratio and can set the noise figure for the system at a much lower level than otherwise. On the uplink, the second repeater 204 enables a much stronger signal to be transmitted and therefore reach the base station in more cases. In some instances, the gain or noise power as measured at the RF transmission port 234 or transmission antenna 232 of the second repeater 204 can be constrained by a government agency, an industry standard, or similar regulatory entity. Accordingly, the bi-directional amplifier 228 of the second repeater 204 can be configured to provide a gain or noise power level as measured at the RF transmission port 234 or transmission antenna 232 of the second repeater 204 to comply with such constraints. In one aspect, the bi-directional amplifier 228 can be configured to control the uplink and downlink power supplied by the bi-directional amplifier 228 independently.

[0034] In one aspect, the structural element 206, such as a wall, door, window or similar element can appreciably reduce the signal strength of RF signals entering a structure such as a home, office building, or car. Therefore, in one aspect, the bi-directional amplifier 214 of the first repeater 202 and/or the bi-directional amplifier 228 of the second repeater 204 can boost the one or more RF communication signals transmitted through the structural element 206. The bi-directional amplifier 214 of the first repeater 202 and/or the bi-directional amplifier 228 of the second repeater 204 can improve the gain and/or noise power on uplink and/or downlink communication RF signals, at the RF coupling port 222 of the bi-directional amplifier 214 and/or at the RF coupling port 236 of the bi-directional amplifier 228, to compensate for the loss through the structural element 206 which can exceed 20-30 dB. The gain or noise power of at the RF coupling port 222 of the bi-directional amplifier 214 and/or at the RF coupling port 236 of the bi-directional amplifier 228 can be selected such that the losses introduced by the structural element 206 reduces feedback through the one or more transmission antennas 218 of the first repeater 202 and/or the transmission antenna 232 of the second repeater 204.

[0035] In one aspect, the bi-directional amplifier 214 of the first repeater 202 can transmit the RF communication signals, with little or no boost, to one or more User Equipment (UE) within the structure. Optionally, the bi-directional amplifier 214 of the first repeater 202 can boost the one or more RF communication signals for transmission to the one

or more UEs. The UEs can include smart phones, tablet computing devices, laptop computers, multimedia devices such as televisions or gaming systems, internet of things (TOT) devices, or other types of computing devices that are configured to provide text, voice, data, or other types of digital or analog communication over wireless communication. The bi-directional amplifier 214 can improve the gain and/or noise power on uplink and/or downlink communication RF signals, at the RF transmission port 220 of the bi-directional amplifier 214, to increase the range and/or increase the signal strength of RF communication signal between the first repeater 202 and one or more UEs within the structure. In some instances, the gain or noise power as measured at the RF transmission port 220 or transmission antenna 218 of the first repeater 202 can be constrained by a government agency, an industry standard, or similar regulatory entity. Accordingly, the bi-directional amplifier 214 of the first repeater 202 can be configured to provide a gain or noise power level as measured at the RF transmission port 220 or transmission antenna 218 of the first repeater 202 to comply with such constraints. In one aspect, the bi-directional amplifier 214 can be configured to control the uplink and downlink power supplied by the bi-directional amplifier 214 independently.

[0036] In one instance, the bi-directional amplifier 228 of the second repeater 204 can provide approximately 30-40 dB of gain. In addition, the one or more transmission antennas 232 of the second repeater 204 can be an antenna integral to the second repeater 204. The integral antenna can be a directional panel antenna. The bi-directional amplifier 214 of the first repeater can provide approximately 50-60 dB of gain. In addition, the transmission antenna of the first repeater 202 can be an external antenna coupled to the first repeater 202 by a wired communication link 240. A directional transmission antenna 232 can be placed on the structure 206 pointing toward the base station of the service provider to improve the transmission and reception of the RF communication signal by the second repeater 204. In addition, a directional transmission antenna 232 can be pointed away from the first repeater 202 to reduce the feedback between the transmission antennas 218, 232, between the coupling antenna 216 of the first repeater and the transmission antenna 232 of the second repeater, and/or between the coupling antenna 230 of the second repeater 204 and the transmission antenna 218 of the first repeater 202. In addition, by placing the transmission antenna 218 coupled to the first repeater 202 spaced apart from the first repeater 202 (e.g., in another room of a house or office building) feedback between the transmission antennas 218, 232, between the coupling antenna 216 of the first repeater and the transmission antenna 232 of the second repeater, and/or between the coupling antenna 230 of the second repeater 204 and the transmission antenna 218 of the first repeater 202 can be reduced.

[0037] In another instance, the bi-directional amplifier 228 of the second repeater 204 can provide approximately 30-50 dB of gain, and the bi-directional amplifier 214 of the first repeater can provide approximately 30-50 dB of gain. In addition, the transmission antennas 218, 232 of the first and second repeaters 202, 204 can be integral antennas. The integral antennas can both be directional antennas that can reduce the feedback between the transmission antennas 218, 232, between the coupling antenna 216 of the first repeater and the transmission antenna 232 of the second repeater,

and/or between the coupling antenna 230 of the second repeater 204 and the transmission antenna 218 of the first repeater 202.

[0038] In yet another instance, the bi-directional amplifier 228 of the second repeater 204 can provide approximately 30-40 dB of gain. In addition, the one or more transmission antennas 232 of the second repeater 204 can be an antenna integral to the second repeater 204. The integral antenna can be a directional panel antenna. The bi-directional amplifier 214 of the first repeater 202 can provide approximately 50-60 dB of gain. In addition, bi-directional amplifier 214 of the first repeater 202 can be coupled to a third repeater 238 by a wired RF communication link 240. The third repeater 238 can provide an additional 30-50 dB of gain. The gain of the first repeater 202 and/or third repeater 238 can also compensate for transmission loss across the wired RF communication link 240.

[0039] In one aspect, the amount of gain provided by the first repeater 202 and/or the second repeater 204 can be based upon the transmission loss across the structural element 206. In one aspect, the first and second repeater 202, 204 can use Radio Frequency (RF) reference signals or RF communication signals to determine the transmission loss across the structural element 206 coupling the repeaters. In one aspect, the second repeater 204 can further include a signal generator. The first repeater 202 can further include a transmission loss detector and a gain controller. The signal generator of the second repeater 204 can generate RF reference signals at a predetermined amplitude or power for transmission across the structural element 206 to the first repeater 202. The transmission loss detector of the first repeater 202 determines a transmission loss across the structural element 206 based on the amplitude or power of the received RF reference signals. The gain controller of the first repeater 202 can adjust a gain or noise power of the amplifier of one or both of the repeaters 202, 204 to compensate for the determined transmission loss across the structural element 206. The RF reference signals can advantageously be used to calibrate one or both of the amplifiers, while the repeaters can continuously amplify the RF communication signals.

[0040] In another aspect, the second repeater 204 can further include a signal detector. The first repeater 202 can further include a transmission loss detector and a gain controller. The signal detector of the second repeater 204 can determine the amplitude or power of the RF communication signals as received at the second repeater 204. The transmission loss detector of the first repeater 202 can determine the transmission loss across the structural element 206 based upon the amplitude or power of the RF communication signals as received at the second repeater 204 and the first repeater 202. The gain controller of the first repeater 202 can adjust the gain or noise power of one or both of the repeaters 202, 204 to compensate for the determined transmission loss across the structural element 206. The RF communication signals can again be used advantageously to calibrate one or both of the amplifiers, while the repeaters can continuously amplify the RF communication signals.

[0041] In one aspect, the wireless power transmitter 210 and the power coupler 212 of the first repeater 202 make up a first wireless power unit, and the wireless power receiver 224 and the power coupler 226 of the second repeater 202 make up a second wireless power unit. The wireless power transmitter 210 of the first repeater 202 can be coupled to the

power coupler 212. In one aspect, the wireless power receiver 224 of the second repeater 204 can be coupled to the power coupler 226. In one aspect, the power couplers 212, 226 of the first and second repeaters 202, 204 can be inductive coils for non-radiative techniques using magnetic fields. In another aspect, the power couplers 212, 226 of the first and second repeaters 202, 204 can be capacitive electrodes for radiative techniques using electric fields.

[0042] In one aspect, the wireless power transmitter 210 can convert a portion of Direct Current (DC) or Alternating Current (AC) electrical power received from a power source of the first repeater 202 to wireless power. The term wireless power is used herein as a generic term that refers to a number of different power transmission technologies that use time-varying electric, magnetic, or electromagnetic fields, or photon energy. In one aspect, the DC or AC power can be converted to a RF power signal. The RF power signal can be transmitted from the power coupler 212 of the first repeater 202 through the structural element 206 and received by the power coupler 226 of the second repeater 204. A first shielding path can be between the power coupler 212 of the first repeater 202 and the structural element 206. A second shielding path can be between the power coupler 226 of the second repeater 204 and the structural element 206. The first or second shielding path can substantially limit electromagnetic waves passing through the one or more openings in the conductive film to the electromagnetic signal or photon energy associated with the wireless power transfer. The use of the openings in the conductive films, combined with the shielding paths, enables an increased efficiency in passing the wireless power between the first and second repeaters, while maintaining an increased isolation between the transmission antennas of the first and second repeaters due to the conductive film. In one example, the shielding path can be comprised of a material that substantially blocks electromagnetic waves. For example, an opaque metallic tape can be used to form the first shielding path or the second shielding path. The first or second shielding path can be shaped based on the beam shape formed by the power coupler 212 of the first repeater 202 or the power coupler 226 of the second repeater 204. The wireless power receiver 224 can convert the RF power signal received by the power coupler 226 into DC or AC electrical power. The DC or AC electrical power from the wireless power receiver 224 can power the second repeater 204. In one instance, the wireless power transmitter 210 can transmit power to the wireless power receiver 224 to enable generation of approximately 500 mA of steady state current, 1000 mA of peak current draw, and approximately 5-7.5 W of total power for use by the circuits of the second repeater 204.

[0043] As discussed above, the bi-directional amplifier 228 of the second repeater 204 can be configured to control the uplink and downlink power supplied by the bi-directional amplifier 228 independently. In one aspect, the power supplied by the bi-directional amplifier 228 can be configured to provide respective power levels for the uplink and downlink signal transmission within applicable limits that may be set by one or more regulatory entities. In other aspects, it is to be appreciated that the uplink transmission power level typically is greater than the downlink transmission power level. In addition, the size of the wireless power transmitter 210, wireless power receiver 224 and power couplers 212, 226 tend to increase as the amount of power needed by the second repeater 204 increases. Therefore, the

bi-directional amplifier **228** of the second repeater **204** can be operated in a passive mode, whereby the bi-directional amplifier **228** supplies little or no additional power during transmission of uplink signals.

[0044] In one aspect, the wireless power transfer between the first and second repeaters **202**, **204** provided by the powerless power transmitter **210**, wireless power receiver **224** and power couplers **212**, **226** enable easy installation of the second repeater **204** on the outside of the structure. Installation can be simplified because one or more cables coupling the first and second repeaters **202**, **204** are not used, and therefore do not need to be routed through or around structural elements such as walls, windows, or doors. Eliminating the need to route cables coupling the first and second repeaters **202**, **204**, provided by the present technology, may be particularly advantageous for consumers doing their own installation, and/or deployment in structures that may be rented or leased such as apartments or leased cars. The outside second repeater **204** of the present technology also advantageously sets the noise figure and increases performance as compared to a single inside repeater or locating both the first and second repeaters inside a structure.

[0045] In one aspect, the one or more conductive films **208** can be transparent films or substantially transparent films. A conductive film **208** can be substantially transparent when it has a visible light transmittance of 70% or more. In one instance, the transparent conductive films may be a film of thin metal wires or other types of metallic coating that can be used to reflect desired wavelengths. Window coatings and films typically are designed to reflect ultraviolet (UV) wavelengths and infrared (IR) wavelengths. However, the same coatings and films can also substantially attenuate radio frequency signals. The visibility of the one or more conductive films **208** can be relatively low such that individuals can readily see through the conductive films **208**. In one instance, a conductive film **208** disposed between the first and second repeaters **202**, **204** can be placed on one side or the other of the structural element **206**. In another instance, conductive films disposed between the first and second repeaters **202**, **204** can be placed on both side of the structural element **206**. In one aspect, the one or more conductive films **208** include openings that can be disposed between the power couplers **212**, **226**, and between the RF coupling antennas **216**, **230** to permit RF communications signal and power transmission signals to readily couple between the first and second repeaters **202**, **204**. The conductive film **208** can, however, block other conductive paths of the RF signals between the first and second repeater **202**, **204** thereby reducing feedback. The conductive film **208** therefore can be utilized to increase antenna-to-antenna isolation between the transmission antennas **218**, **232**, between the coupling antenna **216** of the first repeater and the transmission antenna **232** of the second repeater, and/or between the coupling antenna **230** of the second repeater **204** and the transmission antenna **218** of the first repeater **202**. In another aspect, the one or more conductive films **208** may not include openings to increase antenna-to-antenna isolation between the transmission antennas **218**, **232**, between the coupling antenna **216** of the first repeater and the transmission antenna **232** of the second repeater, and/or between the coupling antenna **230** of the second repeater **204** and the transmission antenna **218** of the first repeater **202**. A first shielding path can be between the coupling antenna **216** of the first repeater and the structural element

206. A second shielding path can be between the coupling antenna **230** of the second repeater **204** and the structural element **206**. The first or second shielding path can substantially limit electromagnetic waves passing through the one or more openings in the conductive film to the electromagnetic signal or photonic energy associated with the coupling antennas of the first and second repeater. The use of the openings in the conductive films, combined with the shielding paths, enables an increased efficiency in passing the wireless signal between the coupling antennas of the first and second repeaters, while maintaining an increased isolation between the transmission antennas of the first and second repeaters due to the conductive film. In one example, the shielding path can be comprised of a material that substantially blocks electromagnetic waves. For example, metallic tape can be used to form the first shielding path or the second shielding path. The first or second shielding path can be shaped based on the beam shape formed by the coupling antenna **216** of the first repeater **202** or the coupling antenna **230** of the second repeater **204**.

[0046] In one aspect, the first repeater **202** and/or the second repeater **204** can be affixed to the structural element **206** by an adhesive such as glue or tape. In another aspect, the first repeater **202** and/or the second repeater **204** can be affixed to the structural element **206** by a magnet, if the structural element **206** is non-metallic. The magnets may also be utilized to align the power couplers **212**, **226** of the first and second repeaters **202**, **204**. In yet other aspects, other fastening means or combinations thereof can be used to affix the first and second repeater **202**, **204** to the structural element, such as nails, screws, adhesive backed hook and loop fasteners, or the like.

[0047] FIGS. 3A, 3B and 3C depict a wireless system, in accordance with another example. In one aspect, the wireless system includes a first repeater **302** and a second repeater **304**. The first and second repeaters **302**, **304** are adapted for disposition opposite each other about a structural element **306**, such as a window, non-metallic car body panel or similar element. In one instance, the first repeater **302** can be an inside repeater adapted for placement within a vehicle **306** or similar structure, and the second repeater **304** can be an outside repeater adapted for placement outside the vehicle **306**. In one aspect, the various functions of the repeaters **302**, **304**, can be implemented in hardware, firmware, software stored in memory and executed by one or more processing units, and/or any combination thereof.

[0048] In one aspect, the first repeater **302** can include a wireless power transmitter (WPT) **310**, a power coupler **312**, one or more bi-directional amplifiers (BDA) **314**, one or more RF coupling antennas **316**, and one or more optional transmission antennas **318**. In one aspect, the second repeater **304** can include a wireless power receiver (WPR) **324**, a power coupler **326**, one or more bi-directional amplifiers (BDA) **328**, one or more RF coupling antennas **330**, and one or more optional transmission antennas **332**. The wireless system may optionally include one or more conductive films **308** for disposition between the first and second repeaters **302**, **304**.

[0049] In one aspect, the one or more bi-directional amplifiers **314** of the first repeater **302** can be configured to amplify one or more RF communication signals. In one aspect, the one or more bi-directional amplifiers **328** of the second repeater **304** can be configured to amplify the one or more RF communication signals. In one instance, the one or

more bi-directional amplifiers **314**, **328** can be configured to amplify both uplink and downlink 3GPP LTE signals.

[0050] In one aspect, the transmission antenna **332** of the second repeater **304** can be an omni-directional antenna. An omni-directional antenna may advantageously be utilized with vehicles that move about with respect base stations of the service provider. In one aspect, the transmission antenna **332** of the second repeater **304** can be directly or indirectly coupled to the second repeater **304**. In one instance, the transmission antenna **332** of the second repeater may be located adjacent to or on a metallic body panel of the vehicle to increase antenna-to-antenna isolation between the transmission antennas **318**, **332**. In one aspect, the transmission antenna **318** of the first repeater **302** can be a directional antenna to reduce feedback between the transmission antennas **318**, **332**, between the transmission antenna **318** and the RF coupling antenna **330**, or between the transmission antenna **318** and the RF coupling antenna **316**.

[0051] In one aspect, the one or more bi-directional amplifiers **314** of the first repeater **302** can include one or more RF transmission ports **320** and one or more RF coupling ports **322**. The one or more transmission antennas **318** can be coupled to the respective one or more RF transmission ports **320**, and the one or more RF coupling antennas **316** can be coupled to the respective one or more RF coupling ports **322** of the first repeater **302**. In one aspect, the one or more bi-directional amplifiers **328** of the second repeater **304** can include one or more RF transmission ports **334** and one or more RF coupling ports **336**. The one or more transmission antennas **332** can be coupled to the respective one or more RF transmission ports **334**, and the one or more RF coupling antennas **330** can be coupled to the respective one or more RF coupling ports **336** of the second repeater **304**.

[0052] In one aspect, the bi-directional amplifier **328** of the second repeater can boost one or more RF communication signal received from and transmitted to a base station. The bi-directional amplifier **328** can improve the gain and/or noise-power on uplink and/or downlink communication RF signals, at the RF transmission port **334** of the bi-directional amplifier **328**, to increase the range and/or increase the signal strength of RF communication signal between the second repeater **304** and base stations of a service provider. On the downlink path the second repeater **304** can preserve the signal-to-noise ratio and can set the noise figure for the system at a much lower level than otherwise. On the uplink, the second repeater **304** enables a much stronger signal to be transmitted and therefore reach the BS in more cases. In some instances, the gain or noise power as measured at the RF transmission port **334** or transmission antenna **332** of the second repeater **304** can be constrained by a government agency, an industry standard, or similar regulatory entity. Accordingly, the bi-directional amplifier **328** of the second repeater **304** can be configured to provide a gain or noise power level as measured at the RF transmission port **334** or transmission antenna **332** of the second repeater **304** to comply with such constrains. In one aspect, the bi-directional amplifier **328** can be configured to control the uplink and downlink power supplied by the bi-directional amplifier **328** independently.

[0053] In one aspect, the structural element **306**, such as a windshield or similar element can appreciable reduce the signal strength of RF signals entering the vehicle. Therefore, in one aspect, the bi-directional amplifier **314** of the first repeater **302** and/or the bi-directional amplifier **328** of the

second repeater **304** can boost the one or more RF communication signals transmitted through the windshield or similar structural element. The bi-directional amplifier **314** of the first repeater **302** and/or the bi-directional amplifier **328** of the second repeater can improve the gain and/or noise power on uplink and/or downlink communication RF signals, at the RF coupling port **322** of the bi-directional amplifier **314** and/or at the RF coupling port **336** of the bi-directional amplifier **328**, to compensate for the loss through the structural element **306**. The gain or noise power of at the RF coupling port **322** of the bi-directional amplifier **314** and/or at the RF coupling port **336** of the bi-directional amplifier **328** can be selected such that the losses introduced by the structural element **306** reduces feedback through the one or more transmission antennas **318** of the first repeater **302** and/or the one or more transmission antenna **332** of the second repeater **304**.

[0054] In one aspect, the bi-directional amplifier **314** of the first repeater **302** can transmit, with little or no boost, the RF communication signals to one or more UEs within the vehicle **306**. Optionally, the bi-directional amplifier **314** of the first repeater **302** can boost the one or more RF communication signals for transmission to the one or more UEs. The bi-directional amplifier **314** can improve the gain and/or noise power on uplink and/or downlink communication RF signals, at the RF transmission port **320** of the bi-directional amplifier **314**, to increase the range and/or increase the signal strength of RF communication signal between the first repeater **302** and one or more UEs within the structure. In some instances, the gain or noise power as measured at the RF transmission port **320** or transmission antenna **218** of the first repeater **302** can be constrained by a government agency, an industry standard, or similar regulatory entity. Accordingly, the bi-directional amplifier **314** of the first repeater **302** can be configured to provide a gain or noise power level as measured at the RF transmission port **320** or transmission antenna **318** of the first repeater **302** to comply with such constrains. In one aspect, the bi-directional amplifier **314** can be configured to control the uplink and downlink power supplied by the bi-directional amplifier **314** independently.

[0055] In one instance, the bi-directional amplifier **228** of the first and second repeaters **302**, **304** can provide approximately 30-40 dB of gain. In addition, the transmission antenna **318** of the first repeater **302** can be an internal integral directional antenna, while the transmission antenna **332** of the second repeater **304** can be an external integral omnidirectional antenna.

[0056] In one aspect, the amount of gain provided by the first repeater **302** and/or the second repeater **304** can be based upon the transmission loss across the structural element **306**. In one aspect, the first and second repeater **302**, **304** can use RF reference signals or RF communication signals to determine the transmission loss across the structural element **306** coupling the repeaters. In one aspect, the second repeater **304** can further include a signal generator. The first repeater **302** can further include a transmission loss detector and a gain controller. The signal generator of the second repeater **304** can generate RF reference signals at a predetermined amplitude or power for transmission across the structural element **306** to the first repeater **302**. The transmission loss detector of the first repeater **302** determines a transmission loss across the structural element **306** based on the amplitude or power of the received RF refer-

ence signals. The gain controller of the first repeater **302** can adjust a gain or noise power of the amplifier of one or both of the repeaters **302**, **304** to compensate for the determined transmission loss across the structural element **306**. The RF reference signals can advantageously be used to calibrate one or both of the amplifiers, while the repeaters can continuously amplify the RF communication signals.

[0057] In another aspect, the second repeater **304** can further include a signal detector. The first repeater **302** can further include a transmission loss detector and a gain controller. The signal detector of the second repeater **304** can determine the amplitude or power of the RF communication signals as received at the second repeater **304**. The transmission loss detector of the first repeater **302** can determine the transmission loss across the structural element **306** based upon the amplitude or power of the RF communication signals as received at the second repeater **304** and the first repeater **302**. The gain controller of the first repeater **302** can adjust the gain or noise power of one or both of the repeaters **302**, **304** to compensate for the determined transmission loss across the structural element **306**. The RF communication signals can again be used advantageously to calibrate one or both of the amplifiers, while the repeaters can continuously amplify the RF communication signals.

[0058] In one aspect, the wireless power transmitter **310** and the power coupler **312** of the first repeater **302** make up a first wireless power unit, and the wireless power receiver **324** and the power coupler **326** of the second repeater **302** make up a second wireless power unit. The wireless power transmitter **310** of the first repeater **302** can be coupled to the power coupler **312**. In one aspect, the wireless power receiver **324** of the second repeater **304** can be coupled to the power coupler **326**. In one aspect, the power couplers **312**, **326** of the first and second repeaters **302**, **304** can be inductive coils for non-radiative techniques using magnetic fields. In another aspect, the power couplers **312**, **326** of the first and second repeaters **302**, **304** can be capacitive electrodes for radiative techniques using electric fields.

[0059] In one aspect, the wireless power transmitter **310** can convert a portion of DC or AC power received from a power source of the first repeater **302** to a RF power signal. The RF power signal can be transmitted from the power coupler **312** of the first repeater **302** through the structural element of the vehicle **306**, such as the windshield, and received by the power coupler **326** of the second repeater **304**. The wireless power receiver **324** can convert the RF power signal received by the power coupler **326** into a DC or AC power. The DC or AC power from the wireless power receiver **324** can power the second repeater **304**.

[0060] As discussed above, the bi-directional amplifier **328** of the second repeater **304** can be configured to control the uplink and downlink power supplied by the bi-directional amplifier **328** independently. In one aspect, the power supplied by the bi-directional amplifier **328** can be configured to provide respective power levels for the uplink and downlink signal transmission within applicable limits that may be set by one or more regulatory entities. In other aspects, it is to be appreciated that the uplink transmission power level typically is greater than the downlink transmission power level. In addition, the size of the wireless power transmitter **310**, wireless power receiver **324** and power couplers **312**, **326** tend to increase as the amount of power needed by the second repeater **304** increases. Therefore, the bi-directional amplifier **328** of the second repeater **304** can

be operated in a passive mode, whereby the bi-directional amplifier **328** supplies little or no additional power during transmission of uplink signals.

[0061] In one aspect, the wireless power transfer between the first and second repeaters **302**, **304** provided by the wireless power transmitter **310**, wireless power receiver **324** and power couplers **312**, **326** enable easy installation of the second repeater **304** on the outside of the structure. Installation can be simplified because one or more cables coupling the first and second repeaters **302**, **304** are not used, and therefore do not need to be routed through or around structural elements such as windows, doors or body panels. Eliminating the need to route cables coupling the first and second repeaters **302**, **304**, provided by the present technology, may be particularly advantageous for consumers doing their own installation, and/or deployment in structures that may be rented or leased such as apartments or leased cars. The outside second repeater **304** of the present technology also advantageously sets the noise figure and increases performance as compared to a single inside repeater or locating both the first and second repeaters inside a structure.

[0062] In one aspect, the one or more conductive films **308** can be transparent films or substantially transparent films. A conductive film **308** can be substantially transparent when it has a visible light transmittance of 70% or more. In one instance, the transparent conductive films may be a film of thin metal wires. The visibility of the one or more conductive films **308** can be relatively low such that individuals can readily see through the conductive film **308**. In one instance, a conductive film **308**, disposed between the first and second repeaters **302**, **304**, can be placed on one side or the other of the windshield of the vehicle **306**. In another instance, conductive films, disposed between the first and second repeaters **302**, **304**, can be placed on both side of the windshield of the vehicle **306**. In one aspect, the conductive film **308** includes openings that can be disposed between the power coupler **312**, **326**, and between the RF coupling antennas **316**, **330** to permit RF communications signal and power transmission signals to readily couple between the bi-directional amplifiers **314**, **328** of the first and second repeaters **302**, **304**. The conductive film **308** can, however, block other conductive paths of the RF signals between the first and second repeaters **302**, **304** thereby reducing feedback. The conductive film **308** therefore can be utilized to increase antenna-to-antenna isolation between the transmission antennas **318**, **332**, between the coupling antenna **316** of the first repeater and the transmission antenna **332** of the second repeater, and/or between the coupling antenna **330** of the second repeater **304** and the transmission antenna **318** of the first repeater **302**. In another aspect, the one or more conductive films **308** may not include openings to increase antenna-to-antenna isolation between the transmission antennas **318**, **332**, between the coupling antenna **316** of the first repeater and the transmission antenna **332** of the second repeater, and/or between the coupling antenna **330** of the second repeater **304** and the transmission antenna **318** of the first repeater **302**.

[0063] In one aspect, the first repeater **302** and/or the second repeater **304** can be affixed to the structural element **306** by an adhesive such as glue or tape. In another aspect, the first repeater **302** and/or the second repeater **304** can be affixed to the structural element **306** by a magnet. If the structural element **306** is non-metallic, the magnets may also be utilized to align the power couplers **312**, **326** of the first

and second repeaters **302, 304**. In yet other aspects, other fastening means or combinations thereof can be used to affix the first and second repeater **302, 304** to the structural element, such as nails, screws, adhesive backed hook and loop fasteners, or the like.

[0064] FIGS. **4A** and **4B** depict a wireless system, in accordance with another example. In one aspect, the wireless system includes a first repeater **402** and a second repeater **404**. In one aspect, the first repeater **402** can include an optical power transmitter (OPT) **406**, one or more bi-directional amplifiers (BDA) **408**, one or more RF coupling antennas **410**, and one or more optional transmission antennas **412**. In one aspect, the second repeater **404** can include an optical power receiver (OPR) **414**, one or more bi-directional amplifiers (BDA) **416**, one or more RF coupling antennas **418**, and one or more optional transmission antennas **420**. The wireless system may optionally include one or more conductive films **422** for disposition on a structural element **424** between the first and second repeaters **402, 404**. The one or more bi-directional amplifiers **408**, one or more RF coupling antennas **410** and one or more transmission antennas **412** of the first repeater **402**, and the one or more bi-directional amplifiers **416**, one or more RF coupling antennas **418** and one or more transmission antennas **420** of the second repeater **404** can function as described above with regard to FIG. **2**.

[0065] In one aspect, the optical power transmitter **406** can convert a portion of DC or AC power received from a power source of the first repeater **402** to optical energy. The optical energy can be transmitted from optical power transmitter **406** of the first repeater **402** through a transparent or substantially transparent structural element **424**, such as a window, and received by the optical power receiver **414** of the second repeater **404**. A structural element **424** can be substantially transparent when it has a visible light transmittance of 70% or more. The wireless power receiver **414** can convert the received optical energy into DC or AC power. The DC or AC power from the optical power receiver **414** can power the bi-directional amplifier **416** or any other circuits, as necessary, of the second repeater **404**. In one instance, the optical power transmitter **406** can transmit power to the optical power receiver **414** to enable generation of approximately 500 mA of steady state current, 1000 mA of peak current draw, and approximately 5-7.5 W of total power for use by the circuits of the second repeater **404**.

[0066] In one instance, the optical power transmitter **406** may transmit the power as laser light to the optical power receiver **414**. The laser light may be defocused in the optical power transmitter **406** to prevent the laser light from damaging the structural element **424** or harming individuals. Alternatively or in addition, the optical power transmitter **406** may initially transmit a relatively low power level of laser light. The relatively low power laser light received at the optical power receiver **414** can be measured to determine, as a safety mechanism, if the optical power transmitter **406** and the optical power receiver **414** are aligned. If the optical power transmitter **406** and optical power receiver **414** are determined to be aligned, the output power level of the laser light may be increase to a higher power level to power the second repeater **404**.

[0067] FIGS. **5A, 5B** and **5C** depict a wireless system, in accordance with another example. In one aspect, the wireless system includes a first repeater **502** and a second repeater **504**. In one aspect, the first repeater **502** can include

an optical power transmitter **506**, one or more bi-directional amplifiers **508**, one or more RF coupling antennas **510**, and one or more optional transmission antennas **512**. In one aspect, the second repeater **504** can include an optical power receiver **514**, one or more bi-directional amplifiers **516**, one or more RF coupling antennas **518**, and one or more optional transmission antennas **520**. The wireless system may optionally include one or more conductive films **522** for disposition on a structural element **524** between the first and second repeaters **502, 504**. The one or more bi-directional amplifiers **508**, one or more RF coupling antennas **510** and one or more transmission antennas **512** of the first repeater **502**, and the one or more bi-directional amplifiers **516**, one or more RF coupling antennas **518** and one or more transmission antennas **520** of the second repeater **504** can function as described above with regard to FIG. **3**.

[0068] In one aspect, the optical power transmitter **506** can convert a portion of power received from a power source of the first repeater **502** to optical energy. The optical energy can be transmitted from optical power transmitter **506** of the first repeater **502** through a transparent or substantially transparent structural element **524**, such as a windshield, and received by the optical power receiver **514** of the second repeater **504**. A structural element **524** can be substantially transparent when it has a visible light transmittance of 70% or more. The optical power receiver **514** can convert the received optical energy into a direct current (DC) power. The DC power from the optical power receiver **514** can power the second repeater **504**. In one instance, the optical power transmitter **506** can transmit power to the optical power receiver **514** to enable generation of approximately 500 mA of steady state current, 1000 mA of peak current draw, and approximately 5-7.5 W of total power for use by the circuits of the second repeater **504**.

[0069] In one instance, the optical power transmitter **506** may transmit the power as laser light to the optical power receiver **514**. The laser light may be defocused in the optical power transmitter **506** to prevent the laser light from damaging the structural element **524** or harming individuals. Alternatively or in addition, the optical power transmitter **506** may initially transmit a relatively low power level of laser light. The relatively low power laser light received at the optical power receiver **514** can be measured to determine, as a safety mechanism, if the optical power transmitter **506** and the optical power receiver **514** are aligned. If the optical power transmitter **506** and optical power receiver **514** are determined to be aligned, the output power level of the laser light may be increase to a higher power level to power the second repeater.

[0070] FIG. **6** depicts a wireless system, in accordance with another example. In one aspect, the wireless system includes a first repeater **602** and a second repeater **604**. The first and second repeaters **602, 604** are adapted for disposition opposite each other about a structural element **606**, such as a wall, window, windshield or similar element.

[0071] In one aspect, the first and second repeaters **602, 604** can include one or more RF channels. The RF channels can include one or more uplink (UL) channels **608, 610** and one or more downlink (DL) channels **612, 614**. In one instance, the uplink (UL) channels **608, 611** can include one or more high band (HB) channels **616, 618** and one or more low band (LB) channels **620, 624**. Similarly, the downlink

(DL) channels **612**, **614** can include one or more high band (HB) channels **624**, **626** and one or more low band (LB) channels **628**, **630**.

[0072] In one aspect, the first and second repeater **602**, **604** can include one or more splitters **632-638** and one or more diplexers **640-654**, or similar circuits, to separate and recombine the RF communication signals received on respective one or more transmission antennas **656**, **658** and one or more coupling antennas **660**, **662**. In another aspect, the splitter and diplexers, as illustrated in FIG. 6, can be switched to allow for narrow-band splitters. In another aspect, the splitters, as illustrated in FIG. 6, can be replaced with circulators or separate antennas. Each channel of the first and second repeater **602**, **604** can include one or more amplifier stages **664-678**. In one aspect, the one or more amplifier stages **664-678** can be configured to amplify respective uplink and downlink 3GPP LTE signals. In one aspect, internal oscillations can be less likely due to the separate coupling paths of the uplink and downlink channels.

[0073] In one aspect, the first repeater **602** also includes a wireless power transmitter **680** and a power coupler **682**. The second repeater **604** also includes a wireless power receiver **684** and a power coupler **686**. In one aspect, the power couplers **682**, **686** of the first and second repeaters **602**, **604** can be inductive coils for non-radiative techniques using magnetic fields. In another aspect, the power couplers **682**, **686** of the first and second repeaters **602**, **604** can be capacitive electrodes for radiative techniques using electric fields.

[0074] In one aspect, the wireless power transmitter **680** can convert a portion of DC or AC power received from a power source of the first repeater **602** to a RF power signal. The RF power signal can be transmitted from the power coupler **682** of the first repeater **602** through the structural element **606** and received by the power coupler **686** of the second repeater **604**. The wireless power receiver **684** can convert the RF power signal received by the power coupler **686** into DC or AC power. The DC or AC power from the wireless power receiver **684** can power the circuitry of the second repeater **604**. In one instance, the wireless power transmitter **680** can transmit power to the wireless power receiver **684** to enable generation of approximately 500 mA of steady state current, 1000 mA of peak current draw, and approximately 5-7.5 W of total power for use by the circuits of the second repeater **604**.

[0075] In one aspect, the Single-Input-Single-Output (SISO) architecture of the first and second repeater **602**, **604** may be characterized by lower current draw, as compared to conventional repeater architectures. The reduced current draw in the second repeater **604** may advantageously enable a reduction of the amount of power needed to be transferred between the wireless power transmitter **680** and wireless power receiver **684**, and also enable a reduction in the size of the power couplers **682**, **686**.

[0076] In another aspect, the first repeater **602** can include an optical power transmitter and the second repeater **604** can include an optical power receiver. In one aspect, the optical power transmitter can convert a portion of power received from a power source of the first repeater **602** to optical energy. The optical energy can be transmitted from optical power transmitter of the first repeater **602** through a transparent or substantially transparent structural element **606**, such as a window, and received by the optical power receiver of the second repeater **604**. A structural element **606** can be

substantially transparent when it has a visible light transmittance of 70% or more. The optical power receiver can convert the received optical energy into DC or AC power. The DC or AC power from the optical power receiver can power the circuitry of the second repeater **604**. In one instance, the optical power transmitter can transmit power to the optical power receiver to enable generation of approximately 500 mA of steady state current, 1000 mA of peak current draw, and approximately 5-7.5 W of total power for use by the circuits of the second repeater **604**.

[0077] In one aspect, the wireless system may optionally include one or more conductive films for disposition between the first and second repeaters **602**, **604**. In one aspect, the one or more conductive films can be transparent or substantially transparent films. A conductive film can be substantially transparent when it has a visible light transmittance of 70% or more. In one instance, the transparent conductive films may be a film of thin metal wires. The visibility of the one or more conductive films can be relatively low such that individuals can readily see through the conductive films. In one instance, a conductive film disposed between the first and second repeaters **602**, **604** can be placed on one side or the other of the structural element **606**. In another instance, conductive films disposed between the first and second repeaters **602**, **604** can be placed on both side of the structural element **606**. In one aspect, the one or more conductive films include openings that can be disposed between the power couplers **682**, **686**, and between the RF coupling antennas **660**, **662** to permit RF communications signal and power transmission signals to readily couple between the first and second repeaters **602**, **604**. The conductive film can, however, block other conductive paths of the RF signals between the first and second repeater **602**, **604** thereby reducing feedback. The conductive film therefore can be utilized to increase antenna-to-antenna isolation between the transmission antennas **656**, **658**, between the coupling antenna **660** of the first repeater **602** and the transmission antenna **658** of the second repeater **604**, and/or between the coupling antenna **662** of the second repeater **604** and the transmission antenna **656** of the first repeater **602**. In another aspect, the one or more conductive films may not include openings to increase antenna-to-antenna isolation between the transmission antennas **656**, **658**, between the coupling antenna **660** of the first repeater **602** and the transmission antenna **658** of the second repeater **604**, and/or between the coupling antenna **662** of the second repeater **604** and the transmission antenna **656** of the first repeater **602**.

[0078] FIG. 7 depicts a wireless system, in accordance with another example. In one aspect, the wireless system includes a first repeater **702** and a second repeater **704**. The first and second repeaters **702**, **704** are adapted for disposition opposite each other about a structural element **706**, such as a wall, a window, a windshield or similar element.

[0079] In one aspect, the first and second repeaters **702**, **704** can include one or more RF channels. The RF channels can include one or more uplink (UL) channels **708**, **710** and one or more downlink (DL) channels **712**, **714**. In one instance, the uplink (UL) channels **708**, **710** can include one or more high band (HB) channels **716**, **718** and one or more low band (LB) channels **720**, **722**. Similarly, the downlink (DL) channels **712**, **714** can include one or more high band (HB) channels **724**, **726** and one or more low band (LB) channels **728**, **730**.

[0080] In one aspect, the first and second repeater 702, 704 can include one or more splitters 732, 734 and one or more diplexers 736-750, or similar circuits, to separate and recombine the RF communication signals received on respective one or more transmission antennas 752, 754 and one or more coupling antennas 756-762. In another aspect, the splitter and diplexers, as illustrated in FIG. 7, can be switched to allow for narrow-band splitters. In another aspect, the splitters, as illustrated in FIG. 7, can be replaced with circulators or separate antennas. Each channel of the first and second repeater 702, 704 can include one or more amplifier stages 764-778. In one aspect, the one or more amplifier stages 764-778 can be configured to amplify respective uplink and downlink 3GPP LTE signals. In one aspect, internal oscillations can be less likely due to the separate coupling paths of the uplink and downlink channels.

[0081] In one aspect, the first repeater 702 also includes a wireless power transmitter 780 and a power coupler 782. The second repeater 704 also includes a wireless power receiver 784 and a power coupler 786. In one aspect, the power couplers 782, 786 of the first and second repeaters 702, 704 can be inductive coils for non-radiative techniques using magnetic fields. In another aspect, the power couplers 782, 786 of the first and second repeaters 702, 704 can be capacitive electrodes for radiative techniques using electric fields.

[0082] In one aspect, the wireless power transmitter 780 can convert a portion of DC or AC power received from a power source of the first repeater 702 to a RF power signal. The RF power signal can be transmitted from the power coupler 782 of the first repeater 702 through the structural element 706 and received by the power coupler 786 of the second repeater 704. The wireless power receiver 784 can convert the RF power signal received by the power coupler 786 into DC or AC power. The DC or AC power from the wireless power receiver 784 can power the circuitry of the second repeater 704. In one instance, the wireless power transmitter 780 can transmit power to the wireless power receiver 786 to enable generation of approximately 500 mA of steady state current, 1000 mA of peak current draw, and approximately 5-7.5 W of total power for use by the circuits of the second repeater 704.

[0083] In one aspect, the SISO architecture of the first and second repeater 702, 704 may be characterized by lower current draw, as compared to conventional repeater architectures. The reduced current draw in the second repeater 704 may advantageously enable a reduction of the amount of power needed to be transferred between the wireless power transmitter 780 and wireless power receiver 784, and also enable a reduction in the size of the power couplers 782, 786.

[0084] In another aspect, the first repeater 702 can include an optical power transmitter and the second repeater 704 can include an optical power receiver. In one aspect, the optical power transmitter can convert a portion of power received from a power source of the first repeater 702 to optical energy. The optical energy can be transmitted from optical power transmitter of the first repeater 702 through a transparent or substantially transparent structural element 706, such as a window, and received by the optical power receiver of the second repeater 704. A structural element 706 can be substantially transparent when it has a visible light transmittance of 70% or more. The optical power receiver can convert the received optical energy into DC power. The DC

power from the optical power receiver can power the circuitry of the second repeater 704. In one instance, the optical power transmitter can transmit power to the optical power receiver to enable generation of approximately 500 mA of steady state current, 1000 mA of peak current draw, and approximately 5-7.5 W of total power for use by the circuits of the second repeater 704.

[0085] In one aspect, the wireless system may optionally include one or more conductive films for disposition between the first and second repeaters 702, 704. In one aspect, the one or more conductive films can be transparent or substantially transparent films. A conductive film can be substantially transparent when it has a visible light transmittance of 70% or more. In one instance, the transparent conductive films may be a film of thin metal wires. The visibility of the one or more conductive films can be relatively low such that individuals can readily see through the conductive films. In one instance, a conductive film, disposed between the first and second repeaters 702, 704, can be placed on one side or the other of the structural element 706. In another instance, conductive films, disposed between the first and second repeaters 702, 704, can be placed on both side of the structural element 706. In one aspect, the one or more conductive films include openings that can be disposed between the power couplers 782, 786, and between the RF coupling antennas 756-762 to permit RF communications signal and power transmission signals to readily couple between the first and second repeaters 702, 704. The conductive film can, however, block other conductive paths of the RF signals between the first and second repeater 702, 704 thereby reducing feedback. The conductive film therefore can be utilized to increase antenna-to-antenna isolation between the transmission antennas 752, 754, between the coupling antennas 756, 760 of the first repeater 702 and the transmission antenna 754 of the second repeater 704, and/or between the coupling antennas 758, 762 of the second repeater 704 and the transmission antenna 752 of the first repeater 702. In another aspect, the one or more conductive films may not include openings to increase antenna-to-antenna isolation between the transmission antennas 752, 754, between the coupling antenna 756, 760 of the first repeater 702 and the transmission antenna 754 of the second repeater 704, and/or between the coupling antenna 758, 762 of the second repeater 704 and the transmission antenna 752 of the first repeater 702.

[0086] FIG. 8 depicts a wireless system, in accordance with another example. In one aspect, the wireless system includes a first repeater 802 and a second repeater 804. The first and second repeaters 802, 804 are adapted for disposition opposite each other about a structural element 806, such as a wall, a window, a windshield or similar element.

[0087] In one aspect, the first and second repeaters 802, 804 can include one or more RF channels. The RF channels can include one or more uplink (UL) channels 808, 810 and one or more downlink (DL) channels 812, 814. In one instance, the uplink (UL) channels 808, 810 can include one or more high band (HB) channels 816, 818 and one or more low band (LB) channels 820, 822. Similarly, the downlink (DL) channels 812, 814 can include one or more high band (HB) channels 824, 826 and one or more low band (LB) channels 828, 830.

[0088] In one aspect, the first and second repeater 802, 804 can include one or more splitters 832-842 and one or more diplexers 844-850, or similar circuits, to separate and recom-

bine the RF communication signals received on respective one or more transmission antennas **852**, **854** and one or more coupling antennas **856-862**. In another aspect, the splitter and diplexers, as illustrated in FIG. 8, can be switched to allow for narrow-band splitters. In another aspect, the splitters, as illustrated in FIG. 8, can be replaced with circulators or separate antennas. Each channel of the first and second repeater **802**, **804** can include one or more amplifier stages **864-878**. In one aspect, the one or more amplifier stages **864-878** can be configured to amplify respective uplink and downlink 3GPP LTE signals. In one aspect, internal oscillations can be less likely due to the separate coupling paths of the uplink and downlink channels.

[0089] In one aspect, the first repeater **802** also includes a wireless power transmitter **880** and a power coupler **882**. The second repeater **804** also includes a wireless power receiver **884** and a power coupler **886**. In one aspect, the power couplers **882**, **886** of the first and second repeaters **802**, **804** can be inductive coils for non-radiative techniques using magnetic fields. In another aspect, the power couplers **882**, **886** of the first and second repeaters **802**, **804** can be capacitive electrodes for radiative techniques using electric fields.

[0090] In one aspect, the wireless power transmitter **880** can convert a portion of DC or AC power received from a power source of the first repeater **002** to a RF power signal. The RF power signal can be transmitted from the power coupler **882** of the first repeater **802** through the structural element **806** and received by the power coupler **886** of the second repeater **804**. The wireless power receiver **884** can convert the RF power signal received by the power coupler **886** into DC or AC power. The DC or AC power from the wireless power receiver **884** can power the circuitry of the second repeater **804**. In one instance, the wireless power transmitter **880** can transmit power to the wireless power receiver **884** to enable generation of approximately 500 mA of steady state current, 1000 mA of peak current draw, and approximately 5-7.5 W of total power for use by the circuits of the second repeater **804**.

[0091] In one aspect, the SISO architecture of the first and second repeater **802**, **804** may be characterized by lower current draw, as compared to conventional repeater architectures. The reduced current draw in the second repeater **804** may advantageously enable a reduction of the amount of power needed to be transferred between the wireless power transmitter **880** and wireless power receiver **884**, and also enable a reduction in the size of the power couplers **882**, **886**.

[0092] In another aspect, the first repeater **802** can include an optical power transmitter and the second repeater **804** can include an optical power receiver. In one aspect, the optical power transmitter can convert a portion of DC or AC power received from a power source of the first repeater **802** to optical energy. The optical energy can be transmitted from optical power transmitter of the first repeater **802** through a transparent or substantially transparent structural element **806**, such as a window, and received by the optical power receiver of the second repeater **804**. A structural element **806** can be substantially transparent when it has a visible light transmittance of 70% or more. The optical power receiver can convert the received optical energy into DC or AC power. The DC or AC power from the optical power receiver can power the circuitry of the second repeater **804**. In one instance, the optical power transmitter can transmit power to

the optical power receiver to enable generation of approximately 500 mA of steady state current, 1000 mA of peak current draw, and approximately 5-7.5 W of total power for use by the circuits of the second repeater **804**.

[0093] In one aspect, the wireless system may optionally include one or more conductive films for disposition between the first and second repeaters **802**, **804**. In one aspect, the one or more conductive films can be transparent or substantially transparent films. A conductive film can be substantially transparent when it has a visible light transmittance of 70% or more. In one instance, the transparent conductive films may be a film of thin metal wires. The visibility of the one or more conductive films can be relatively low such that individuals can readily see through the conductive films. In one instance, a conductive film, disposed between the first and second repeaters **802**, **804**, can be placed on one side or the other of the structural element **806**. In another instance, conductive films, disposed between the first and second repeaters **802**, **804**, can be placed on both side of the structural element **806**. In one aspect, the one or more conductive films include openings that can be disposed between the power couplers **882**, **886**, and between the RF coupling antennas **856-862** to permit RF communications signal and power transmission signals to readily couple between the first and second repeaters **802**, **784**. The conductive film can, however, block other conductive paths of the RF signals between the first and second repeater **802**, **804** thereby reducing feedback. The conductive film therefore can be utilized to increase antenna-to-antenna isolation between the transmission antennas **852**, **854**, between the coupling antennas **856**, **860** of the first repeater **802** and the transmission antenna **854** of the second repeater **804**, and/or between the coupling antennas **858**, **862** of the second repeater **804** and the transmission antenna **852** of the first repeater **802**. In another aspect, the one or more conductive films may not include openings to increase antenna-to-antenna isolation between the transmission antennas **852**, **854**, between the coupling antenna **856**, **860** of the first repeater **802** and the transmission antenna **854** of the second repeater **804**, and/or between the coupling antenna **858**, **862** of the second repeater **804** and the transmission antenna **852** of the first repeater **802**.

[0094] FIG. 9 depict a wireless system, in accordance with another example. In one aspect, the wireless system includes a first repeater **902**, a first wireless power unit **904**, a second repeater **906**, and a second wireless power unit **908**. The wireless system may optionally include one or more conductive films **910** for disposition on a structural element **912** between the first and second wireless power units **904**, **906**.

[0095] In one aspect, the first repeater **902** can include one or more bi-directional amplifiers (BDA) **914**, one or more RF coupling antennas **916**, and one or more optional transmission antennas **918**. In one aspect, the second repeater **906** can include one or more bi-directional amplifiers **920**, one or more RF coupling antennas **922**, and one or more optional transmission antennas **924**. The one or more bi-directional amplifiers **914**, one or more RF coupling antennas **916** and one or more transmission antennas **916** of the first repeater **902**, and the one or more bi-directional amplifiers **920**, one or more RF coupling antennas **922** and one or more transmission antennas **924** of the second repeater **906** can function as described above with regard to FIGS. 2A-8.

[0096] In one aspect, the first wireless power unit **904** can be coupled to the first repeater **902** by one or more conduc-

tive power links **926**, and the second wireless power unit **908** can be coupled to the second repeater **906** by one or more conductive power links **928**. In one instance, the conductive power links **926**, **928** may be one or more cables configured to electrically couple the first and second wireless power units **904**, **908** to the respective first and second repeaters **902**, **906**. In one aspect, the first wireless power unit **904** can include a wireless power transmitter (WPT) **930** and a power coupler **932**. In one aspect, the second wireless power unit **908** can include a wireless power receiver (WPR) **934** and a power coupler **936**. In one aspect, the wireless power transmitter **930** can convert a portion of Direct Current (DC) or Alternating Current (AC) electrical power received from a power source of the first repeater **902** to a RF power signal. The RF power signal can be transmitted from the power coupler **932** of the first wireless power unit **904** through the structural element **912** and received by the power coupler **936** of the second wireless power unit **908**. The wireless power receiver **908** can convert the RF power signal received by the power coupler **936** into DC or AC electrical power. The DC or AC electrical power from the wireless power receiver **934** can power the second repeater **906**. In one instance, the wireless power transmitter **930** can transmit power to the wireless power receiver **934** to enable generation of approximately 500 mA of steady state current, 1000 mA of peak current draw, and approximately 5-7.5 W of total power for use by the circuits of the second repeater **906**.

[0097] In another aspect, the first wireless power unit **904** can include an optical power transmitter, and the second wireless power unit **908** can include an optical power receiver. In one aspect, the optical power transmitter can convert a portion of DC or AC power received from a power source of the first repeater **902** to optical energy. The optical energy can be transmitted from optical power transmitter through a transparent or substantially transparent structural element **912**, such as a window or windshield, and received by the optical power receiver. A structural element **912** can be substantially transparent when it has a visible light transmittance of 70% or more. The wireless power receiver can convert the received optical energy into DC or AC power. The DC or AC power from the optical power receiver can power the second repeater **906**. In one instance, the optical power transmitter **930** can transmit power to the optical power receiver **934** to enable generation of approximately 500 mA of steady state current, 1000 mA of peak current draw, and approximately 5-7.5 W of total power for use by the circuits of the second repeater **906**.

[0098] In one instance, the optical power transmitter **930** may transmit the power as laser light to the optical power receiver **934**. The laser light may be defocused in the optical power transmitter **930** to prevent the laser light from damaging the structural element **912** or harming individuals. Alternatively or in addition, the optical power transmitter **930** may initially transmit a relatively low power level of laser light. The relatively low power laser light received at the optical power receiver **934** can be measured to determine, as a safety mechanism, if the optical power transmitter **930** and the optical power receiver **934** are aligned. If the optical power transmitter **930** and optical power receiver **934** are determined to be aligned, the output power level of the laser light transmitted by the optical power transmitter **930** may be increase to a higher power level to power the second repeater **906**.

[0099] In one aspect, the combination of the first wireless power unit **904** coupled to the first repeater **902** by one or more conductive power links **926**, and the second wireless power unit **908** coupled to the second repeater **906** by one or more conductive power links **928** advantageously enables the first and second wireless power units **904**, **908** to be placed on a structural element **912** such as a window or windshield adapted for transferring power between the wireless power units **904**, **908**. The first and second repeaters **902**, **906** in turn can be place on a different structural element adapted for transferring RF signals between the repeaters **902**, **906** or desired placement of the transmission antennas **918**, **924** of the repeaters **902**, **906**. The separate first and second wireless power units **904**, **908**, will typically have a reduced form factor which may advantageously reduce the visible obstruction of the first and second wireless power unit **904**, **908** when placed for example on a windshield and the first and second repeaters **902**, **906** are placed on a car body panel. The separate first and second wireless power units **904**, **908** may also advantageously be sold separately from the first and second repeaters **902**, **906** so that customers can choose the wireless power function as a peripheral depending upon the particular customer's application for example, and also advantageously be added later as a particular customer's application changes.

[0100] FIG. 10 depict a wireless system, in accordance with another example. In one aspect, the wireless system includes a first repeater **1005** and a second repeater **1010**. In one aspect, the first repeater **1005** is configured to compensate for RF transmission loss across a structural element **1015** disposed between the first and second repeaters **1005**, **1010**. In another aspect, the second repeater **1010** is configured to compensate for RF transmission loss across the structural element **1015**. In yet another aspect, the first repeater **1005** is configured to compensate for a first portion of the RF transmission loss and the second repeater **1010** is configured to compensate for a second portion of the RF transmission loss across the structural element **1015**.

[0101] In one aspect, the first repeater **1005** can be disposed outside a structure and the second repeater **1010** can be disposed inside the structure. In one instance, the structure can be a residential or commercial building. In one instance, the structural element **1015** can be a wall, door or window of the building. In another instance, the structure can be a vehicle such as a car, bus, train, truck, boat, or recreational vehicle (RV). In one aspect, the first repeater is coupled to power outside the structure. In one instance, the structural element **1015** can be a windshield or window of the vehicle.

[0102] In one aspect, the first repeater **1005** can be coupled to power outside the structure, and the second repeater **1010** can be coupled to power inside the structure. In one instance, the first repeater **1005** can be plugged into an outside electrical outlet **1020**, and the second repeater **1010** can be plugged into an inside electrical outlet **1025** of the structure. In another instance, the first repeater **1005** can be wired to a battery of the vehicle, and the second repeater **1010** can be plugged into a power outlet within the vehicle.

[0103] In one aspect, the first repeater **1005** can include one or more bi-directional amplifiers (BDA) **1030**, one or more RF coupling antennas **1035**, and one or more optional transmission antennas **1040**. In one aspect, the second repeater **1010** can include one or more bi-directional amplifiers **1045**, one or more RF coupling antennas **1050**, and one

or more optional transmission antennas **1055**. The one or more bi-directional amplifiers **1030**, one or more RF coupling antennas **1035** and one or more transmission antennas **1040** of the first repeater **1005**, and the one or more bi-directional amplifiers **1045**, one or more RF coupling antennas **1050** and one or more transmission antennas **1055** of the second repeater **1010** can function as described above with regard to FIGS. 2A-8.

[**0104**] The wireless system may optionally include one or more conductive films for disposition on a structural element **1015** between the first and second repeater **1005**, **1010**. In one aspect, the one or more conductive films can be transparent or substantially transparent films. A conductive film can be substantially transparent when it has a visible light transmittance of 70% or more. In one instance, the transparent conductive films may be a film of thin metal wires. The visibility of the one or more conductive films can be relatively low such that individuals can readily see through the conductive films. In one instance, a conductive film disposed between the first and second repeaters **1005**, **1010** can be placed on one side or the other of the structural element **1015**. In another instance, conductive films disposed between the first and second repeaters **1005**, **1010** can be placed on both side of the structural element **1015**. In one aspect, the one or more conductive films include openings that can be disposed between the RF coupling antennas **1035**, **1050** to permit RF communications signal to readily couple between the first and second repeaters **1005**, **1010**. The conductive film can, however, block other conductive paths of the RF signals between the first and second repeater **1005**, **1010** thereby reducing feedback. The conductive film therefore can be utilized to increase antenna-to-antenna isolation between the transmission antennas **1040**, **1055**, between the coupling antenna **1035** of the first repeater **1005** and the transmission antenna **1055** of the second repeater **1010**, and/or between the coupling antenna **1050** of the second repeater **1010** and the transmission antenna **1040** of the first repeater **1005**. In another aspect, the one or more conductive films may not include openings to increase antenna-to-antenna isolation between the transmission antennas **1040**, **1055**, between the coupling antenna **1035** of the first repeater **1005** and the transmission antenna **1055** of the second repeater **1010**, and/or between the coupling antenna **1050** of the second repeater **1010** and the transmission antenna **1040** of the first repeater **1010**.

[**0105**] FIG. 11 depict a wireless system, in accordance with another example. In one aspect, the wireless system includes a first repeater **1105** and a second repeater **1110**. In one aspect, the first repeater **1105** is configured to compensate for RF transmission loss across a structural element **1115** disposed between the first and second repeaters **1105**, **1110**. In another aspect, the second repeater **1110** is configured to compensate for RF transmission loss across the structural element **1115**. In yet another aspect, the first repeater **1105** is configured to compensate for a first portion of the RF transmission loss and the second repeater **1110** is configured to compensate for a second portion of the RF transmission loss across the structural element **1115**.

[**0106**] In one aspect, the first repeater **1105** can be disposed outside a structure and the second repeater **1110** can be disposed inside the structure. In one instance, the structure can be a residential or commercial building. In one instance, the structural element **1115** can be a wall, door or window of the building. In another instance, the structure

can be a vehicle such as a car, bus, train, truck, boat, or recreational vehicle (RV). In one instance, the structural element **1115** can be a windshield or window of the vehicle.

[**0107**] In one aspect, the first repeater **1105** can be powered by a solar panel, and the second repeater **1110** can be coupled to power inside the structure. In one instance, the first repeater **1105** can be wired to a solar panel **1120** on the outside of the structure, and the second repeater **1110** can be plugged into an inside electrical outlet **1125** of the structure. In another instance, the first repeater **1105** can be wired to a solar panel mounted on a vehicle, and the second repeater **1110** can be plugged into a power outlet within the vehicle.

[**0108**] In one aspect, the first repeater **1105** can include one or more bi-directional amplifiers (BDA) **1130**, one or more RF coupling antennas **1135**, and one or more optional transmission antennas **1140**. In one aspect, the second repeater **1110** can include one or more bi-directional amplifiers **1145**, one or more RF coupling antennas **1150**, and one or more optional transmission antennas **1155**. The one or more bi-directional amplifiers **1130**, one or more RF coupling antennas **1135** and one or more transmission antennas **1140** of the first repeater **1105**, and the one or more bi-directional amplifiers **1145**, one or more RF coupling antennas **1150** and one or more transmission antennas **1155** of the second repeater **1110** can function as described above with regard to FIGS. 2A-8.

[**0109**] The wireless system may optionally include one or more conductive films for disposition on a structural element **1115** between the first and second repeater **1105**, **1110**. In one aspect, the one or more conductive films can be transparent or substantially transparent films. A conductive film can be substantially transparent when it has a visible light transmittance of 70% or more. In one instance, the transparent conductive films may be a film of thin metal wires. The visibility of the one or more conductive films can be relatively low such that individuals can readily see through the conductive films. In one instance, a conductive film disposed between the first and second repeaters **1105**, **1110** can be placed on one side or the other of the structural element **1115**. In another instance, conductive films disposed between the first and second repeaters **1105**, **1110** can be placed on both side of the structural element **1115**. In one aspect, the one or more conductive films include openings that can be disposed between the RF coupling antennas **1135**, **1150** to permit RF communications signal to readily couple between the first and second repeaters **1105**, **1110**. The conductive film can, however, block other conductive paths of the RF signals between the first and second repeater **1105**, **1110** thereby reducing feedback. The conductive film therefore can be utilized to increase antenna-to-antenna isolation between the transmission antennas **1140**, **1155**, between the coupling antenna **1135** of the first repeater **1105** and the transmission antenna **1155** of the second repeater **1110**, and/or between the coupling antenna **1150** of the second repeater **1110** and the transmission antenna **1140** of the first repeater **1105**. In another aspect, the one or more conductive films may not include openings to increase antenna-to-antenna isolation between the transmission antennas **1140**, **1155**, between the coupling antenna **1135** of the first repeater **1105** and the transmission antenna **1155** of the second repeater **1110**, and/or between the coupling antenna **1150** of the second repeater **1110** and the transmission antenna **1140** of the first repeater **1105**.

[0110] FIG. 12 depicts a wireless system, in accordance with another example. In one aspect, the wireless system includes a first repeater 1202 and a second repeater 1204. In one aspect, the first repeater 1202 can include an optical power transmitter (OPT) 1206, one or more bi-directional amplifiers (BDA) 1208, one or more RF-optical converters (ROC) 1210, one or more optical signal transceivers 1212, and one or more optional transmission antennas 1214. In one aspect, the second repeater 1204 can include an optical power receiver (OPR) 1216, one or more bi-directional amplifiers (BDA) 1218, one or more RF-optical converters (ROC) 1220, one or more optical signal transceivers 1222, and one or more optional transmission antennas 1224. The first and second repeaters 1202 and 1204 can be disposed about a structural element 1226. The one or more bi-directional amplifiers 1208 of the first repeater 1202, and the one or more bi-directional amplifiers 1218 of the second repeater 1204 can function as described above with regard to FIG. 2.

[0111] In one aspect, the one or more RF-optical converters (ROC) 1210 can be coupled between the one or more bi-directional amplifiers (BDA) 1208 and the one or more optical signal transceivers 1212 of the first repeater 1202. The RF-optical converters (ROC) 1210 can convert one or more RF communication signals from the one or more bi-directional amplifiers (BDA) 1208 to one or more optical communication signals for the one or more optical signal transceivers 1212. The RF-optical converters (ROC) 1210 can also convert one or more optical communication signals from the one or more optical transceivers 1212 to one or more RF communication signals for the one or more bi-directional amplifiers (BDA) 1208. Similarly, one or more RF-optical converters (ROC) 1220 can be coupled between the one or more bi-directional amplifiers (BDA) 1218 and the one or more optical signal transceivers 1222 of the second repeater 1204. The RF-optical converters (ROC) 1220 can convert one or more RF communication signals from the one or more bi-directional amplifiers (BDA) 1218 to one or more optical communication signals for the one or more optical signal transceivers 1222. The RF-optical converters (ROC) 1220 can also convert one or more optical communication signals from the one or more optical transceivers 1222 to one or more RF communication signals for the one or more bi-directional amplifiers (BDA) 1218.

[0112] In one aspect, the structural element 1226, such as a window, windshield or similar transparent element can appreciably reduce the signal strength of RF communication signals, such as uplink and downlink 3GPP LTE signals. Therefore, the RF-optical converters (ROC) 1210, 1220 can up-convert RF signals to optical signals and down-convert optical signal to RF signals. The optical signals can then be readily transmitted between the optical transceivers 1212, 1222 through one or more transparent or substantially transparent structural elements 1226. A structural element 1226 can be substantially transparent when it has a visible light transmittance of 70% or more. The term optical signal is not intended to be limiting. In one example, an optical signal, as used herein, can include a microwave frequency, a millimeter wave frequency, a terahertz frequency, or an optical frequency. Typically, a radio frequency is selected that has a lower loss through glass relative to a loss of the RF communication signals communicated between the device 110 and the base station 120 tower (see FIG. 1), when transmitted through glass.

[0113] In one aspect, the optical power transmitter 1206 can convert a portion of DC or AC power received from a power source of the first repeater 1202 to optical energy. The optical energy can be transmitted from optical power transmitter 1206 of the first repeater 1202 through a transparent or substantially transparent structural element 1226, such as a window, and received by the optical power receiver 1216 of the second repeater 1204. A structural element 1226 can be substantially transparent when it has a visible light transmittance of 70% or more. The wireless power receiver 1216 can convert the received optical energy into DC or AC power. The DC or AC power from the optical power receiver 1216 can power the bi-directional amplifier 1218, RF-optical converters 1220 or any other circuits, as necessary, of the second repeater 1204.

[0114] FIG. 13 depicts repeater system, in accordance with another example. In one aspect, the system includes a repeater 1302, an antenna 1304 and a flat cable 1306. The repeater 1302 and antenna 1304 are adapted for disposition opposite each other about a structural element 1308, such as a window, door or similar element. When the repeater 1302 and antenna 1304 are mounted on either side of a structural element they comprise a closely-contained system. Alternatively, the repeater 1302 and antenna 1304 may not be disposed opposite each other about the structural element 1308. In one instance, the repeater 1302 can be an inside repeater adapted for placement within a structure, and the antenna 1304 can be adapted for placement outside the structure attached to a window, wall or the like. In one aspect, the antenna can be a passive antenna. Alternatively, an antenna with an amplifier or other active components may be used.

[0115] In one aspect, the repeater can include one or more bi-directional amplifiers (BDA) 1310, and one or more optional transmission antennas 1312. The one or more transmission antennas 1312 may be integral to the repeater 1302, or may be separate from the first repeater 1302, but removably coupled to the bi-directional amplifier 1310 (e.g., remote external transmission antenna), optionally by one or more wired communication links (e.g., coaxial cable). The one or more bi-directional amplifiers 1310 can function as described above with regard to FIG. 2. In one aspect, the passive antenna 1304 can include an antenna, mounting structure and connector. The mounting structure can be adapted to be attached to the structural element 1302. The connector can be adapted to couple the antenna to the flat cable 1306. The passive antenna can be a directional antenna adapted for fixed structures such as buildings, or an omnidirectional antenna for mobile structures such as vehicles.

[0116] In one aspect, the flat cable 1306 can couple the repeater 1302 to the passive antenna 1304. In one aspect, the flat cable can include a body with a first coupler for coupling the repeater 1302 to a first end of the body and a second coupler for coupling to the passive antenna 1304 to a second end of the body. In one aspect, the body may include an approximately square or rectangular cross-sectional shape. The body may include a strip-line of sufficient width and dimensions such that general strip-line electromagnetic field principles apply to the body. The body may be formed using materials for printed circuit boards. In particular, the body may be formed using materials for flexible printed circuit boards. Alternatively, a polyimide film, such as Kapton, may be used to form selected layers of the body. In some embodiments, the body may be constructed using material

such that a general geometry of the body does not substantially change with the application of a perpendicular force to the body.

[0117] In one aspect, the flat cable **1306** includes a first ground layer, a second ground layer, a dielectric material, and a strip-line. The first ground layer and the second ground layer may be outer surfaces of two of the sides of the flat cable **1306**, such that the dielectric material and the strip-line are positioned between the first and second ground layers.

[0118] In one aspect, the ground layer can be substantially flat. The dielectric material can also be formed of layers. For example, a first dielectric layer may be located below the strip-line. A second dielectric layer may be located above the strip-line. Each dielectric layer can be substantially flat and positioned in parallel to the ground layer. The strip-line can be parallel to the ground layer and the layers of the dielectric material. The top ground layer can be substantially flat and parallel to the dielectric layers, strip-line, and ground layer. The top ground layer, dielectric layers, strip-line, and bottom ground layer can form a vertical sandwich that comprises the flat cable **1306**.

[0119] In one aspect, the ground layers can be comprised of a solid conductor. Alternatively, the ground layers can be configured as a braided wire, or wire thread mesh, comprised of a plurality of thinner wires to form a ground layer. The first ground layer may have a thickness that may be similar or different. In some embodiments, the thickness may range between 10 micrometers (μm) and 100 μm each. A thickness of each individual strand in the braided wire or wire thread mesh may be less than a thickness of a solid conductor. The reduced thickness of each strand can allow the flat cable **1306** to have a shorter bend radius without damaging or kinking the ground layers since the thinner conductors forming the braided wire or wire thread can be bent at a shorter bend radius without significantly changing the impedance or other radio frequency characteristics of the flat cable **1306** relative to a thicker, solid conductor ground layer. The type of braided wire or wire thread mesh can depend on the frequency of the signal traveling over the flat cable **1306**. The braided wire or wire thread mesh can be configured to have through holes that are substantially smaller than a wavelength of the signal. For example, less than $\frac{1}{2}$, $\frac{1}{4}$, $\frac{1}{8}$, or $\frac{1}{16}$ th of the wavelength of the signal traveling over the cable.

[0120] The first ground layer may be formed of a solid flexible conductor. Alternately or additionally, the first ground layer may be formed from a hatched, stranded, or other type of flexible conductor. The conductor types used in the first ground layer may be copper, Kapton, gold, silver, or aluminum, among other types of conductors. The second ground layer may be formed in a manner analogous to the first ground layer with a similar material or the second ground layer may be different from the first ground layer.

[0121] In one aspect, the strip-line may be configured to be approximately centered between the first and second ground layers and approximately centered between lateral edges of the first and second ground layers. Alternately or additionally, the strip-line may be configured to be offset from the center between the first and second ground layers and/or offset from the center between lateral edges of the first and second ground layers. The strip-line may include a conductive material and may be configured to carry a signal through the flat cable **1306**. For example, the conductive material may be copper, Kapton, silver, gold, or aluminum, among

other types of conductive material. In one example embodiment, a conductive tape, such as 3M® 1170, 1181, 1182, 1183, 1190, 1194, or 1245 may be used.

[0122] In one aspect, the strip-line may have a thickness and a width. In some embodiments, the width may be at least twice as large as the thickness. In some embodiments, the width may be such that strip-line electromagnetic field theory may be applied to understand the electromagnetic effect to a signal traversing the strip-line. In some embodiments, the thickness may be between 35 and 150 μm .

[0123] In one aspect, the strip-line may be sized and the conductive material for the strip-line may be selected such that the strip-line provides a particular impedance, such as 50 or 75 ohms. In these and other embodiments, the particular impedance may be selected and the strip-line may be sized and the conductive material selected based on a system within which the flat cable **1306** may be configured to operate. For example, the impedance of the strip-line may be designed to substantially match an impedance of the system within which the flat cable **1306** is configured to operate.

[0124] In one aspect, the strip-line can be configured to carry a direct current (DC) signal and an alternating current (AC) signal. The DC signal may be used to provide power. The AC signal may be used to carry information. In one aspect, the DC signal and/or AC signal can be used to power an active antenna, such as an antenna with an amplifier or other types of powered, active components.

[0125] In one aspect, the strip-line can be formed of a single conductor. The single conductor may be a wire. Alternatively, the strip line can be printed on a surface, such as a surface of a dielectric layer.

[0126] In one aspect, the dielectric material may surround the strip-line to insulate the strip-line from the first and second ground layers. In these and other embodiments, the dielectric material may contact the first and second ground layers and may extend between the lateral edges of the first and second ground layers. The dielectric may be formed of any dielectric material or combination of dielectric materials, including silicon, silicon-oxides, Kapton, and polymers, among other dielectrics. The dielectric material may include a thickness between the first and second ground layers. In some embodiments, multiple layers of dielectric material may be stacked vertically to provide a desired impedance, such as 50 ohms or 75 ohms or another desired impedance. The thickness of each dielectric layer may range between 150 and 1500 μm . In some embodiments, the thickness may be configured such that a minimum distance between the strip-line and either of the first and second ground layers is greater or less than the thickness of the strip-line.

[0127] In one aspect, a thickness of the flat cable **1306** may range between 190 μm and 3000 μm . The flat cable **1306** may also be configured to be flexible. In these and other embodiments, each of the first ground layer, the second ground layer, the dielectric material, the strip-line may be formed of materials and formed in a particular shape and manner such that each of the first ground layer, the second ground layer, the dielectric material, the strip-line may have a stiffness that is within a range of stiffness that would allow a typical person to bend the flat cable **1306** with their hands without using any tools. Furthermore, the combination and arrangement of the first ground layer, the second ground layer, the dielectric material, and the strip-line may be such that the stiffness of the flat cable **1306** is within a range of stiffness that would allow a typical person to bend

the flat cable **1306** with their hands without using any tools. In one example, the flat cable **1306** can be configured to have a bend radius of 10 mm or less.

[0128] In one aspect, the flat cable **1306** can be assembled using an adhesive material to join the first ground layer, the second ground layer, the dielectric material, and the strip-line. The adhesive can be selected based on the components used to form the various materials. The adhesive can be selected to have good radio frequency properties to minimize radio frequency losses within the flat cable **1306**.

[0129] In one aspect, the thickness and flexibility of the flat cable **1306** may allow the flat cable **1306** to be placed between a window and a window sash such that when the window is closed there is a minimum seal gap or minimum change in the ability of the window to close properly. The cable can be configured such that the perpendicular forces and the bending applied to the body of the cable, when the cable is placed between the window and the window sash, will not substantially change a geometry of the body of the cable. Minimizing the change in the geometry of the body when force is applied and bending occurs enables the flat cable **1306** to have substantially the same impedance and radio frequency characteristics.

[0130] In one aspect, if the dimensions of selected layers change, such as the dimensions of the dielectric material changing relative to the dimensions of the strip-line, it can cause changes in impedance in the flat cable **1306**, which can result in a significant impedance loss. A typical round coaxial cable may have its dielectric layer crushed (i.e. reduced in width relative to the center conductor) when the coaxial cable is closed in a window or other type of enclosure, thereby resulting in a significant change in impedance in the coaxial cable. The substantially flat cable **1306** can be enclosed in a window with minimal changes in the geometry of the body, thereby reducing any change in impedance when the window is closed, locked, and/or sealed around the flat cable **1306**.

[0131] For example, in some embodiments, a change in insertion loss can occur for a flat cable, such as flat cable **1306**, that is compressed and/or bent by placing the cable between two surfaces, such as between a window and a window sash, with the window closed or sealed or locked. The insertion loss can be measured at a desired frequency for the flat cable. In some examples, the insertion loss can be measured over a bandwidth of 600 Megahertz (MHz) to 2700 MHz. In other embodiments, the insertion loss can be measured at 500 MHz to 4000 MHz. In one example, insertion loss and return loss can be measured at a center frequency of 2000 MHz over a selected bandwidth.

[0132] The change in insertion loss for the flat cable **1306**, due to bending or compression when the cable is placed between two surfaces, can be from less than 0.1 dB to 1 dB, relative to an insertion loss of the flat cable **1306** when the cable is not compressed or bent by two surfaces, such as the closed window or other type of a threshold.

[0133] The change in impedance or other radio frequency characteristics due to bending and compression can also be measured by a change in return loss. The flat cable **1306** may have a return loss of greater than 10 dB when the cable is not compressed or bent. When the cable is compressed or bent between surfaces, such as the window and the window sash, the return loss may decrease from less than 0.1 dB to 2 db.

[0134] FIG. 14 depicts repeater system, in accordance with another example. In one aspect, the system includes a

first repeater **1402**, a second repeater **1404** and a cable or connector **1406**. The first and second repeaters **1402**, **1404** are adapted for disposition about a structural element **1408**, such as a window, door or similar element. The first repeater **1402** can also be plugged into an electric output of the structure to power the first and second repeaters **1402**, **1404**.

[0135] In one aspect, the first repeater **1402** can include one or more bi-directional amplifiers (BDA) **1410**, and one or more optional transmission antennas **1412**. The one or more transmission antennas **1412** may be integral to the first repeater **1402**, or may be separate from the first repeater **1402**, but removably coupled to the bi-directional amplifier **1410** (e.g., remote external transmission antenna), optionally by one or more wired communication links (e.g., coaxial cable). The one or more bi-directional amplifiers **1410** can function as described above with regard to FIG. 2. Similarly, the second repeater **1404** can include one or more bi-directional amplifiers (BDA) **1414**, and one or more optional transmission antennas **1416**. The one or more transmission antennas **1416** may be integral to the second repeater **1404**, or may be separate from the second repeater **1404**, but removably coupled to the bi-directional amplifier **1414** (e.g., remote external transmission antenna), optionally by one or more wired communication links (e.g., coaxial cable). The one or more bi-directional amplifiers **1414** can function as described above with regard to FIG. 2. The transmission antennas **1412**, **1416** of the first and second repeaters **1402**, **1404** can be directional antennas adapted for fixed structures such as buildings, or an omni-directional antenna for mobile structures such as vehicles.

[0136] In one aspect, the cable or connector **1406** can couple the first and second repeaters **1402**, **1404** through an opening **1418** in the structural element **1408**. In one instance, the opening **1418** can be a hole prefabricated in a structural element **1408** such as a window. In another instance, the opening **1418** can be hole drilled in the structural element **1408** such as a window during the installation of the first and second repeaters **1402**, **1404**. In one instance the opening **1418** that the cable or connector **1406** passes through may be located adjacent to the first and second repeaters **1402**, **1404**. In another instance, the opening **1418** may be located directly between the first and second repeaters **1402**, **1404**, so that the cable or connector **1406** is directly between the first and second repeaters **1402**, **1404**. Accordingly, the repeater system is integrated with a structural element **1408**, such as a window.

[0137] In one aspect, one or more conductive films **1420** may be disposed between the first and second repeaters **1402**, **1404** to improve isolation between the transmission antenna ports. Optionally, one or more thermal or optical coatings applied to the structural element **1408**, such as window glazing, can provide improved isolation between the transmission antenna ports.

[0138] FIG. 15 depicts repeater system, in accordance with another example. In one aspect, the system includes a repeater **1502**, an antenna or passive re-radiation system **1504** and a cable or connector **1506**. The repeater **1502** and antenna **1504** are adapted for disposition about a structural element **1508**, such as a window, door or similar element. The repeater **1502** can also be plugged into an electric output of the structure.

[0139] In one instance, the repeater **1502** can be an inside repeater adapted for placement within a structure, and the antenna or passive re-radiation system **1504** can be adapted

for placement outside the structure attached to a window, wall or the like. In one aspect, the repeater **1502** can include one or more bi-directional amplifiers (BDA) **1510**, and one or more optional transmission antennas **1512**. The one or more transmission antennas **1412** may be integral to the repeater **1402**, or may be separate from the repeater **1402**, but removably coupled to the bi-directional amplifier **1410** (e.g., remote external transmission antenna), optionally by one or more wired communication links (e.g., coaxial cable). The one or more bi-directional amplifiers **1510** can function as described above with regard to FIG. 2.

[0140] In one aspect, the cable or connector **1506** can couple the repeaters **1502** through an opening **1514** in the structural element **1508** to the antenna or passive re-radiation system **1504**. In one instance, the opening **1514** can be a hole prefabricated in a structural element **1508** such as a window. In another instance, the opening **1514** can be hole drilled in the structural element **1508** such as a window during the installation of the repeater **1502** and antenna or passive re-radiation system **1504**. In one instance the opening **1514** that the cable or connector **1506** passed through may be located adjacent to the repeater **1502** and antenna or passive re-radiation system **1504**. In another instance, the opening **1514** may be located directly between the repeater **1402** antenna or passive re-radiation system **1504**, so that the cable or connector **1506** is directly between the repeater **1402** antenna or passive re-radiation system **1504**. Accordingly, the repeater system is integrated with a structural element **1508**, such as a window.

[0141] In one aspect, one or more conductive films **1516** may be disposed between the repeater **1502** and antenna or passive re-radiation system **1504** to improve isolation between the transmission antennas. Optionally, one or more thermal or optical coatings applied to the structural element **1508**, such as window glazing, can provide improved isolation between the transmission antenna.

EXAMPLES

[0142] The following examples pertain to specific technology embodiments and point out specific features, elements, or actions that can be used or otherwise combined in achieving such embodiments.

[0143] Example 1 includes a system comprising: a first repeater including, a first wireless power unit configured to wirelessly transmit a portion of Direct Current (DC) or Alternating Current (AC) electrical power received from a power source; and a first bi-directional amplifier, configured to amplify one or more RF communication signals, wherein the first bi-directional amplifier is powered by the power source; and a second repeater including, a second wireless power unit configured to receive the wireless power, and convert the wireless power to DC or AC electrical power, and a second bi-directional amplifier, configured to amplify the one or more RF communication signals, wherein the second bi-directional amplifier is powered by the DC or AC electrical power from the second wireless power unit.

[0144] Example 2 includes the system of Example 1, wherein, the first wireless power unit includes, a wireless power transmitter configured to convert the portion of DC or AC electrical power received from the power source to a RF power signal; and a first power coupler, coupled to the wireless power transmitter, configured to transmit the RF power signal; the second wireless power unit includes, a second power coupler configured to receive the RF power

signal; and a wireless power receiver, coupled to the second power coupler, configured to convert the received RF power signal to the DC or AC electrical power.

[0145] Example 3 includes the system of Example 2, wherein, the first power coupler includes an inductive coil; and the second power coupler include an inductive coil.

[0146] Example 4 includes the system of Example 2, wherein, the first power coupler includes a capacitive electrode; and the second power coupler include a capacitive electrode.

[0147] Example 5 includes the system of Example 1, wherein, the first wireless power unit includes an optical power transmitter configured to convert the portion of DC or AC electrical power received from the power source to an optical signal and transmit the optical signal; and the second wireless power unit includes an optical power receiver configured to receive the optical signal and convert the optical signal to the DC or AC electrical power.

[0148] Example 6 includes the system of Example 1, further comprising: the first repeater further including, a first RF coupling antenna coupled to the first bi-directional amplifier; the second repeater further including, a second RF coupling antenna coupled to the second bi-directional amplifier.

[0149] Example 7 includes the system of Example 6, further comprising: a conductive film configured to be disposed between the first repeater and the second repeater.

[0150] Example 8 includes the system of Example 6, further comprising: a conductive film including one or more openings configured to be disposed between the first RF coupling antenna of the first repeater and the second RF coupling antenna of the second repeater and between the first wireless power unit and the second wireless power unit.

[0151] Example 9 includes the system of Examples 7 or 8, wherein the conductive film is transparent.

[0152] Example 10 includes the system of Examples 7 or 8, wherein the conductive film comprises a film of thin metal wires.

[0153] Example 11 includes the system of Example 1, further comprising: a third repeater communicatively coupled to the first repeater by a wired communication link.

[0154] Example 12 includes the system of Example 1, further comprising: the first repeater further including, a first transmission antenna coupled to a transmission port of the first bi-directional amplifier; the second repeater further including, a second transmission antenna coupled to a transmission port of the second bi-directional amplifier.

[0155] Example 13 includes the system of Example 1, wherein, the first transmission antenna is a directional antenna; and the second transmission antenna is a directional antenna.

[0156] Example 14 includes the system of Example 1, wherein, the first transmission antenna is an omni-directional antenna; and the second transmission antenna is a directional antenna.

[0157] Example 15 includes the system of Example 1, wherein, the first repeater comprises a first Single-Input-Single-Output (SISO) repeater; and the second repeater comprises a second SISO repeater.

[0158] Example 16 includes the system of Example 1, wherein the first bi-directional amplifier is configured to compensate for RF transmission loss across a structural element disposed between the first and second repeaters.

[0159] Example 17 includes the system of Example 1, wherein the second bi-directional amplifier is configured to compensate for RF transmission loss across a structural element disposed between the first and second repeaters.

[0160] Example 18 includes a system comprising: a first repeater including, a wireless power transmitter configured to convert a portion of Direct Current (DC) or Alternating Current (AC) electrical power received from a power source to a RF power signal; a first power coupler, coupled to the wireless power transmitter, configured to transmit the RF power signal; a first RF coupling antenna; a first bi-directional amplifier, coupled to the first RF coupling antenna and configured to amplify one or more RF communication signals, wherein the first bi-directional amplifier is powered by the power source; and a second repeater including, a second power coupled configured to receive the RF power signal; a wireless power receiver configured convert the received RF power signal to DC or AC electrical power; a second RF coupling antenna; and a second bi-directional amplifier, coupled to the second RF coupling antenna and configured to amplify the one or more RF communication signals, wherein the second bi-directional amplifier is powered by the DC or AC electrical power from the wireless power receiver.

[0161] Example 19 includes the system of Example 18, wherein, the first power coupler includes an inductive coil; and the second power coupler includes an inductive coil.

[0162] Example 20 includes the system of Example 18, wherein, the first power coupler includes a capacitive electrode; and the second power coupler include a capacitive electrode.

[0163] Example 21 includes the system of Example 18, further comprising: a conductive film including one or more openings configured to be disposed between the first RF coupling antenna of the first repeater and the second RF coupling antenna of the second repeater, and between first power coupler and the second power coupler.

[0164] Example 22 includes the system of Example 18, further comprising: a first transmission antenna coupled to the first bi-directional amplifier, wherein the first transmission antenna is a directional antenna internally integral to the first repeater; and a second transmission antenna couple to the second bi-direction amplifier, wherein the second transmission antenna is an omni-directional antenna externally integral to the first repeater.

[0165] Example 23 includes a system comprising: a first repeater including, an optical power transmitter configured to convert a portion of Direct Current (DC) or Alternating Current (AC) electrical power received from a power source to an optical signal and transmit the optical signal; a first RF coupling antenna; and a first bi-directional amplifier, coupled to the first RF coupling antenna and configured to amplify one or more RF communication signals, wherein the first bi-directional amplifier is powered by the power source; and a second repeater including, an optical power receiver configured to receive the optical signal, and convert the optical signal to DC or AC electrical power; a second RF coupling antenna; and a second bi-directional amplifier, coupled to the second RF coupling antenna and configured to amplify the one or more RF communication signals, wherein the second bi-directional amplifier is powered by the DC or AC electrical power from the second wireless power unit.

[0166] Example 24 includes the system of Example 23, further comprising: one or more processors and memory configured to: configure the optical power transmitter to initially transmit at a predetermined low power level; determine if the optical power receiver is aligned with the optical power transmitter to receive the optical signal; configure the optical power transmitter to transmit at a predetermined high power level if the optical power receiver is determined to be aligned with the optical power transmitter to receive the optical signal.

[0167] Example 25 includes the system of Example 23, further comprising: a conductive film including one or more openings configured to be disposed between the first RF coupling antenna of the first repeater and the second RF coupling antenna of the second repeater, and between optical power transmitter and the optical power receiver.

[0168] Example 26 includes the system of Example 23, further comprising: a first transmission antenna coupled to the first bi-directional amplifier, wherein the first transmission antenna is a directional antenna internally integral to the first repeater; and a second transmission antenna couple to the second bi-direction amplifier, wherein the second transmission antenna is an omni-directional antenna externally integral to the first repeater.

[0169] Example 27 includes a system comprising: a first wireless power unit configured to convert a portion of Direct Current (DC) or Alternating Current (AC) electrical power received from a power source to wireless power and wirelessly transmit the wireless power; a first repeater including a first bi-directional amplifier, configured to amplify one or more RF communication signals, wherein the first bi-directional amplifier is powered by the power source; a second wireless power unit configured to receive the wireless power, and convert the wireless power to DC or AC electrical power; and a second repeater including a second bi-directional amplifier, configured to amplify the one or more RF communication signals, wherein the second bi-directional amplifier is powered by the DC or AC electrical power from the second wireless power unit.

[0170] Example 28 includes the system of Example 27, wherein, the first wireless power unit includes, a wireless power transmitter configured to convert the portion of DC or AC electrical power received from the power source to a RF power signal; and a first power coupler, coupled to the wireless power transmitter, configured to transmit the RF power signal; the second wireless power unit includes, a second power coupler configured to configured to receive the RF power signal; and a wireless power receiver, coupled to the second power coupler, configured to convert the received RF power signal to the DC or AC electrical power.

[0171] Example 29 includes the system of Example 27, wherein, the first wireless power unit includes an optical power transmitter configured to convert the portion of DC or AC electrical power received from the power source to an optical signal and transmit the optical signal; and the second wireless power unit includes an optical power receiver configured to receive the optical signal and convert the optical signal to the DC or AC electrical power.

[0172] Example 30 includes a system comprising: a first repeater disposed outside a structure and configured to amplify one or more RF communication signals, wherein the first repeater is coupled to power outside the structure; and a second repeater disposed inside the structure and config-

ured to amplify the one or more RF communication signals, wherein the second repeater is coupled to power inside the structure.

[0173] Example 31 includes the system of Example 30, wherein the first repeater is configured to compensate for RF transmission loss across a structural element disposed between the first and second repeaters.

[0174] Example 32 includes the system of Example 30, wherein the second repeater is configured to compensate for RF transmission loss across a structural element disposed between the first and second repeaters.

[0175] Example 33 includes the system of Example 30, further comprising: a conductive film including one or more openings configured to be disposed between the first repeater and the second repeater.

[0176] Example 34 includes the system of Example 33, wherein the conductive film is transparent.

[0177] Example 35 includes the system of Example 33, wherein the conductive film comprises a film of thin metal wires.

[0178] Example 36 includes a system comprising: a first repeater disposed outside a structure and configured to amplify one or more RF communication signals, wherein the first repeater is powered by a solar panel; and a second repeater disposed inside the structure and configured to amplify the one or more RF communication signals, wherein the second repeater is powered by a source inside the structure.

[0179] Example 37 includes the system of Example 36, wherein the first repeater is configured to compensate for RF transmission loss across a structural element disposed between the first and second repeaters.

[0180] Example 38 includes the system of Example 36, wherein the second repeater is configured to compensate for RF transmission loss across a structural element disposed between the first and second repeaters.

[0181] Example 39 includes the system of Example 36, further comprising: a conductive film including one or more openings configured to be disposed between the first repeater and the second repeater.

[0182] Example 40 includes the system of Example 39, wherein the conductive film is transparent.

[0183] Example 41 includes the system of Example 39, wherein the conductive film comprises a film of thin metal wires.

[0184] Example 42 includes a system comprising: a first repeater including, an optical power transmitter configured to convert a portion of Direct Current (DC) or Alternating Current (AC) electrical power received from a power source to an optical signal and transmit the optical signal; a first optical signal transceiver; a first bi-directional amplifier configured to amplify one or more RF communication signals, wherein the first bi-directional amplifier is powered by the power source; and a first RF-optical converter, coupled between the first optical signal transceiver and the first bi-directional amplifier, and configured to convert the one or more RF communication signals from the first bi-directional amplifier to one or more optical communication signals for the first optical signal transceiver; and a second repeater including, an optical power receiver configured to receive the optical signal, and convert the optical signal to DC or AC electrical power; a second optical signal transceiver; a second bi-directional amplifier configured to amplify the one or more RF communication signals, wherein

the second bi-directional amplifier is powered by the DC or AC electrical power from the second wireless power unit; and a second RF-optical converter, coupled between the second optical signal transceiver and the second bi-directional amplifier, and configured to convert the one or more optical communication signals from the second optical signal transceiver to one or more RF communication signals for the second bi-directional amplifier.

[0185] Example 43 includes the system of Example 42, wherein; the first RF-optical converter is further configured to convert the one or more optical communication signals from the first optical signal transceiver to the one or more RF communication signals for the first bi-directional amplifier; and the second RF-optical converter is further configured to convert the one or more RF communication signal from the second bi-directional amplifier to the one or more optical communication signals for the second optical signal transceiver.

[0186] Example 44 includes the system of Example 42, further comprising: a first transmission antenna coupled to the first bi-directional amplifier, wherein the first transmission antenna is a directional antenna internally integral to the first repeater; and a second transmission antenna couple to the second bi-direction amplifier, wherein the second transmission antenna is an omni-directional antenna externally integral to the first repeater.

[0187] Example 45 includes a system comprising: a transmission antenna; a repeater including a bi-directional amplifier, coupled to the transmission antenna configured to amplify one or more RF communication signals; an antenna; and a flat cable coupled between the bi-directional amplifier and the antenna.

[0188] Example 46 includes the system of Example 45, wherein the repeater and the antenna are mount on either side of a structural element as a closely-contained system.

[0189] Example 47 includes the system of Example 45, wherein the flat cable comprises: a first ground layer; a second ground layer; a strip-line positioned between the first ground layer and the second ground layer; and a dielectric material positioned between the first ground layer and the second ground layer and surrounding the strip-line to insulate the strip-line from the first ground layer and the second ground layer.

[0190] Example 48 includes the system of Example 45, wherein the transmission antenna comprises an omni-directional antenna integral to the repeater.

[0191] Example 49 includes the system of Example 45, wherein the transmission antenna comprises an omni-directional antenna removably coupled to the bi-directional amplifier.

[0192] Example 50 includes the system of Example 45, wherein the antenna comprises a directional antenna configured to attach to a structural element.

[0193] Example 51 includes the system of Example 45, wherein the antenna comprises an omni-directional antenna configured to be attached to a structural element.

[0194] Example 52 includes the system of Example 45, wherein the antenna is a passive antenna.

[0195] Example 53 includes the system of Example 45, wherein the antenna is an active antenna that receives power from the flat cable.

[0196] Example 54 includes a system comprising: a first repeater; a second repeater; a cable or connector coupled between the first repeater and the second repeater through an

opening in a structural element that the first repeater and second repeater are attached to.

[0197] Example 55 includes the system of Example 54, wherein the opening in the structural element is prefabricated into the structural element.

[0198] Example 56 includes the system of Example 54, wherein the opening in the structural element is fabricated into the structural element when the repeater and antenna are installed on the structural element.

[0199] Example 57 includes the system of Example 54, wherein the structural element includes a window and the opening is a hole prefabricated in the window.

[0200] Example 58 includes the system of Example 54, wherein the structural element includes a window and the opening is a hole fabricated in the window when the repeater and antenna are installed on the window.

[0201] Example 59 includes the system of Example 54, further comprising a conductive film configured to be disposed between the first repeater and the second repeater.

[0202] Example 60 includes a system comprising: a transmission antenna; a repeater including a bi-directional amplifier, coupled to the transmission antenna configured to amplify one or more RF communication signals; an antenna; and a cable or connector coupled between the bi-directional amplifier and the antenna through an opening in a structural element that the antenna and repeater are attached to.

[0203] Example 61 includes the system of Example 60, wherein the opening in the structural element is prefabricated into the structural element.

[0204] Example 62 includes the system of Example 60, wherein the opening in the structural element is fabricated into the structural element when the repeater and antenna are installed on the structural element.

[0205] Example 63 includes the system of Example 60, wherein the structural element includes a window and the opening is a hole prefabricated in the window.

[0206] Example 64 includes the system of Example 60, wherein the structural element includes a window and the opening is a hole fabricated in the window when the repeater and antenna are installed on the window.

[0207] Example 65 includes the system of Example 60, further comprising a conductive film configured to be disposed between the first repeater and the second repeater.

[0208] Example 66 includes a system comprising: a first repeater including, a first wireless power unit having a first wireless power coupler configured to wirelessly transmit a portion of Direct Current (DC) or Alternating Current (AC) electrical power received from a power source; and a first bi-directional amplifier, configured to amplify one or more RF communication signals, wherein the first bi-directional amplifier is powered by the power source; a second repeater including, a second wireless power unit having a second wireless power coupler configured to receive the wireless power, and the second wireless power unit is configured to convert the wireless power to DC or AC electrical power, and a second bi-directional amplifier, configured to amplify the one or more RF communication signals, wherein the second bi-directional amplifier is powered by the DC or AC electrical power from the second wireless power unit; a structural element disposed between the first repeater and the second repeater; and a conductive material integral to the structural element configured to be disposed between the first repeater and the second repeater, wherein the conductive material includes one or more openings configured to be

disposed between the first wireless power coupler and the second wireless power coupler.

[0209] Example 67 includes the system of Example 66, wherein the conductive material comprises one or more of a film, a glazing, or a wired mesh.

[0210] Example 68 includes the system of Example 66, wherein, the first wireless power unit includes, a wireless power transmitter configured to convert the portion of DC or AC electrical power received from the power source to a RF power signal; and the first power coupler, coupled to the wireless power transmitter, configured to transmit the RF power signal; the second wireless power unit includes, the second power coupler configured to receive the RF power signal; and a wireless power receiver, coupled to the second power coupler, configured to convert the received RF power signal to the DC or AC electrical power.

[0211] Example 69 includes the system of Example 68, wherein, the first power coupler includes an inductive coil or a capacitive electrode; and the second power coupler includes an inductive coil or a capacitive electrode.

[0212] Example 70 includes the system of Example 66, further comprising: a first shielding path between the first power coupler and the structural element; and a second shielding path between the second power coupler and the structural element.

[0213] Example 71 includes the system of Example 70, wherein the first shielding path and the second shielding path have a substantially similar shape as the opening disposed between the first wireless power coupler and the second wireless power coupler to form a communication path between the first power coupler and the second power coupler.

[0214] Example 72 includes the system of claim 66, wherein, the first wireless power unit includes an optical power transmitter configured to convert the portion of DC or AC electrical power received from the power source to an optical signal and transmit the optical signal; and the second wireless power unit includes an optical power receiver configured to receive the optical signal and convert the optical signal to the DC or AC electrical power.

[0215] Example 73 includes the system of Example 66, further comprising: the first repeater further including, a first RF coupling antenna coupled to the first bi-directional amplifier; the second repeater further including, a second RF coupling antenna coupled to the second bi-directional amplifier.

[0216] Example 74 includes the system of Example 73, wherein the conductive material includes one or more openings configured to be disposed between the first RF coupling antenna and the second RF coupling antenna.

[0217] Example 75 includes the system of Example 74, further comprising: a first shielding path between the first RF coupling antenna and the structural element; and a second shielding path between the second RF coupling antenna and the structural element.

[0218] Example 76 includes the system of Example 75, wherein the first shielding path and the second shielding path have a substantially similar shape as the opening disposed between the first RF coupling antenna and the second RF coupling antenna to form a communication path between the first RF coupling antenna and the second RF coupling antenna.

[0219] Example 77 includes the system of Example 66, wherein the conductive material is attached to a structural element disposed between the first repeater and the second repeater.

[0220] Example 78 includes the system of Example 66, wherein the conductive material is substantially transparent.

[0221] Example 79 includes the system of Example 66, wherein the conductive material comprises a material of thin metal wires.

[0222] Example 80 includes the system of Example 66, further comprising: the first repeater further including, a first transmission antenna coupled to a transmission port of the first bi-directional amplifier; the second repeater further including, a second transmission antenna coupled to a transmission port of the second bi-directional amplifier.

[0223] Example 81 includes the system of Example 66, wherein, the first transmission antenna is a directional antenna; and the second transmission antenna is a directional antenna.

[0224] Example 82 includes the system of Example 66, wherein, the first transmission antenna is an omni-directional antenna; and the second transmission antenna is a directional antenna.

[0225] Example 83 includes the system of Example 66, wherein, the first repeater comprises a first Single-Input-Single-Output (SISO) repeater; and the second repeater comprises a second SISO repeater.

[0226] Example 84 includes the system of Example 66, wherein the first bi-directional amplifier is configured to compensate for RF transmission loss across a structural element disposed between the first and second repeaters.

[0227] Example 85 includes the system of Example 66, wherein the second bi-directional amplifier is configured to compensate for RF transmission loss across a structural element disposed between the first and second repeaters.

[0228] Example 86 includes a system comprising: a first repeater including, an optical power transmitter configured to convert a portion of Direct Current (DC) or Alternating Current (AC) electrical power received from a power source to an optical signal and transmit the optical signal; a first RF coupling antenna; and a first bi-directional amplifier, coupled to the first RF coupling antenna and configured to amplify one or more RF communication signals, wherein the first bi-directional amplifier is powered by the power source; and a second repeater including, an optical power receiver configured to receive the optical signal, and convert the optical signal to DC or AC electrical power; a second RF coupling antenna; and a second bi-directional amplifier, coupled to the second RF coupling antenna and configured to amplify the one or more RF communication signals, wherein the second bi-directional amplifier is powered by the DC or AC electrical power from the second wireless power unit.

[0229] Example 87 includes the system of Example 86, further comprising: a conductive material configured to be disposed between the first repeater and the second wireless repeater.

[0230] Example 88 includes the system of Example 86, further comprising: one or more processors and memory configured to: configure the optical power transmitter to initially transmit at a predetermined low power level; determine if the optical power receiver is aligned with the optical power transmitter to receive the optical signal; configure the optical power transmitter to transmit at a predetermined high

power level if the optical power receiver is determined to be aligned with the optical power transmitter to receive the optical signal.

[0231] Example 89 includes the system of Example 86, wherein the conductive material includes one or more openings configured to be disposed between the first RF coupling antenna of the first repeater and the second RF coupling antenna of the second repeater, and between optical power transmitter and the optical power receiver.

[0232] Example 90 includes the system of Example 86, further comprising: a first transmission antenna coupled to the first bi-directional amplifier, wherein the first transmission antenna is a directional antenna internally integral to the first repeater; and a second transmission antenna coupled to the second bi-directional amplifier, wherein the second transmission antenna is an omni-directional antenna externally integral to the first repeater.

[0233] Example 91 includes a system comprising: a first wireless relay including, a first transmission antenna; a first RF coupling antenna; and a first repeater coupled to the first RF coupling antenna and configured to amplify one or more RF communication signals; a second wireless relay including, a second transmission antenna, a second RF coupling antenna; and a second repeater coupled to the second RF coupling antenna and configured to amplify the one or more RF communication signals; and a conductive material configured to be disposed between the first wireless relay and the second wireless relay.

[0234] Example 92 includes the system of Example 91, wherein the conductive material is integral to a structural element disposed between the first wireless relay and the second wireless relay.

[0235] Example 93 includes the system of Example 92, wherein an opening in the structural element is prefabricated into the structural element.

[0236] Example 94 includes the system of Example 92, wherein an opening in the structural element is fabricated into the structural element when the repeater and antenna are installed on the structural element.

[0237] Example 95 includes the system of Example 92, wherein the structural element includes a window and an opening is a hole prefabricated in the window.

[0238] Example 96 includes the system of Example 92, wherein the structural element includes a window and an opening is a hole fabricated in the window when the repeater and antenna are installed on the window.

[0239] Example 97 includes the system of Example 91, wherein the conductive material includes one or more openings configured to be disposed between the first RF coupling antenna of the first wireless relay and the second RF coupling antenna of the second wireless relay.

[0240] Example 98 includes the system of Example 91, wherein the conductive material is substantially transparent.

[0241] Example 99 includes the system of Example 91, wherein the conductive material comprises thin metal wires.

[0242] Example 100 includes the system of Example 91, further comprising: the first wireless relay further including, the first transmission antenna coupled to a transmission port of the first repeater; the second wireless relay further including, the second transmission antenna coupled to a transmission port of the second repeater.

[0243] Example 101 includes the system of Example 91, wherein, the first transmission antenna is a directional antenna; and the second transmission antenna is a directional antenna.

[0244] Example 102 includes the system of Example 91, wherein, the first transmission antenna is an omni-directional antenna; and the second transmission antenna is a directional antenna.

[0245] Example 103 includes the system of Example 91, wherein, the first wireless relay comprises a first Single-Input-Single-Output (SISO) repeater; and the second wireless relay comprises a second SISO repeater.

[0246] Example 104 includes the system of Example 91, wherein the first repeater is configured to compensate for RF transmission loss across a structural element disposed between the first and second wireless relays.

[0247] Example 105 includes the system of Example 91, wherein the second repeater is configured to compensate for RF transmission loss across a structural element disposed between the first and second wireless relays.

[0248] As used herein, the term “circuitry” may refer to, be part of, or include an Application Specific Integrated Circuit (ASIC), an electronic circuit, a processor (shared, dedicated, or group), and/or memory (shared, dedicated, or group) that execute one or more software or firmware programs, a combinational logic circuit, and/or other suitable hardware components that provide the described functionality. In some aspects, the circuitry may be implemented in, or functions associated with the circuitry may be implemented by, one or more software or firmware modules. In some aspects, circuitry may include logic, at least partially operable in hardware.

[0249] Various techniques, or certain aspects or portions thereof, may take the form of program code (i.e., instructions) embodied in tangible media, such as floppy diskettes, compact disc-read-only memory (CD-ROMs), hard drives, transitory or non-transitory computer readable storage medium, or any other machine-readable storage medium wherein, when the program code is loaded into and executed by a machine, such as a computer, the machine becomes an apparatus for practicing the various techniques. Circuitry may include hardware, firmware, program code, executable code, computer instructions, and/or software. A non-transitory computer readable storage medium may be a computer readable storage medium that does not include signal. In the case of program code execution on programmable computers, the computing device may include a processor, a storage medium readable by the processor (including volatile and non-volatile memory and/or storage elements), at least one input device, and at least one output device. The volatile and non-volatile memory and/or storage elements may be a random-access memory (RAM), erasable programmable read only memory (EPROM), flash drive, optical drive, magnetic hard drive, solid state drive, or other medium for storing electronic data. The node and wireless device may also include a transceiver module (i.e., transceiver), a counter module (i.e., counter), a processing module (i.e., processor), and/or a clock module (i.e., clock) or timer module (i.e., timer). One or more programs that may implement or utilize the various techniques described herein may use an application programming interface (API), reusable controls, and the like. Such programs may be implemented in a high level procedural or object oriented programming language to communicate with a computer system. However, the pro-

gram(s) may be implemented in assembly or machine language, if desired. In any case, the language may be a compiled or interpreted language, and combined with hardware implementations.

[0250] As used herein, the term processor may include general purpose processors, specialized processors such as VLSI, FPGAs, or other types of specialized processors, as well as base band processors used in transceivers to send, receive, and process wireless communications.

[0251] It should be understood that many of the functional units described in this specification have been labeled as modules, in order to more particularly emphasize their implementation independence. For example, a module may be implemented as a hardware circuit comprising custom very-large-scale integration (VLSI) circuits or gate arrays, off-the-shelf semiconductors such as logic chips, transistors, or other discrete components. A module may also be implemented in programmable hardware devices such as field programmable gate arrays, programmable array logic, programmable logic devices or the like.

[0252] Modules may also be implemented in software for execution by various types of processors. An identified module of executable code may, for instance, comprise one or more physical or logical blocks of computer instructions, which may, for instance, be organized as an object, procedure, or function. Nevertheless, the executables of an identified module cannot be physically located together, but may comprise disparate instructions stored in different locations which, when joined logically together, comprise the module and achieve the stated purpose for the module.

[0253] Indeed, a module of executable code may be a single instruction, or many instructions, and may even be distributed over several different code segments, among different programs, and across several memory devices. Similarly, operational data may be identified and illustrated herein within modules, and may be embodied in any suitable form and organized within any suitable type of data structure. The operational data may be collected as a single data set, or may be distributed over different locations including over different storage devices, and may exist, at least partially, merely as electronic signals on a system or network. The modules may be passive or active, including agents operable to perform desired functions.

[0254] Reference throughout this specification to “an example” or “exemplary” means that a particular feature, structure, or characteristic described in connection with the example is included in at least one embodiment of the present technology. Thus, appearances of the phrases “in an example” or the word “exemplary” in various places throughout this specification are not necessarily all referring to the same embodiment.

[0255] As used herein, a plurality of items, structural elements, compositional elements, and/or materials may be presented in a common list for convenience. However, these lists should be construed as though each member of the list is individually identified as a separate and unique member. Thus, no individual member of such list should be construed as a de facto equivalent of any other member of the same list solely based on their presentation in a common group without indications to the contrary. In addition, various embodiments and example of the present technology may be referred to herein along with alternatives for the various components thereof. It is understood that such embodiments, examples, and alternatives are not to be construed as de facto

equivalents of one another, but are to be considered as separate and autonomous representations of the present technology.

[0256] Furthermore, the described features, structures, or characteristics may be combined in any suitable manner in one or more embodiments. In the following description, numerous specific details are provided, such as examples of layouts, distances, network examples, etc., to provide a thorough understanding of embodiments of the technology. One skilled in the relevant art will recognize, however, that the technology may be practiced without one or more of the specific details, or with other methods, components, layouts, etc. In other instances, well-known structures, materials, or operations are not shown or described in detail to avoid obscuring aspects of the technology.

[0257] While the forgoing examples are illustrative of the principles of the present technology in one or more particular applications, it will be apparent to those of ordinary skill in the art that numerous modifications in form, usage and details of implementation may be made without the exercise of inventive faculty, and without departing from the principles and concepts of the technology. Accordingly, it is not intended that the technology be limited, except as by the claims set forth below.

What is claimed is:

1. A system comprising:
 - a first repeater including,
 - a first wireless power unit having a first wireless power coupler configured to wirelessly transmit a portion of Direct Current (DC) or Alternating Current (AC) electrical power received from a power source; and
 - a first bi-directional amplifier, configured to amplify one or more RF communication signals, wherein the first bi-directional amplifier is powered by the power source;
 - a second repeater including,
 - a second wireless power unit having a second wireless power coupler configured to receive the wireless power, and the second wireless power unit is configured to convert the wireless power to DC or AC electrical power, and
 - a second bi-directional amplifier, configured to amplify the one or more RF communication signals, wherein the second bi-directional amplifier is powered by the DC or AC electrical power from the second wireless power unit;
 - a structural element disposed between the first repeater and the second repeater; and a conductive material integral to the structural element configured to be disposed between the first repeater and the second repeater, wherein the conductive material includes one or more openings configured to be disposed between the first wireless power coupler and the second wireless power coupler.
2. The system of claim 1, wherein the conductive material comprises one or more of a film, a glazing, or a wired mesh.
3. The system of claim 1, wherein,
 - the first wireless power unit includes,
 - a wireless power transmitter configured to convert the portion of DC or AC electrical power received from the power source to a RF power signal; and
 - the first power coupler, coupled to the wireless power transmitter, configured to transmit the RF power signal;

the second wireless power unit includes,

- the second power coupler configured to receive the RF power signal; and
 - a wireless power receiver, coupled to the second power coupler,
 - configured to convert the received RF power signal to the DC or AC electrical power.
4. The system of claim 3, wherein,
 - the first power coupler includes an inductive coil or a capacitive electrode; and
 - the second power coupler includes an inductive coil or a capacitive electrode.
 5. The system of claim 1, further comprising:
 - a first shielding path between the first power coupler and the structural element; and
 - a second shielding path between the second power coupler and the structural element.
 6. The system of claim 5, wherein the first shielding path and the second shielding path have a substantially similar shape as the opening disposed between the first wireless power coupler and the second wireless power coupler to form a communication path between the first power coupler and the second power coupler.
 7. The system of claim 1, wherein,
 - the first wireless power unit includes an optical power transmitter configured to convert the portion of DC or AC electrical power received from the power source to an optical signal and transmit the optical signal; and
 - the second wireless power unit includes an optical power receiver configured to receive the optical signal and convert the optical signal to the DC or AC electrical power.
 8. The system of claim 1, further comprising:
 - the first repeater further including,
 - a first RF coupling antenna coupled to the first bi-directional amplifier;
 - the second repeater further including,
 - a second RF coupling antenna coupled to the second bi-directional amplifier.
 9. The system of claim 8, wherein the conductive material includes one or more openings configured to be disposed between the first RF coupling antenna and the second RF coupling antenna.
 10. The system of claim 9, further comprising:
 - a first shielding path between the first RF coupling antenna and the structural element; and
 - a second shielding path between the second RF coupling antenna and the structural element.
 11. The system of claim 10, wherein the first shielding path and the second shielding path have a substantially similar shape as the opening disposed between the first RF coupling antenna and the second RF coupling antenna to form a communication path between the first RF coupling antenna and the second RF coupling antenna.
 12. The system of claim 1, wherein the conductive material is attached to a structural element disposed between the first repeater and the second repeater.
 13. The system of claim 1, wherein the conductive material is substantially transparent.

14. The system of claim **1**, wherein the conductive material comprises a material comprised of thin metal wires.

15. The system of claim **1**, further comprising:
the first repeater further including,
a first transmission antenna coupled to a transmission port
of the first bi-directional amplifier;
the second repeater further including,
a second transmission antenna coupled to a transmission
port of the second bi-directional amplifier.

16. The system of claim **1**, wherein,
the first transmission antenna is a directional antenna; and
the second transmission antenna is a directional antenna.

17. The system of claim **1**, wherein,
the first transmission antenna is an omni-directional
antenna; and
the second transmission antenna is a directional antenna.

18. The system of claim **1**, wherein,
the first repeater comprises a first Single-Input-Single-
Output (SISO) repeater; and
the second repeater comprises a second SISO repeater.

19. The system of claim **1**, wherein the first bi-directional amplifier is configured to compensate for RF transmission loss across a structural element disposed between the first and second repeaters.

20. The system of claim **1**, wherein the second bi-directional amplifier is configured to compensate for RF transmission loss across a structural element disposed between the first and second repeaters.

* * * * *