



(19) **United States**

(12) **Patent Application Publication**

Wang et al.

(10) **Pub. No.: US 2020/0243455 A1**

(43) **Pub. Date: Jul. 30, 2020**

(54) **HYBRID BONDING USING DUMMY BONDING CONTACTS AND DUMMY INTERCONNECTS**

*H01L 21/768* (2006.01)  
*H01L 27/1157* (2006.01)  
*H01L 27/11582* (2006.01)

(71) Applicant: **YANGTZE MEMORY TECHNOLOGIES CO., LTD.**, Wuhan (CN)

(52) **U.S. Cl.**  
CPC .... *H01L 23/53238* (2013.01); *H01L 23/5384* (2013.01); *H01L 24/19* (2013.01); *H01L 27/11582* (2013.01); *H01L 24/06* (2013.01); *H01L 21/76841* (2013.01); *H01L 27/1157* (2013.01); *H01L 24/20* (2013.01)

(72) Inventors: **Tao Wang**, Wuhan (CN); **Si Ping Hu**, Wuhan (CN); **Jia Wen Wang**, Wuhan (CN); **Shi Qi Huang**, Wuhan (CN); **Jifeng Zhu**, Wuhan (CN); **Jun Chen**, Wuhan (CN); **Zi Qun Hua**, Wuhan (CN)

(57) **ABSTRACT**

Embodiments of bonded semiconductor structures and fabrication methods thereof are disclosed. In an example, a semiconductor device includes a first and a second semiconductor structures. The first semiconductor structure includes a first interconnect layer including first interconnects. At least one first interconnect is a first dummy interconnect. The first semiconductor structure further includes a first bonding layer including first bonding contacts. Each first interconnect is in contact with a respective first bonding contact. The second semiconductor structure includes a second interconnect layer including second interconnects. At least one second interconnect is a second dummy interconnect. The second semiconductor structure further includes a second bonding layer including second bonding contacts. Each second interconnect is in contact with a respective second bonding contact. The semiconductor device further includes a bonding interface between the first and second bonding layers. Each first bonding contact is in contact with a respective second bonding contact at the bonding interface.

(73) Assignee: **Yangtze Memory Technologies Co., Ltd.**

(21) Appl. No.: **16/292,279**

(22) Filed: **Mar. 4, 2019**

**Related U.S. Application Data**

(63) Continuation of application No. PCT/CN2019/073909, filed on Jan. 30, 2019.

**Publication Classification**

(51) **Int. Cl.**  
*H01L 23/532* (2006.01)  
*H01L 23/538* (2006.01)  
*H01L 23/00* (2006.01)

**300**

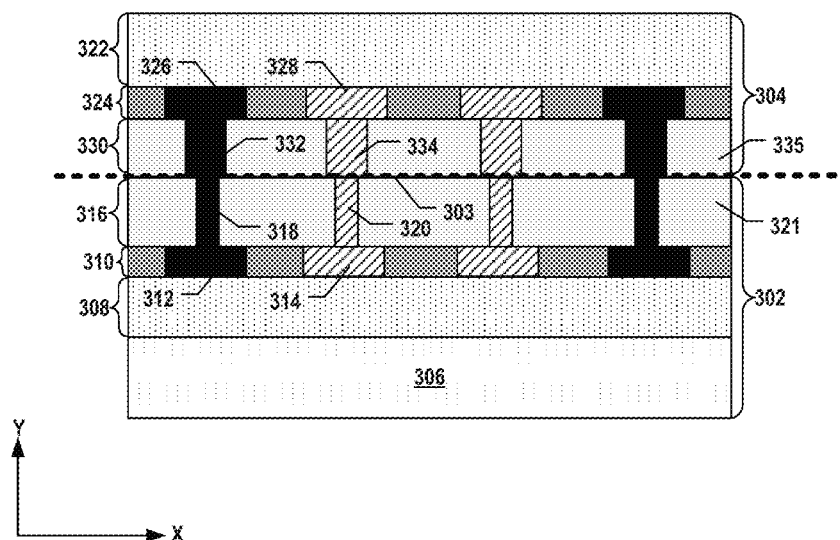

100

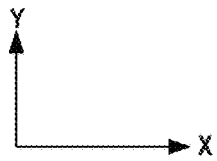
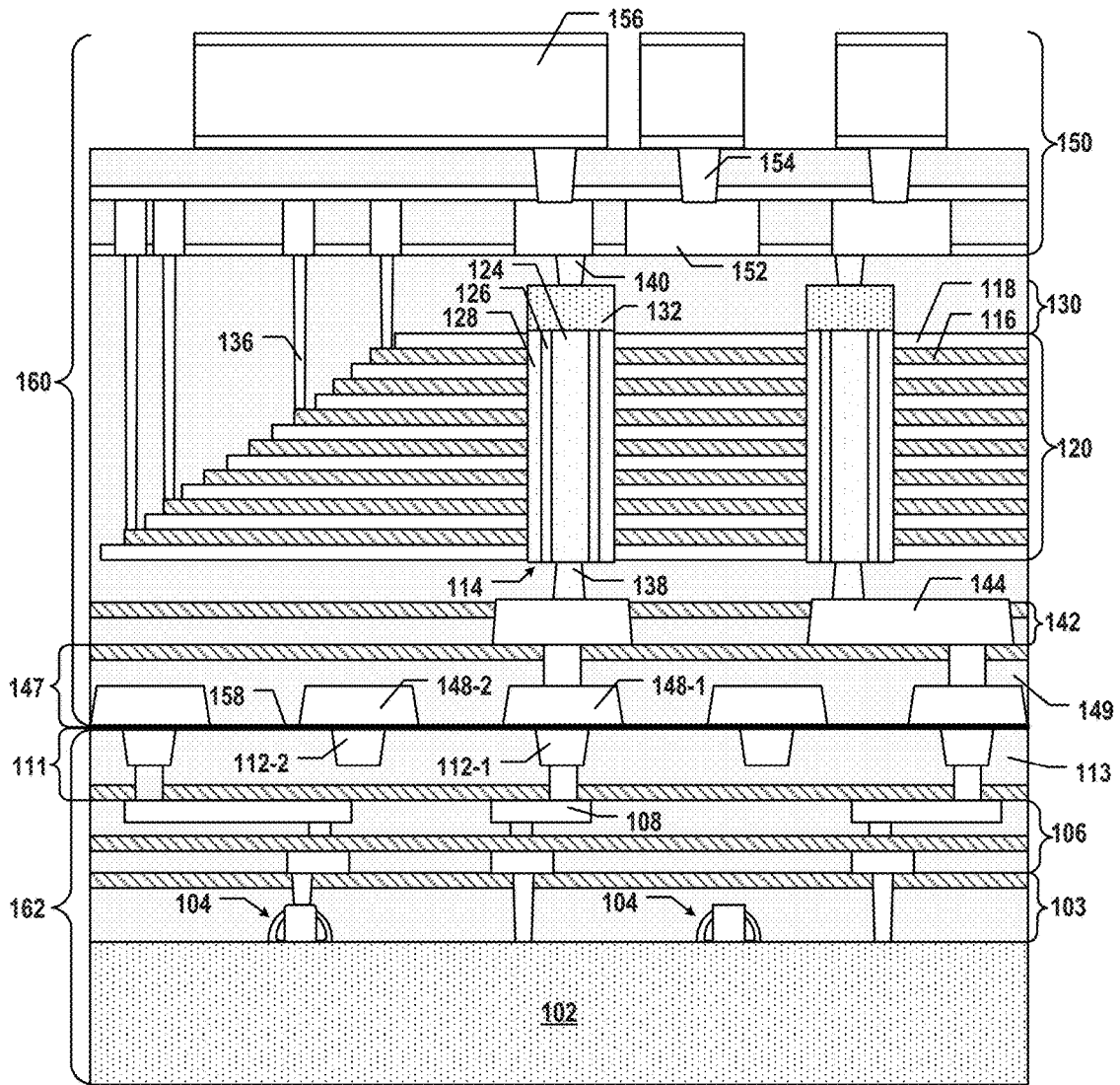

FIG. 1

200

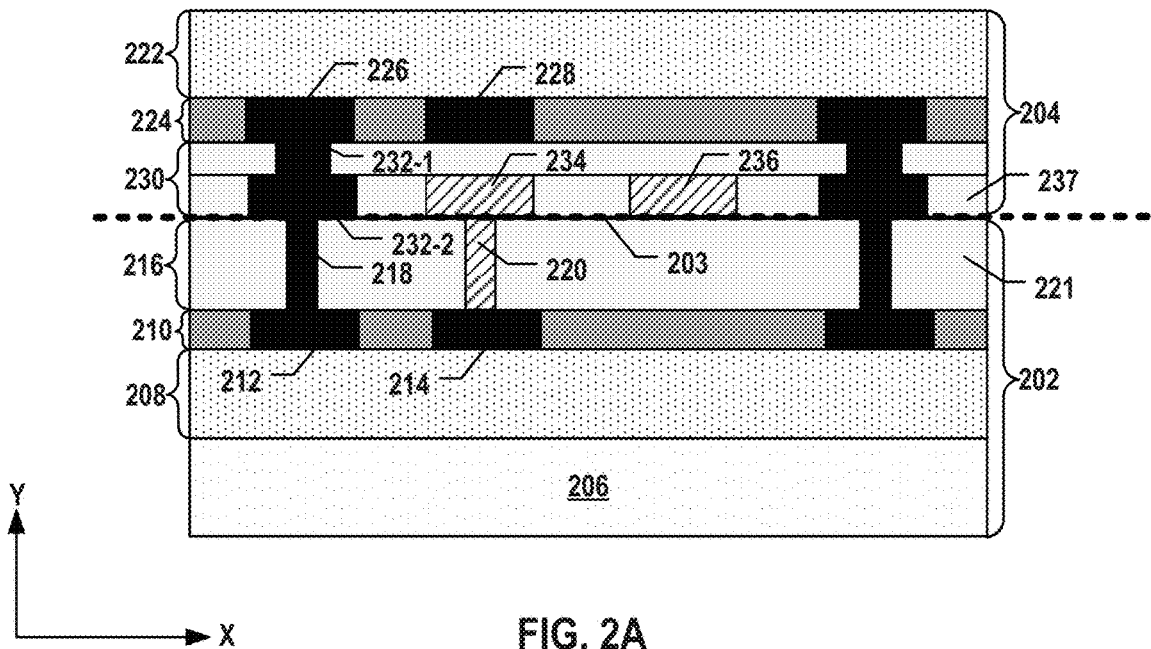

FIG. 2A

201

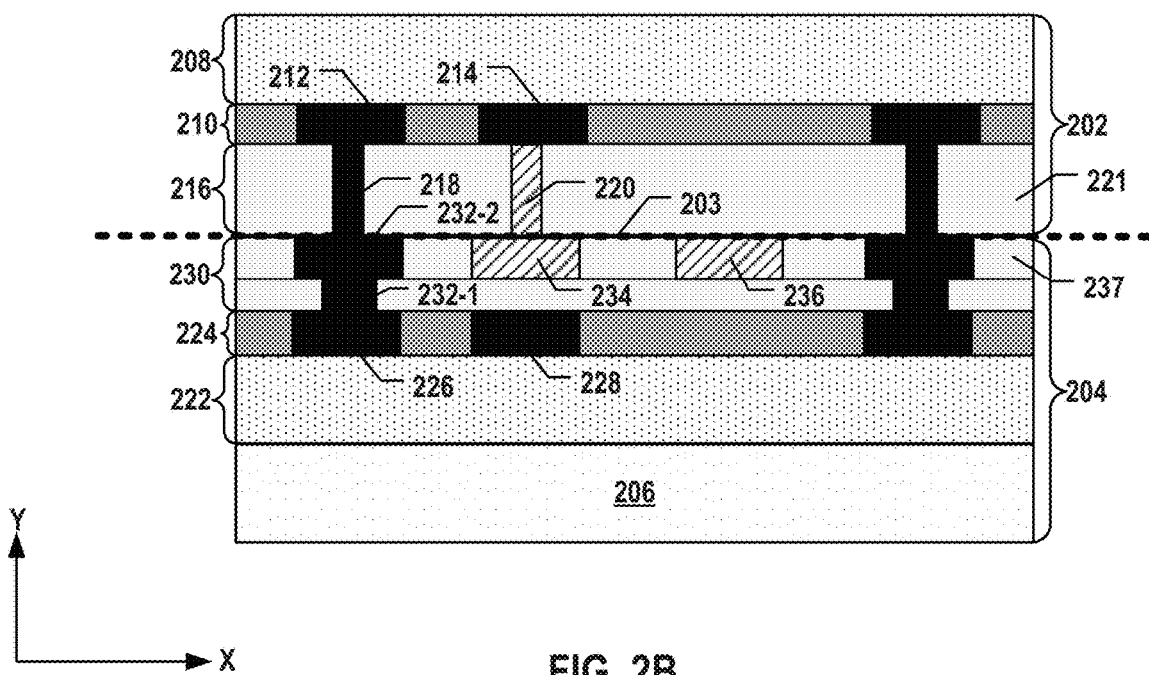

FIG. 2B

300

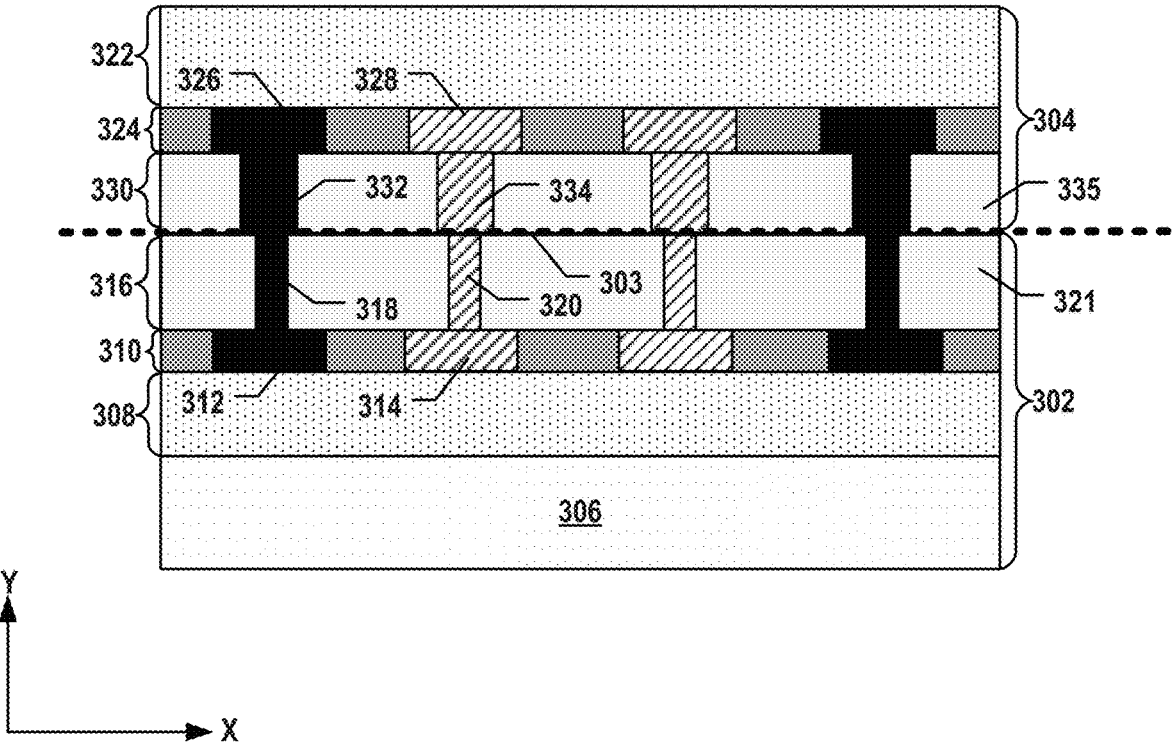

FIG. 3

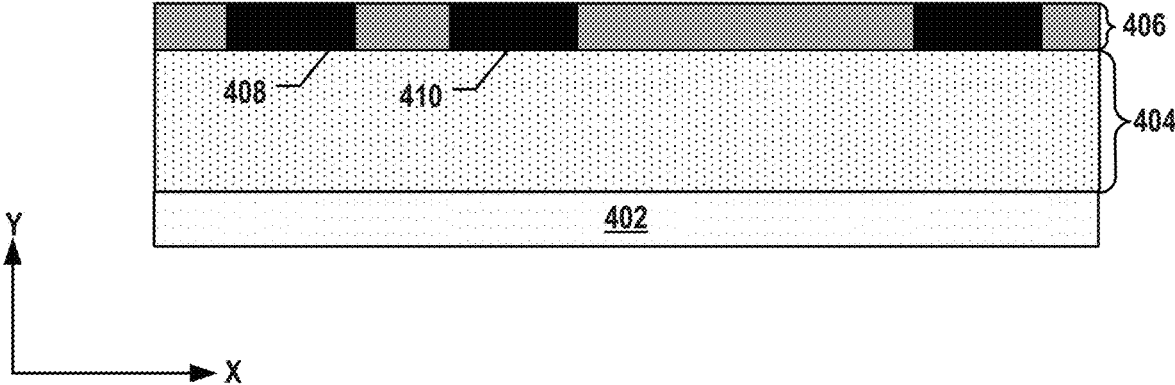

FIG. 4A

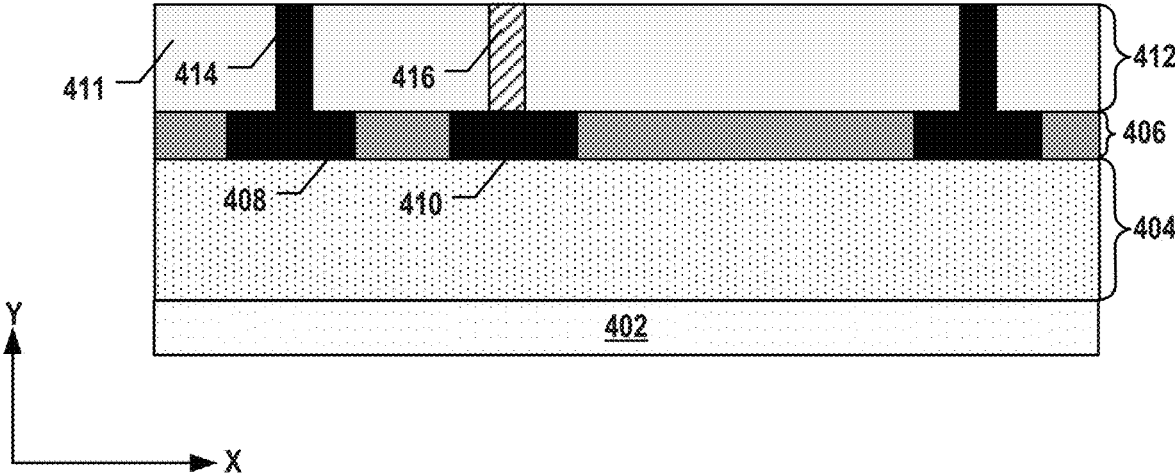
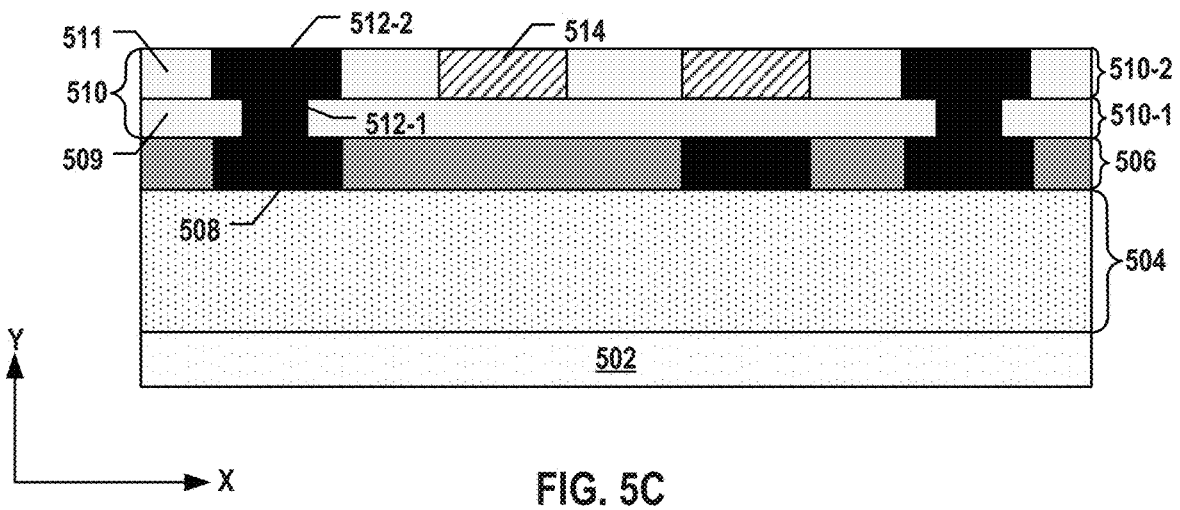
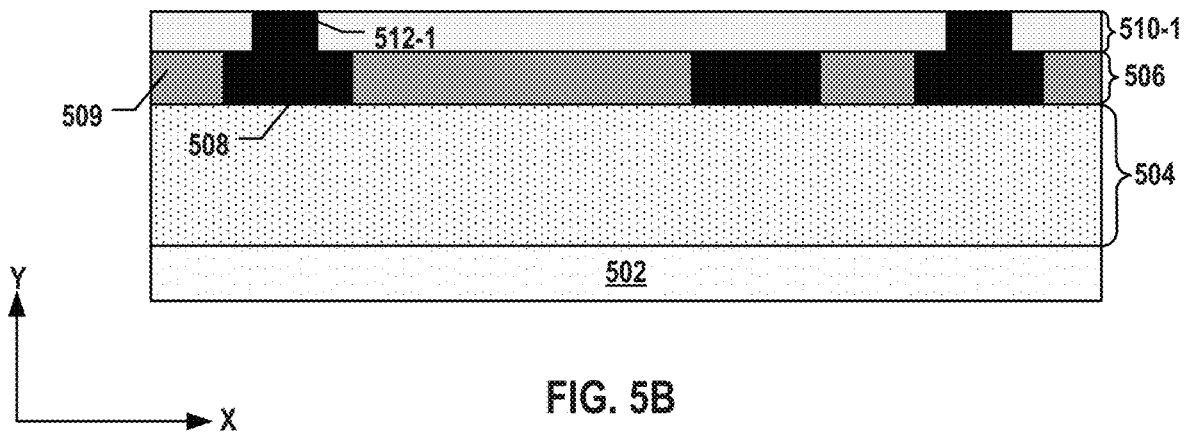
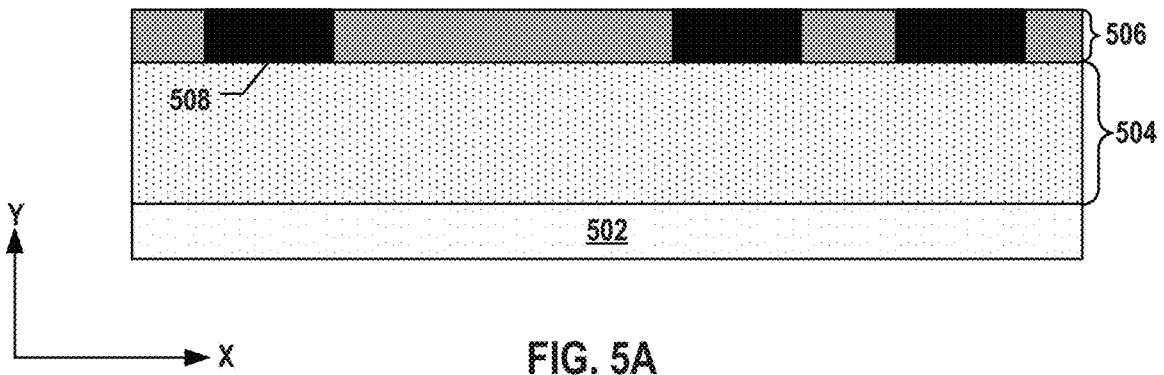

FIG. 4B



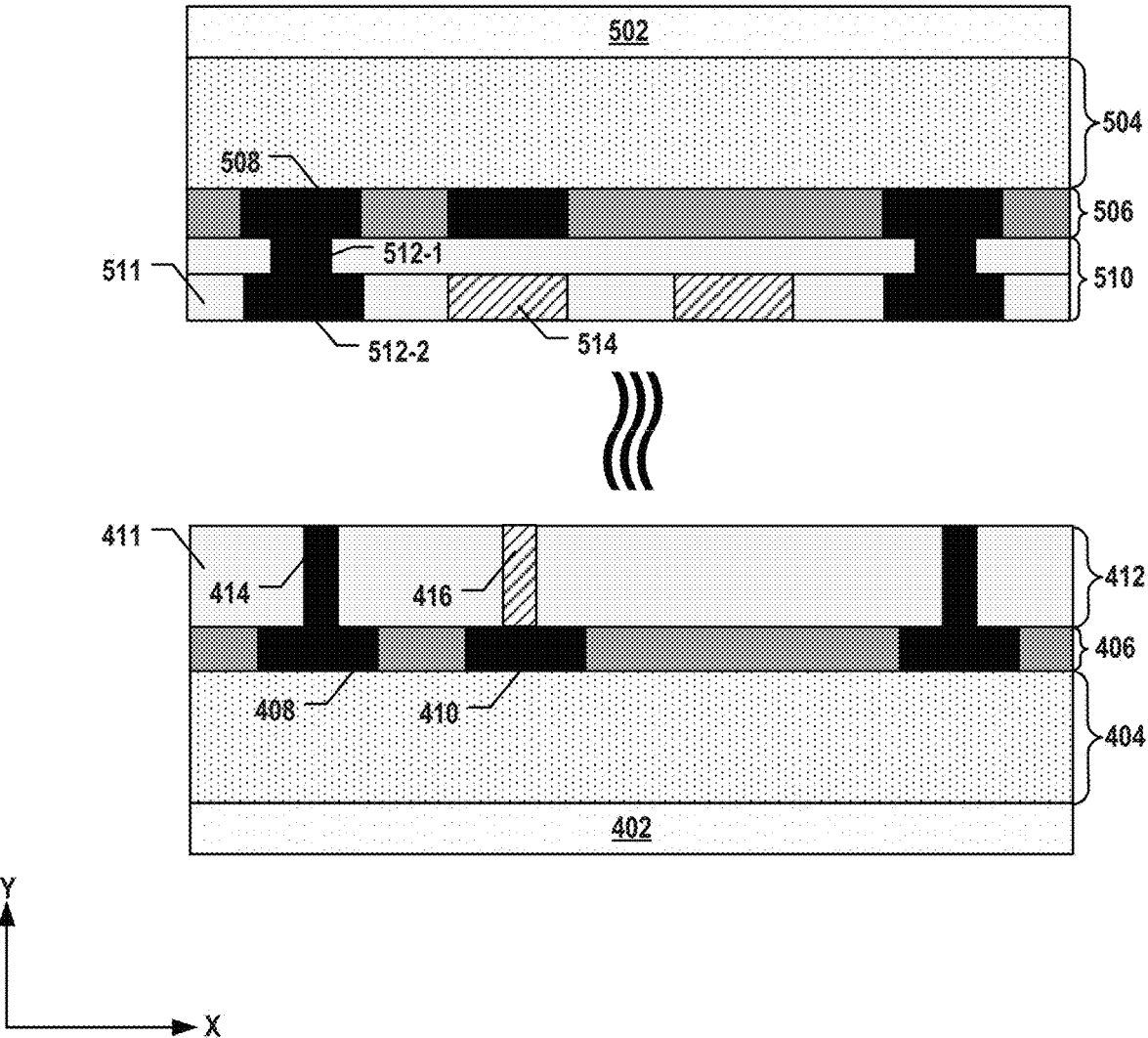

FIG. 6

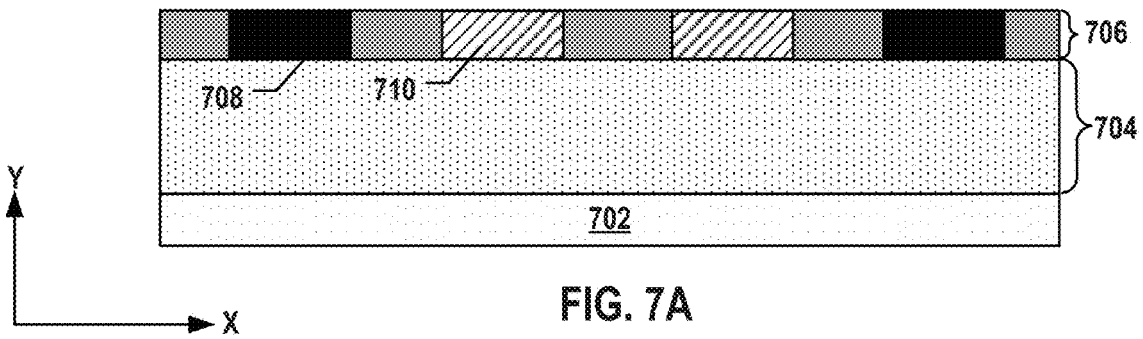

FIG. 7A

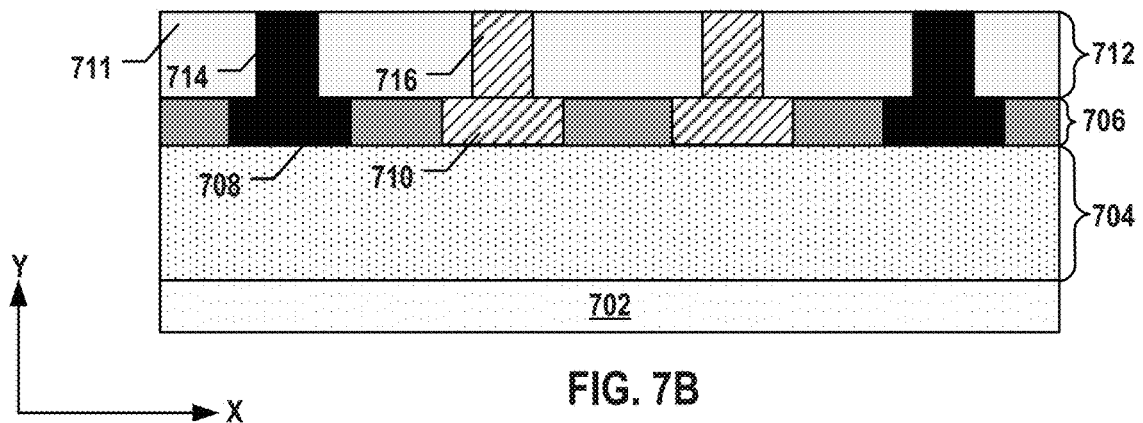

FIG. 7B

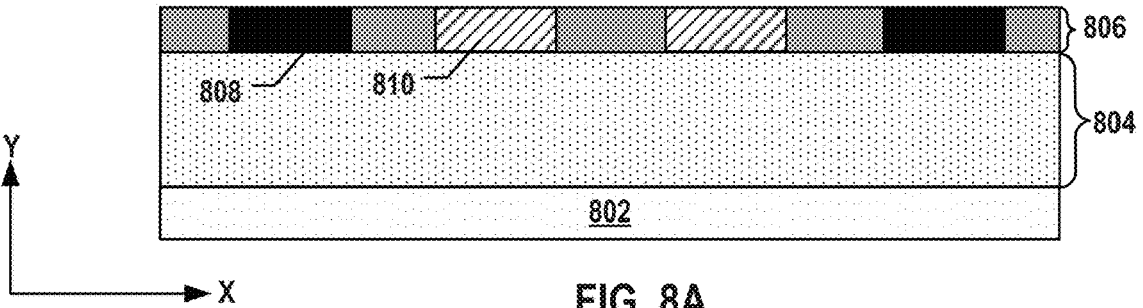

FIG. 8A

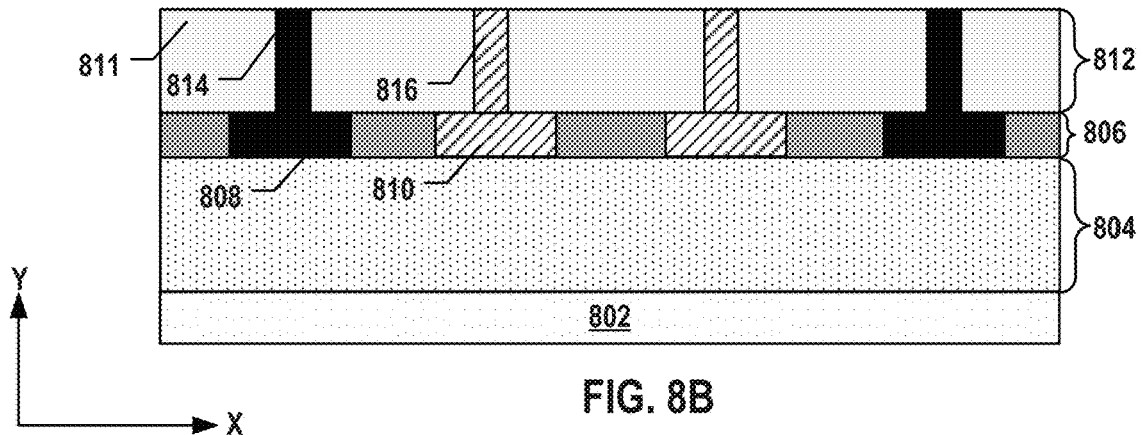

FIG. 8B



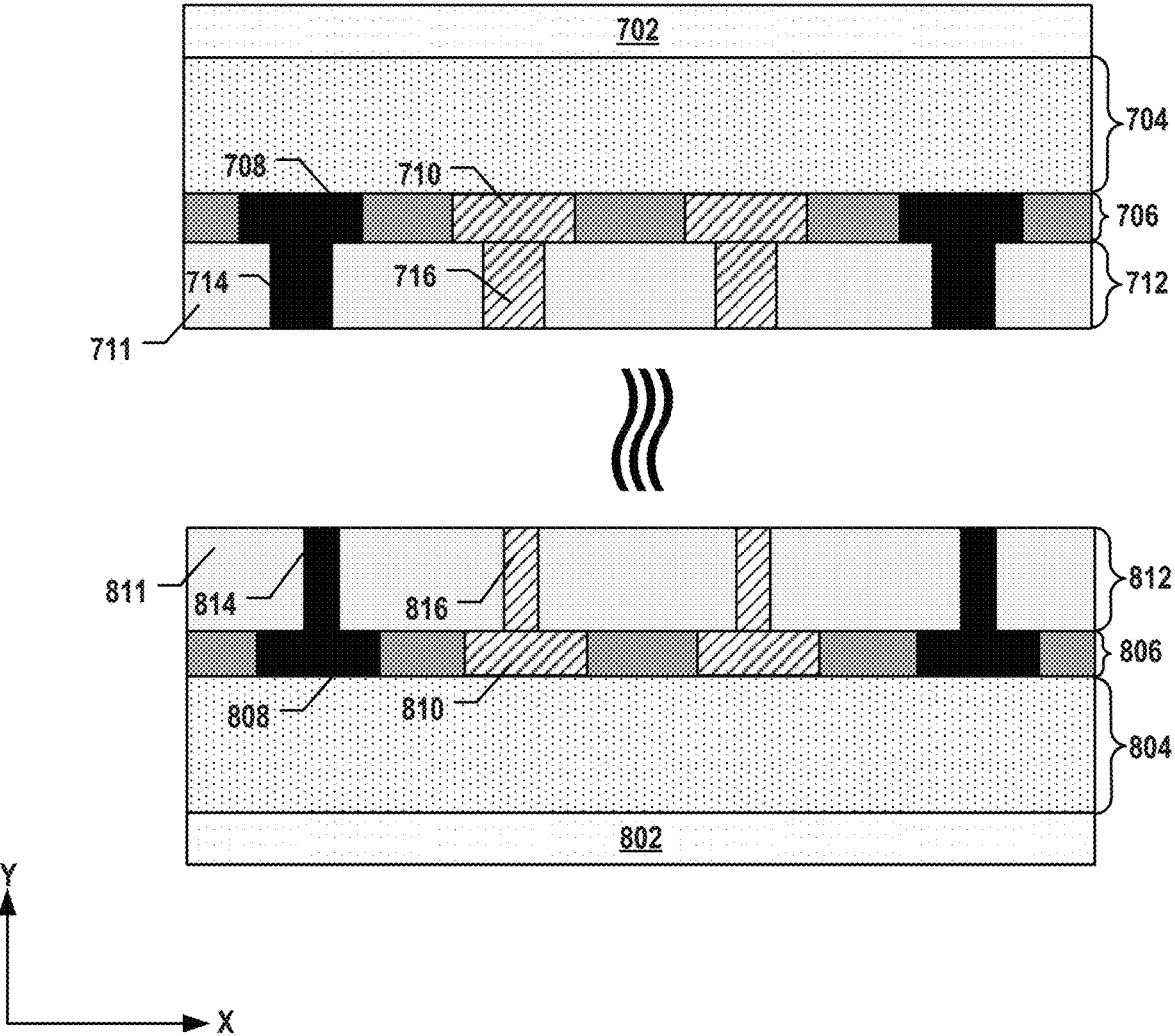
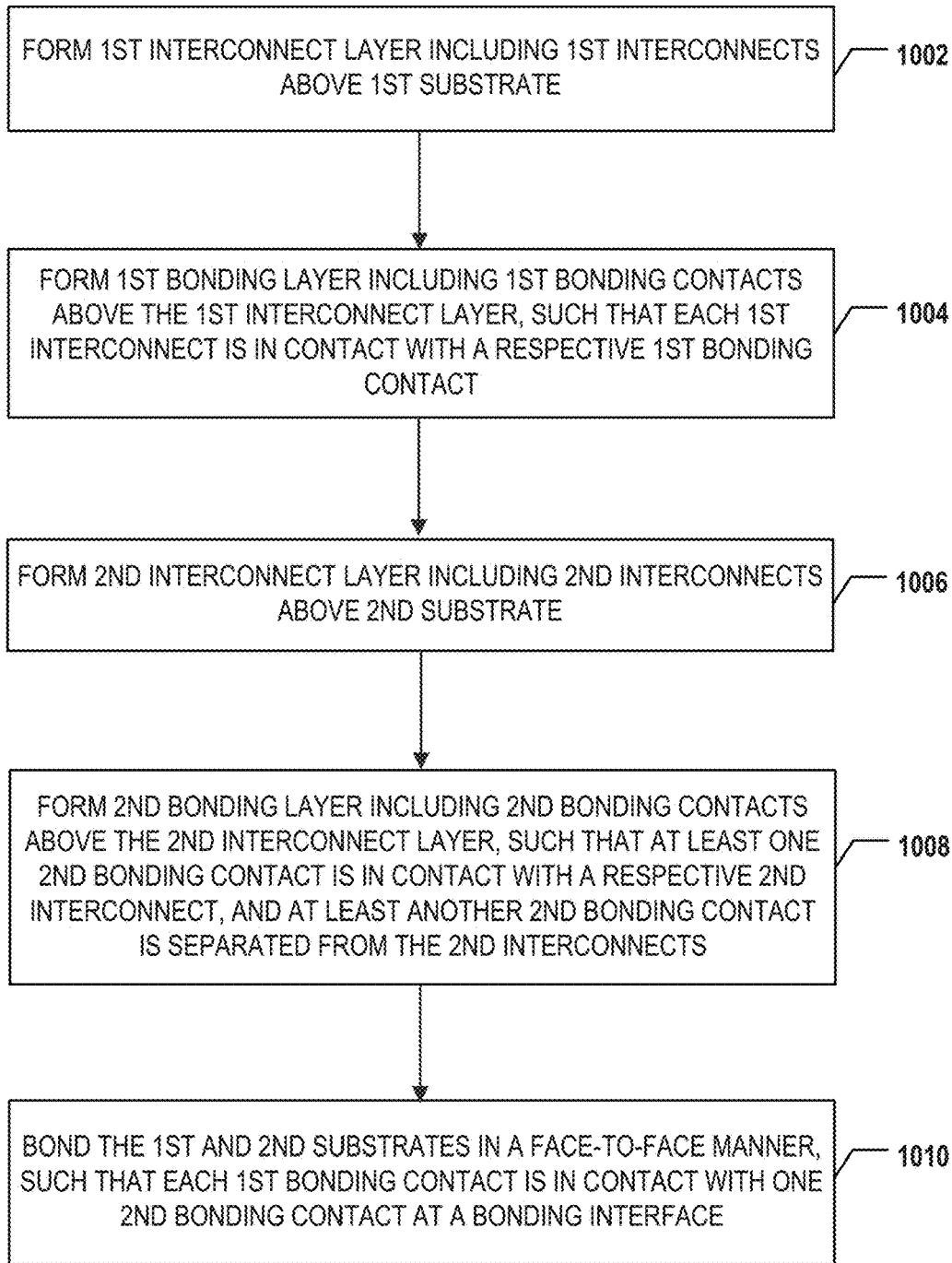

FIG. 9

**1000**



**FIG. 10**

**1100**

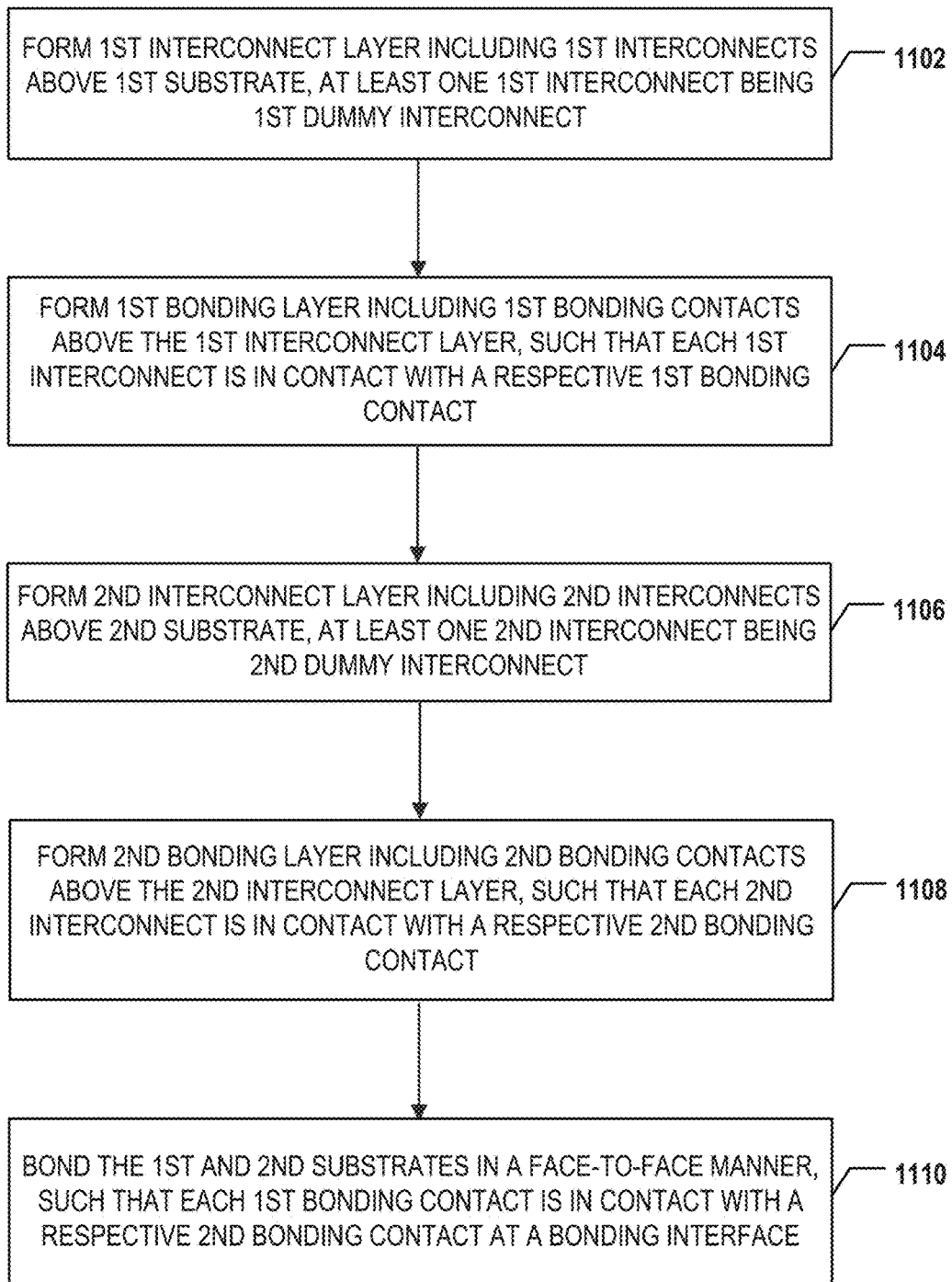

**FIG. 11**

## HYBRID BONDING USING DUMMY BONDING CONTACTS AND DUMMY INTERCONNECTS

### CROSS REFERENCE TO RELATED APPLICATION

[0001] This application is continuation of International Application No. PCT/CN2019/073909, filed on Jan. 30, 2019, entitled “HYBRID BONDING USING DUMMY BONDING CONTACTS AND DUMMY INTERCONNECTS,” which is hereby incorporated by reference in its entirety. This application is also related to co-pending U.S. application Ser. No. \_\_\_\_\_, Attorney Docketing No.: 10018-01-0033-US, filed on even date, entitled “HYBRID BONDING USING DUMMY BONDING CONTACTS,” which is hereby incorporated by reference in its entirety.

### BACKGROUND

[0002] Embodiments of the present disclosure relate to bonded semiconductor structures and fabrication methods thereof.

[0003] Planar semiconductor devices, such as memory cells, are scaled to smaller sizes by improving process technology, circuit design, programming algorithm, and fabrication process. However, as feature sizes of the semiconductor devices approach a lower limit, planar process and fabrication techniques become challenging and costly. A three-dimensional (3D) device architecture can address the density limitation in some planar semiconductor devices, for example, Flash memory devices.

[0004] A 3D semiconductor device can be formed by stacking semiconductor wafers or dies and interconnecting them vertically using, for instance, through-silicon vias (TSVs) or copper-to-copper (Cu—Cu) connections, so that the resulting structure acts as a single device to achieve performance improvements at reduced power and smaller footprint than conventional planar processes. Among the various techniques for stacking semiconductor substrates, hybrid bonding is recognized as one of the promising techniques because of its capability of forming high-density interconnects.

### SUMMARY

[0005] Embodiments of semiconductor devices, bonded structures, and fabrication methods thereof are disclosed herein.

[0006] In one example, a semiconductor device includes a first semiconductor structure and a second semiconductor structure. The first semiconductor structure includes a first interconnect layer including a plurality of first interconnects. At least one of the first interconnects is at least one first dummy interconnect. The first semiconductor structure further includes a first bonding layer including a plurality of first bonding contacts. Each of the first interconnects is in contact with a respective one of the first bonding contacts. The second semiconductor structure includes a second interconnect layer including a plurality of second interconnects. At least one of the second interconnects is at least one second dummy interconnect. The second semiconductor structure further includes a second bonding layer including a plurality of second bonding contacts. Each of the second interconnects is in contact with a respective one of the second bonding contacts. The semiconductor device further

includes a bonding interface between the first bonding layer and the second bonding layer. Each of the first bonding contacts is in contact with a respective one of the second bonding contacts at the bonding interface.

[0007] In another example, a bonded structure includes a bonding interface, a pair of functional bonding contacts, and a pair of dummy bonding contacts. The pair of functional bonding contacts are in contact with one another at the bonding interface. The pair of bonding contacts are in contact with a pair of functional interconnects on opposite sides of the bonding interface, respectively. The pair of dummy bonding contacts are in contact with one another at the bonding interface. The pair of dummy bonding contacts are in contact with a pair of dummy interconnects on the opposite sides of the bonding interface, respectively.

[0008] In still another example, a method for forming a semiconductor device is disclosed. A first interconnect layer including a plurality of first interconnects is formed above a first substrate. At least one of the first interconnects is at least one first dummy interconnect. A first bonding layer including a plurality of first bonding contacts is formed above the first interconnect layer, such that each of the first interconnects is in contact with a respective one of the first bonding contacts. A second interconnect layer including a plurality of second interconnects is formed above a second substrate. At least one of the second interconnects is at least one second dummy interconnect. A second bonding layer including a plurality of second bonding contacts is formed above the second interconnect layer, such that each of the second interconnects is in contact with a respective one of the second bonding contacts. The first substrate and the second substrate are bonded in a face-to-face manner, such that each of the first bonding contacts is in contact with a respective one of the second bonding contacts at a bonding interface.

### BRIEF DESCRIPTION OF THE DRAWINGS

[0009] The accompanying drawings, which are incorporated herein and form a part of the specification, illustrate embodiments of the present disclosure and, together with the description, further serve to explain the principles of the present disclosure and to enable a person skilled in the pertinent art to make and use the present disclosure.

[0010] FIG. 1 illustrates a cross-section of an exemplary bonded semiconductor device, according to some embodiments of the present disclosure.

[0011] FIGS. 2A and 2B illustrate cross-sections of various exemplary bonded semiconductor devices including dummy bonding contacts, according to various embodiments of the present disclosure.

[0012] FIG. 3 illustrates a cross-section of an exemplary bonded semiconductor device including dummy bonding contacts and dummy interconnects, according to some embodiments of the present disclosure.

[0013] FIGS. 4A and 4B illustrate an exemplary fabrication process for forming a first semiconductor structure including dummy bonding contacts, according to some embodiments of the present disclosure.

[0014] FIGS. 5A-5C illustrate an exemplary fabrication process for forming a second semiconductor structure including dummy bonding contacts, according to some embodiments of the present disclosure.

[0015] FIG. 6 illustrates an exemplary fabrication process for bonding a first semiconductor structure and a second semiconductor structure, according to some embodiments of the present disclosure.

[0016] FIGS. 7A and 7B illustrate an exemplary fabrication process for forming a first semiconductor structure including dummy bonding contacts and dummy interconnects, according to some embodiments of the present disclosure.

[0017] FIGS. 8A and 8B illustrate an exemplary fabrication process for forming a second semiconductor structure including dummy bonding contacts and dummy interconnects, according to some embodiments of the present disclosure.

[0018] FIG. 9 illustrates another exemplary fabrication process for bonding a first semiconductor structure and a second semiconductor structure, according to some embodiments of the present disclosure.

[0019] FIG. 10 is a flowchart of a method for forming an exemplary bonded semiconductor device including dummy bonding contacts, according to some embodiments of the present disclosure.

[0020] FIG. 11 is a flowchart of a method for forming an exemplary bonded semiconductor device including dummy bonding contacts and dummy interconnects, according to some embodiments of the present disclosure.

[0021] Embodiments of the present disclosure will be described with reference to the accompanying drawings.

#### DETAILED DESCRIPTION

[0022] Although specific configurations and arrangements are discussed, it should be understood that this is done for illustrative purposes only. A person skilled in the pertinent art will recognize that other configurations and arrangements can be used without departing from the spirit and scope of the present disclosure. It will be apparent to a person skilled in the pertinent art that the present disclosure can also be employed in a variety of other applications.

[0023] It is noted that references in the specification to “one embodiment,” “an embodiment,” “an example embodiment,” “some embodiments,” etc., indicate that the embodiment described may include a particular feature, structure, or characteristic, but every embodiment may not necessarily include the particular feature, structure, or characteristic. Moreover, such phrases do not necessarily refer to the same embodiment. Further, when a particular feature, structure or characteristic is described in connection with an embodiment, it would be within the knowledge of a person skilled in the pertinent art to effect such feature, structure or characteristic in connection with other embodiments whether or not explicitly described.

[0024] In general, terminology may be understood at least in part from usage in context. For example, the term “one or more” as used herein, depending at least in part upon context, may be used to describe any feature, structure, or characteristic in a singular sense or may be used to describe combinations of features, structures or characteristics in a plural sense. Similarly, terms, such as “a,” “an,” or “the,” again, may be understood to convey a singular usage or to convey a plural usage, depending at least in part upon context. In addition, the term “based on” may be understood as not necessarily intended to convey an exclusive set of factors and may, instead, allow for existence of additional

factors not necessarily expressly described, again, depending at least in part on context.

[0025] It should be readily understood that the meaning of “on,” “above,” and “over” in the present disclosure should be interpreted in the broadest manner such that “on” not only means “directly on” something but also includes the meaning of “on” something with an intermediate feature or a layer therebetween, and that “above” or “over” not only means the meaning of “above” or “over” something but can also include the meaning it is “above” or “over” something with no intermediate feature or layer therebetween (i.e., directly on something).

[0026] Further, spatially relative terms, such as “beneath,” “below,” “lower,” “above,” “upper,” and the like, may be used herein for ease of description to describe one element or feature’s relationship to another element(s) or feature(s) as illustrated in the figures. The spatially relative terms are intended to encompass different orientations of the device in use or operation in addition to the orientation depicted in the figures. The apparatus may be otherwise oriented (rotated 90 degrees or at other orientations) and the spatially relative descriptors used herein may likewise be interpreted accordingly.

[0027] As used herein, the term “substrate” refers to a material onto which subsequent material layers are added. The substrate itself can be patterned. Materials added on top of the substrate can be patterned or can remain unpatterned. Furthermore, the substrate can include a wide array of semiconductor materials, such as silicon, germanium, gallium arsenide, indium phosphide, etc. Alternatively, the substrate can be made from an electrically non-conductive material, such as a glass, a plastic, or a sapphire wafer.

[0028] As used herein, the term “layer” refers to a material portion including a region with a thickness. A layer can extend over the entirety of an underlying or overlying structure or may have an extent less than the extent of an underlying or overlying structure. Further, a layer can be a region of a homogeneous or inhomogeneous continuous structure that has a thickness less than the thickness of the continuous structure. For example, a layer can be located between any pair of horizontal planes between, or at, a top surface and a bottom surface of the continuous structure. A layer can extend horizontally, vertically, and/or along a tapered surface. A substrate can be a layer, can include one or more layers therein, and/or can have one or more layer thereupon, thereabove, and/or therebelow. A layer can include multiple layers. For example, an interconnect layer can include one or more conductor and contact layers (in which interconnect lines and/or via contacts are formed) and one or more dielectric layers.

[0029] As used herein, the term “nominal/nominally” refers to a desired, or target, value of a characteristic or parameter for a component or a process operation, set during the design phase of a product or a process, together with a range of values above and/or below the desired value. The range of values can be due to slight variations in manufacturing processes or tolerances. As used herein, the term “about” indicates the value of a given quantity that can vary based on a particular technology node associated with the subject semiconductor device. Based on the particular technology node, the term “about” can indicate a value of a given quantity that varies within, for example, 10-30% of the value (e.g.,  $\pm 10\%$ ,  $\pm 20\%$ , or  $\pm 30\%$  of the value).

**[0030]** As used herein, the term “3D memory device” refers to a semiconductor device with vertically oriented strings of memory cell transistors (referred to herein as “memory strings,” such as NAND memory strings) on a laterally-oriented substrate so that the memory strings extend in the vertical direction with respect to the substrate. As used herein, the term “vertical/vertically” means nominally perpendicular to the lateral surface of a substrate.

**[0031]** In a high density, low feature size (e.g., below 0.5  $\mu\text{m}$ ) hybrid bonding process, in order to increase the bonding yield, the bonding contacts on opposite sides of the bonding interface are often made by two dual damascene processes each involving two patterning processes (e.g., two photolithography and development processes). To reduce the high cost of using four patterning processes, fabrication processes involving only three or even two patterning processes have been proposed to make the bonding contacts. However, known processes cannot form dummy bonding contacts at the bonding interface to achieve desired uniformity of metal and dielectric distribution at the bonding interface, thereby decreasing the bonding yield and strength. For example, the variation of metal local density can cause the nonuniformity of erosion control and dishing control during the subsequent chemical mechanical polishing (CMP) process. Also, the lack of dummy bonding contacts can cause a large number of metal-dielectric bonding and dielectric-dielectric bonding regions, which have lower bonding strengths than metal-metal bonding regions.

**[0032]** Various embodiments in accordance with the present disclosure provide hybrid bonding using dummy bonding contacts for improving bonding yield and strength. The dummy bonding contacts and functional bonding contacts on at least one side of the bonding interface can be made in a single patterning process, thereby reducing the process cost. In some embodiments, the local density of the bonding contacts can be controlled by adding the dummy bonding contacts based on the design of the interconnects in the lower layer to increase the bonding yield and strength. In some embodiments, the dummy bonding contacts and functional bonding contacts on each side of the bonding interface are made in a single patterning process, thereby further reducing the cost of the hybrid bonding process. Dummy interconnects can be added into the interconnect layer to enable adding additional dummy bonding contacts in the upper layer in a single patterning process without affecting the electrical connections in the bonded device.

**[0033]** FIG. 1 illustrates a cross-section of an exemplary bonded semiconductor device 100, according to some embodiments of the present disclosure. For ease of description, bonded semiconductor device 100 will be described as a non-monolithic 3D memory device. However, it is understood that bonded semiconductor device 100 is not limited to a 3D memory device and can include any suitable bonded semiconductor devices that can use dummy bonding contacts to improve bonding interface properties as described below in detail. It is understood that bonded semiconductor devices that include dummy bonding contacts at its bonding interface as disclosed herein are not limited to the examples shown in FIG. 1 and can include any other suitable semiconductor devices, such as logic devices, volatile memory devices (e.g., dynamic random-access memory (DRAM) and static random-access memory (SRAM)), and non-volatile memory devices (e.g., Flash memory), in a 2D, 2.5D, or 3D architecture.

**[0034]** Bonded semiconductor device 100 represents an example of a non-monolithic 3D memory device. The term “non-monolithic” means that the components of bonded semiconductor device 100 (e.g., peripheral devices and memory array devices) can be formed separately on different substrates and then bonded to form a bonded semiconductor device. Bonded semiconductor device 100 can include a substrate 102, which can include silicon (e.g., single crystalline silicon), silicon germanium (SiGe), gallium arsenide (GaAs), germanium (Ge), silicon on insulator (SOI), or any other suitable materials.

**[0035]** It is noted that x and y axes are included in FIG. 1 to further illustrate the spatial relationship of the components in bonded semiconductor device 100 having substrate 102. Substrate 102 includes two lateral surfaces (e.g., a top surface and a bottom surface) extending laterally in the x-direction (i.e., the lateral direction). As used herein, whether one component (e.g., a layer or a device) is “on,” “above,” or “below” another component (e.g., a layer or a device) of a semiconductor device (e.g., bonded semiconductor device 100) is determined relative to the substrate of the semiconductor device (e.g., substrate 102) in the y-direction (i.e., the vertical direction) when the substrate is positioned in the lowest plane of the semiconductor device in the y-direction. The same notion for describing spatial relationship is applied throughout the present disclosure.

**[0036]** Bonded semiconductor device 100 can include two semiconductor structures, i.e., a memory array device chip 160 and a peripheral device chip 162 bonded in a face-to-face manner at a bonding interface 158. In some embodiments, bonding interface 158 is disposed between memory array device chip 160 and peripheral device chip 162 as a result of hybrid bonding (also known as “metal/dielectric hybrid bonding”), which is a direct bonding technology (e.g., forming bonding between surfaces without using intermediate layers, such as solder or adhesives) and can obtain metal-metal bonding and dielectric-dielectric bonding simultaneously. In some embodiments, bonding interface 158 is the place at which memory array device chip 160 and peripheral device chip 162 are met and bonded. In practice, bonding interface 158 can be a layer with a certain thickness that includes the bottom surface of memory array device chip 160 and the bottom surface of peripheral device chip 162. It is understood that although memory array device chip 160 is disposed above peripheral device chip 162 in FIG. 1, their relative positions can be reversed in some embodiments. For example, memory array device chip 160 can be disposed below peripheral device chip 162 in another bonded semiconductor device.

**[0037]** Peripheral device chip 162 can include a peripheral device layer 103 on substrate 102. Peripheral device layer 103 can include a peripheral device (e.g., a plurality of transistors 104) formed on substrate 102. Transistors 104 can be formed “on” substrate 102, where the entirety or part of each transistor 104 is formed in substrate 102 (e.g., below the top surface of substrate 102) and/or directly on substrate 102. Isolation regions (e.g., shallow trench isolations (STIs), not shown) and doped regions (e.g., source regions and drain regions of transistors 104, not shown) can be formed in substrate 102.

**[0038]** In some embodiments, the peripheral device of peripheral device layer 103 can include any suitable digital, analog, and/or mixed-signal peripheral circuits used for facilitating the operation of bonded semiconductor device

**100.** For example, the peripheral device of peripheral device layer **103** can include one or more of a page buffer, a decoder (e.g., a row decoder and a column decoder), a sense amplifier, a driver, a charge pump, a current or voltage reference, or any active or passive components of the circuits (e.g., transistors, diodes, resistors, or capacitors). In some embodiments, the peripheral device of peripheral device layer **103** is formed on substrate **102** using complementary metal-oxide-semiconductor (CMOS) technology (also known as a “CMOS chip”).

**[0039]** Peripheral device chip **162** can include an interconnect layer **106** (referred to herein as a “peripheral interconnect layer”) above peripheral device layer **103** to transfer electrical signals to and from peripheral device layer **103**. Peripheral interconnect layer **106** can include a plurality of interconnects **108** (also referred to herein as “contacts”), including lateral interconnect lines and vertical interconnect access (via) contacts. As used herein, the term “interconnects” can broadly include any suitable types of interconnects, such as middle-end-of-line (MEOL) interconnects and back-end-of-line (BEOL) interconnects. As described below in detail, interconnects **108** in peripheral interconnect layer **106** can include functional interconnects that are electrically connected to the peripheral device and optionally, further include dummy interconnects that are not electrically connected to any peripheral device in peripheral device layer **103**. Peripheral interconnect layer **106** can further include one or more interlayer dielectric (ILD) layers (also known as “intermetal dielectric (IMD) layers”) in which the interconnect lines and via contacts can form. That is, peripheral interconnect layer **106** can include interconnects **108** in multiple ILD layers. Interconnects **108** in peripheral interconnect layer **106** can include conductive materials including, but not limited to, tungsten (W), cobalt (Co), copper (Cu), aluminum (Al), silicides, or any combination thereof. The ILD layers in peripheral interconnect layer **106** can include dielectric materials including, but not limited to, silicon oxide, silicon nitride, silicon oxynitride, low dielectric constant (low-k) dielectrics, or any combination thereof.

**[0040]** As shown in FIG. 1, peripheral device chip **162** can further include a bonding layer **111** at bonding interface **158** and above peripheral interconnect layer **106** and peripheral device layer **103**. Bonding layer **111** can include a plurality of bonding contacts **112** and a dielectric **113** electrically isolating bonding contacts **112**. Bonding contacts **112** can include functional bonding contacts **112-1**, each of which is part of an electrical connection between peripheral device chip **162** and memory array device chip **160**. Bonding contacts **112** can also include dummy bonding contacts **112-2**, each of which is not part of any electrical connection between peripheral device chip **162** and memory array device chip **160**. As described below in detail, dummy bonding contacts **112-2** can be used for increasing the local density of bonding contacts **112** at bonding interface **158** to increase bonding yield and strength. Bonding contacts **112** can include conductive materials including, but not limited to, W, Co, Cu, Al, silicides, or any combination thereof. The remaining area of bonding layer **111** can be formed with dielectric **113** including, but not limited to, silicon oxide, silicon nitride, silicon oxynitride, low-k dielectrics, or any combination thereof. Bonding contacts **112** and dielectric **113** in bonding layer **111** can be used for hybrid bonding as described below in detail.

**[0041]** In some embodiments, memory array device chip **160** is a NAND Flash memory device in which memory cells are provided in the form of an array of NAND memory strings **114** each extending vertically above peripheral device layer **103**. Memory array device layer **120** can include NAND memory strings **114** that extend vertically through a plurality of pairs each including a conductor layer **116** and a dielectric layer **118** (referred to herein as “conductor/dielectric layer pairs”). The stacked conductor/dielectric layer pairs are also referred to herein as a “memory stack.” Conductor layers **116** and dielectric layers **118** in the memory can stack alternately in the vertical direction.

**[0042]** As shown in FIG. 1, each NAND memory string **114** can include a semiconductor channel **124** and a dielectric layer (also known as a “memory film”). In some embodiments, semiconductor channel **124** includes silicon, such as amorphous silicon, polysilicon, or single crystalline silicon. In some embodiments, the memory film is a composite layer including a tunneling layer **126**, a storage layer **128** (also known as a “charge trap/storage layer”), and a blocking layer (not shown). Each NAND memory string **114** can have a cylinder shape (e.g., a pillar shape). Semiconductor channel **124**, tunneling layer **126**, storage layer **128**, and the blocking layer are arranged radially from the center toward the outer surface of the pillar in this order, according to some embodiments. Tunneling layer **126** can include silicon oxide, silicon oxynitride, or any combination thereof. Storage layer **128** can include silicon nitride, silicon oxynitride, silicon, or any combination thereof. The blocking layer can include silicon oxide, silicon oxynitride, high dielectric constant (high-k) dielectrics, or any combination thereof.

**[0043]** In some embodiments, NAND memory strings **114** further include a plurality of control gates (each being part of a word line). Each conductor layer **116** in the memory stack can act as a control gate for memory cell of each NAND memory string **114**. Each NAND memory string **114** can include a source select gate at its upper end and a drain select gate at its lower end. As used herein, the “upper end” of a component (e.g., NAND memory string **114**) is the end farther away from substrate **102** in the y-direction, and the “lower end” of the component (e.g., NAND memory string **114**) is the end closer to substrate **102** in the y-direction.

**[0044]** In some embodiments, memory array device chip **160** further includes a semiconductor layer **130** disposed above and in contact with NAND memory strings **114**. Memory array device layer **120** can be disposed below semiconductor layer **130**. In some embodiments, semiconductor layer **130** includes a plurality of semiconductor plugs **132** electrically separated by isolation regions. In some embodiments, each semiconductor plug **132** is disposed at the upper end of corresponding NAND memory string **114** and functions as the drain of corresponding NAND memory string **114** and thus, can be considered as part of corresponding NAND memory string **114**. Semiconductor plug **132** can include a single crystalline silicon. Semiconductor plug **132** can be un-doped, partially doped (in the thickness direction and/or the width direction), or fully doped by p-type or n-type dopants.

**[0045]** In some embodiments, memory array device chip **160** includes local interconnects that are formed in one or more ILD layers and in contact with components in memory array device layer **120**, such as the word lines (e.g., conductor layers **116**) and NAND memory strings **114**. The local interconnects can include word line via contacts **136**,

source line via contacts **138**, and bit line via contacts **140**. Each local interconnect can include conductive materials including, but not limited to, W, Co, Cu, Al, silicides, or any combination thereof. Word line via contacts **136** can extend vertically through one or more ILD layers. Each word line via contact **136** can be in contact with corresponding conductor layer **116** to individually address a corresponding word line of bonded semiconductor device **100**. Each source line via contact **138** can be in contact with the source of corresponding NAND memory string **114**. Bit line via contacts **140** can extend vertically through one or more ILD layers. Each bit line via contact **140** can electrically connect to corresponding semiconductor plug **132** (e.g., the drain) of NAND memory string **114** to individually address corresponding NAND memory string **114**.

[0046] Similar to peripheral device chip **162**, memory array device chip **160** can also include interconnect layers for transferring electrical signals to and from NAND memory strings **114**. As shown in FIG. 1, memory array device chip **160** can include an interconnect layer **142** (referred to herein as an “array interconnect layer”) below memory array device layer **120**. Array interconnect layer **142** can include a plurality of interconnects **144**, including interconnect lines and via contacts in one or more ILD layers. As described below in detail, interconnects **144** in array interconnect layer **142** can include functional interconnects that are electrically connected to NAND memory string **114** and optionally, further include dummy interconnects that are not electrically connected to any NAND memory string **114** in memory array device layer **120**.

[0047] As shown in FIG. 1, memory array device chip **160** can further include a bonding layer **147** at bonding interface **158** and below array interconnect layer **142** and memory array device layer **120**. Bonding layer **147** can include a plurality of bonding contacts **148** and a dielectric **149** electrically isolating bonding contacts **148**. Bonding contacts **148** can include functional bonding contacts **148-1**, each of which is part of an electrical connection between peripheral device chip **162** and memory array device chip **160**. Bonding contacts **148** can also include dummy bonding contacts **148-2**, each of which is not part of any electrical connection between peripheral device chip **162** and memory array device chip **160**. As described below in detail, dummy bonding contacts **148-2** can be used for increasing the local density of bonding contacts **148** at bonding interface **158** to increase bonding yield and strength. Bonding contacts **148** can include conductive materials including, but not limited to, W, Co, Cu, Al, silicides, or any combination thereof. The remaining area of bonding layer **147** can be formed with dielectric **149** including, but not limited to, silicon oxide, silicon nitride, silicon oxynitride, low-k dielectrics, or any combination thereof. Bonding contacts **148** and dielectric **149** in bonding layer **147** can be used for hybrid bonding as described below in detail.

[0048] As shown in FIG. 1, another interconnect layer **150** (referred to herein as a “BEOL interconnect layer”) can be disposed above memory array device layer **120** and can include interconnects, such as interconnect lines **152** and via contacts **154** in one or more ILD layers. BEOL interconnect layer **150** can further include contact pads **156** and a redistribution layer (not shown) at the top portion of bonded semiconductor device **100** for wire bonding and/or bonding with an interposer. BEOL interconnect layer **150** and array interconnect layer **142** can be formed on opposite sides of

memory array device layer **120**. In some embodiments, interconnect lines **152**, via contacts **154**, and contact pads **156** in BEOL interconnect layer **150** can transfer electrical signals between bonded semiconductor device **100** and external circuits.

[0049] As shown in FIG. 1, bonding interface **158** can be formed between bonding layers **111** and **147**. Bonding contacts **112** are in contact with bonding contacts **148** at bonding interface **158**, and dielectric **113** is in contact with dielectric **149**, according to some embodiments. In some embodiments, a pair of functional bonding contacts **112-1** and **148-1** are in contact with one another at bonding interface **158**, and pair of functional bonding contacts **112-1** and **148-1** are in contact with a pair of interconnects **108** and **144** on opposite sides of bonding interface **158**, respectively. In some embodiments, a pair of dummy bonding contacts **112-2** and **148-2** are in contact with one another at bonding interface **158** as well. As dummy bonding contacts for improving metal density and uniformity at bonding interface **158** for hybrid bonding, dummy bonding contacts **112-2** and **148-2** in pair are separated from the functional interconnects on at least one side of bonding interface **158** (e.g., in peripheral interconnect layer **106** and/or array interconnect layer **142**) to avoid forming an electrical connection between memory array device chip **160** and peripheral device chip **162**. In some embodiments, peripheral interconnect layer **106** and array interconnect layer **142** include a pair of dummy interconnects that are not electrically connected to NAND memory strings **114** and transistors **104**, and pair of dummy bonding contacts **112-2** and **148-2** can be in contact with the pair of dummy interconnects on the opposite sides of bonding interface **158**, respectively, without forming an electrical connection between memory array device chip **160** and peripheral device chip **162**. In some embodiments, a pair of dielectrics **113** and **149** are in contact with one another at bonding interface **158** as well.

[0050] FIGS. 2A and 2B illustrate cross-sections of various exemplary bonded semiconductor devices including dummy bonding contacts, according to various embodiments of the present disclosure. FIG. 2A illustrates a bonded structure **200** including a first semiconductor structure **202** and a second semiconductor structure **204**, according to some embodiments. As shown in FIG. 2A, first semiconductor structure **202** is disposed below second semiconductor structure **204** in bonded structure **200** and includes a substrate **206**, according to some embodiments. First semiconductor structure **202** can also include a first device layer **208** above substrate **206**. In some embodiments, first semiconductor structure **202** is a peripheral device chip or a memory array device chip, and first device layer **208** includes a peripheral device or a NAND memory string, respectively, as described above in FIG. 1. Similarly, second semiconductor structure **204** can include a second device layer **222**. In some embodiments, second semiconductor structure **204** is a memory array device chip or a peripheral device chip, and second device layer **222** includes a NAND memory string or a peripheral device, respectively, as described above in FIG. 1. Bonded structure **200** can further include a bonding interface **203** between first and second semiconductor structures **202** and **204**. It is understood that bonded structure **200** can include any other suitable semiconductor devices, such as logic devices, volatile memory devices (e.g., dynamic random-access memory (DRAM))



and static random-access memory (SRAM)), and non-volatile memory devices (e.g., Flash memory), in a 2D, 2.5D, or 3D architecture.

[0051] First semiconductor structure 202 can also include a first interconnect layer 210 above first device layer 208. First interconnect layer 210 includes interconnects 212 and 214 in one or more ILD layers, according to some embodiments. Two types of interconnects 212 and 214 can be formed in first interconnect layer 210 depending on their functionalities. In some embodiments, each interconnect 212 is a functional MEOL or BEOL interconnect (e.g., interconnect line or via contact) that is electrically connected to both first device layer 208 of first semiconductor structure 202 and second device layer 222 of second semiconductor structure 204 to transfer electrical signals across bonding interface 203 and between first and second semiconductor structure 202 and 204. Interconnect 214 can be a functional MEOL or BEOL interconnect (e.g., interconnect line or via contact) that is electrically connected to first device layer 208 of first semiconductor structure 202, but not second device layer 222 of second semiconductor structure 204, to transfer electrical signals within first semiconductor structure 202. In some embodiments, interconnect 214 is a dummy interconnect that is not electrically connected to first device layer 208 of first semiconductor structure 202. Interconnects 212 and 214 in first interconnect layer 210 can include conductive materials including, but not limited to, W, Co, Cu, Al, silicides, or any combination thereof. The ILD layers in first interconnect layer 210 can include dielectric materials including, but not limited to, silicon oxide, silicon nitride, silicon oxynitride, low-k dielectrics, or any combination thereof.

[0052] First semiconductor structure 202 can further include a first bonding layer 216 above first interconnect layer 210. First bonding layer 216 includes bonding contacts 218 and 220 in one ILD layer, according to some embodiments. To reduce the fabrication cost, first bonding layer 216 can be formed by a single patterning process (e.g., involving only one photolithography and development process) in a single ILD layer. As a result, in some embodiments, each bonding contact 218 or 220 has a nominally same critical dimension (e.g., the diameter of a via contact). In some embodiments, each bonding contact 218 or 220 is a single damascene contact, as opposed to a dual damascene contact. Two types of bonding contacts 218 and 220 can be formed in first bonding layer 216 depending on whether it is part of an electrical connection between first and second semiconductor structures 202 and 204. In some embodiments, each bonding contact 218 is a functional bonding contact that is part of an electrical connection across bonding interface 203 and between first and second semiconductor structures 202 and 204. In some embodiments, bonding contact 220 is a dummy bonding contact that is not part of an electrical connection across bonding interface 203 and between first and second semiconductor structures 202 and 204. Bonding contacts 218 and 220 in first bonding layer 216 can include conductive materials including, but not limited to, W, Co, Cu, Al, or any combination thereof. In some embodiments, bonding contacts 218 and 220 are made of Cu for hybrid bonding.

[0053] As described above, the density of bonding contacts can affect the hybrid bonding. In addition to functional bonding contacts 218 that are necessary for electrical interconnections, the density of bonding contacts can be

increased to improve the hybrid bonding yield and strength by adding dummy bonding contacts 220 in first bonding layer 216. In some embodiments, to maximize the bonding contact density in first bonding layer 216, each of interconnects 212 and 214 is in contact with a respective one of bonding contacts 218 and 220. For example, interconnects 212 and 214 in first interconnect layer 210 and bonding contacts 218 and 220 in first bonding layer 216 have a one-to-one mapping relationship, and the number of bonding contacts 218 and 220 in first bonding layer 216 is the same as the number of interconnects 212 and 214 in first interconnect layer 210. Each interconnect 212 or 214 can act as an etch stop layer for forming corresponding bonding contact 218 or 220. In the areas without underneath interconnects 212 and 214, no bonding contact 218 or 220 is formed due to the lack of underneath etch stop layers (and all the bonding contacts 218 and 220 in first bonding layer 216 are formed by a single patterning process), according to some embodiments.

[0054] First bonding layer 216 can further include dielectrics 221 between and electrically isolating bonding contacts 218 and 220. Dielectrics 221 in first bonding layer 216 can include dielectric materials including, but not limited to, silicon oxide, silicon nitride, silicon oxynitride, low-k dielectrics, or any combination thereof. In some embodiments, dielectrics 221 are made of silicon oxide for hybrid bonding.

[0055] On the opposite side of bonding interface 203, second semiconductor structure 204 can also include a second interconnect layer 224 below second device layer 222. Second interconnect layer 224 includes interconnects 226 and 228 in one or more ILD layers, according to some embodiments. Two types of interconnects 226 and 228 can be formed in second interconnect layer 224 depending on their functionalities. In some embodiments, each interconnect 226 is a functional MEOL or BEOL interconnect (e.g., interconnect line or via contact) that is electrically connected to both first device layer 208 of first semiconductor structure 202 and second device layer 222 of second semiconductor structure 204 to transfer electrical signals across bonding interface 203 and between first and second semiconductor structure 202 and 204. Interconnect 228 can be a functional MEOL or BEOL interconnect (e.g., interconnect line or via contact) that is electrically connected to second device layer 222 of second semiconductor structure 204, but not first device layer 208 of first semiconductor structure 202, to transfer electrical signals within second semiconductor structure 204. In some embodiments, interconnect 228 is a dummy interconnect that is not electrically connected to second device layer 222 of second semiconductor structure 204. Interconnects 226 and 228 in second interconnect layer 224 can include conductive materials including, but not limited to, W, Co, Cu, Al, silicides, or any combination thereof. The ILD layers in second interconnect layer 224 can include dielectric materials including, but not limited to, silicon oxide, silicon nitride, silicon oxynitride, low-k dielectrics, or any combination thereof.

[0056] Second semiconductor structure 204 can further include a second bonding layer 230 below second interconnect layer 224. Second bonding layer 230 includes bonding contacts 232, 234, and 236 in two ILD layers, according to some embodiments. Different from first bonding layer 216, second bonding layer 230 can be formed by two patterning processes (e.g., two photolithography and development pro-

cesses). As a result, bonding contacts **232**, **234**, and **236** in second bonding layer **230** can be formed in various designs. In some embodiments, bonding contacts **232** are dual damascene contacts, while bonding contacts **234** and **236** are single damascene contacts. For example, by two patterning processes, bonding contact **232** can include a first portion **232-1** having a first critical dimension in one ILD layer and a second portion **232-2** having a second critical dimension different from the first critical dimension in another ILD layer. As shown in FIG. 2A, first portion **232-1** of bonding contact **232** can be in contact with corresponding interconnect **226** in second interconnect layer **224**, and second portion **232-2** of bonding contact **232** can be in contact with corresponding bonding contact **218** on the opposite side of bonding interface **203**. Bonding contact **232** thus can be in contact with corresponding interconnect **226** in second interconnect layer **224**. In contrast, bonding contacts **234** and **236** each does not include a first portion in contact with any interconnect in second interconnect layer **224**, thereby being separated from interconnects **226** and **228** in second interconnect layer **224**.

[0057] Two types of bonding contacts **232**, **234**, and **236** can be formed in second bonding layer **230** depending on whether it is part of an electrical connection between first and second semiconductor structures **202** and **204**. In some embodiments, each bonding contact **232** is a functional bonding contact that is part of an electrical connection across bonding interface **203** and between first and second semiconductor structures **202** and **204**. In some embodiments, bonding contact **234** or **236** is a dummy bonding contact that is not part of an electrical connection across bonding interface **203** and between first and second semiconductor structures **202** and **204**. Bonding contacts **232**, **234**, and **236** in second bonding layer **230** can include conductive materials including, but not limited to, W, Co, Cu, Al, or any combination thereof. In some embodiments, bonding contacts **232**, **234**, and **236** are made of Cu for hybrid bonding.

[0058] As described above, the density of bonding contacts can affect the hybrid bonding. In addition to functional bonding contacts **232** that are necessary for electrical interconnections, the density of bonding contacts can be increased to improve the hybrid bonding yield and strength by adding dummy bonding contacts **234** in second bonding layer **230**, which can form a high strength Cu—Cu fusion bonding with corresponding dummy bonding contacts **220** at bonding interface **203**. In some cases, dummy bonding contact **236** in second bonding layer **230** may not have a corresponding dummy bonding contact in first bonding layer **216** on the opposite side of bonding interface **203** due to the lack of an underneath interconnect in first interconnect layer **210** to act as the etch stop layer. As a result, a Cu—SiO<sub>2</sub> bonding may be formed between dummy bonding contact **236** and dielectric **221** as well. That is, each bonding contact **218** or **220** in first bonding layer **216** is in contact with a respective bonding contact **232** or **234** in second bonding layer **230** across bonding interface **203**, while one or more bonding contacts (e.g., dummy bonding contact **236**) in second bonding layer **230** is not in contact with any bonding contact in first bonding layer **216**, according to some embodiments. Thus, in some embodiments, the number of bonding contacts **232**, **234**, and **236** in second bonding layer **230** is greater than the number of bonding contacts **218** and **220** in first bonding layer **216**.

[0059] Second bonding layer **230** can further include dielectrics **237** between and electrically isolating bonding contacts **232**, **234**, and **236**. Dielectrics **237** in second bonding layer **230** can include dielectric materials including, but not limited to, silicon oxide, silicon nitride, silicon oxynitride, low-k dielectrics, or any combination thereof. In some embodiments, dielectrics **237** are made of silicon oxide for hybrid bonding.

[0060] As shown in FIG. 2A, in bonded structure **200**, a pair of functional bonding contacts **218** and **232** can be in contact with one another at bonding interface **203** and also in contact with a pair of interconnects **212** and **226** on opposite sides of bonding interface **203**, respectively, to electrically connect the pair of interconnects **212** and **226**. An electrical connection can thus be formed between the pair of interconnects **212** and **226** by the pair of functional bonding contacts **218** and **232**. The pair of functional bonding contacts **218** and **232** also form a high strength Cu—Cu fusion bonding at bonding interface **203**, according to some embodiments. On the other hand, in some embodiments, a pair of dummy bonding contacts **220** and **234** are in contact with one another at bonding interface **203** to form a high strength Cu—Cu fusion bonding at bonding interface **203** as well. The pair of dummy bonding contacts **220** and **234** are in contact with interconnect **214** (by dummy bonding contact **220**) on one side of bonding interface **203** but separated from any interconnect **226** or **228** on the opposite side of bonding interface **203**, according to some embodiments, thereby avoiding forming an electrical connection between interconnects across bonding interface **203**. In some embodiments, at least one dummy bonding contact **236** is separated from any bonding contact **218** or **220** at bonding interface **203**, and a pair of dummy bonding contact **236** and dielectric **221** thus form a Cu—SiO<sub>2</sub> bonding at bonding interface **203**. In some embodiments, the remaining areas of first and second bonding layers **216** and **230**, e.g., dielectrics **221** and **237**, form SiO<sub>2</sub>—SiO<sub>2</sub> covalent bonding at bonding interface **203**.

[0061] FIG. 2B illustrates a bonded structure **201** that is similar to bonded structure **200** illustrated in FIG. 2A except that the relative vertical positions of the components in first and second semiconductor structures **202** and **204** are switched. In other words, bonded structure **200** (except substrate **206**) can be flipped vertically along bonding interface **203** to become bonded structure **201**. Nevertheless, dummy bonding contacts can be added to bonded structures **200** and **201** to increase bonding contacts density (and Cu—Cu fusion bonding in some embodiments) at bonding interface **203** to achieve better bonding performance. The design and arrangement of dummy bonding contacts can accommodate the reduction of total patterning processes in forming the dummy bonding contacts, thereby reducing the fabrication cost. For example, on one side of bonding interface **203**, the bonding contacts can be all single damascene contacts formed by a single patterning process.

[0062] FIG. 3 illustrates a cross-section of an exemplary bonded structure **300** including dummy bonding contacts and dummy interconnects, according to some embodiments of the present disclosure. Different from bonded structures **200** and **201** in which bonding contacts on only one side of the bonding interface are single damascene contacts formed by a single patterning process, in bonded structure **300** in FIG. 3, bonding contacts on both sides of a bonding interface **303** between a first semiconductor structure **302** and a

second semiconductor structure 304 can be single damascene contacts formed by a single patterning process. By further reducing the number of patterning processes for forming the bonding contacts, the fabrication cost can be further decreased.

[0063] As shown in FIG. 3, first semiconductor structure 302 is disposed below second semiconductor structure 304 in bonded structure 300 and includes a substrate 306, according to some embodiments. First semiconductor structure 302 can also include a first device layer 308 above substrate 306. In some embodiments, first semiconductor structure 302 is a peripheral device chip or a memory array device chip, and first device layer 308 includes a peripheral device or a NAND memory string, respectively, as described above in FIG. 1. Similarly, second semiconductor structure 304 can include a second device layer 322. In some embodiments, second semiconductor structure 304 is a memory array device chip or a peripheral device chip, and second device layer 322 includes a NAND memory string or a peripheral device, respectively, as described above in FIG. 1.

[0064] First semiconductor structure 302 can also include a first interconnect layer 310 above first device layer 308. First interconnect layer 310 includes interconnects 312 and 314 in one or more ILD layers, according to some embodiments. Two types of interconnects 312 and 314 can be formed in first interconnect layer 310 depending on their functionalities. In some embodiments, each interconnect 312 is a functional MEOL or BEOL interconnect (e.g., interconnect line or via contact) that is electrically connected to both first device layer 308 of first semiconductor structure 302 and second device layer 322 of second semiconductor structure 304 to transfer electrical signals across bonding interface 303 and between first and second semiconductor structure 302 and 304. In some embodiments, each interconnect 314 is a dummy interconnect that is not electrically connected to first device layer 308 (and the peripheral device or NAND memory string therein for example) of first semiconductor structure 302. As described below in detail, dummy interconnects 314 can be added into first interconnect layer 310 in order to allow more dummy bonding contacts to be formed thereabove, thereby further increasing the bonding contact density at bonding interface 303. Interconnects 312 and 314 in first interconnect layer 310 can include conductive materials including, but not limited to, W, Co, Cu, Al, silicides, or any combination thereof. The ILD layers in first interconnect layer 310 can include dielectric materials including, but not limited to, silicon oxide, silicon nitride, silicon oxynitride, low-k dielectrics, or any combination thereof.

[0065] First semiconductor structure 302 can further include a first bonding layer 316 above first interconnect layer 310. First bonding layer 316 includes bonding contacts 318 and 320 in one ILD layer, according to some embodiments. To reduce the fabrication cost, first bonding layer 316 can be formed by a single patterning process (e.g., involving only one photolithography and development process) in a single ILD layer. As a result, in some embodiments, each bonding contact 318 or 320 has a nominally same critical dimension (e.g., the diameter of a via contact). In some embodiments, each bonding contact 318 or 320 is a single damascene contact, as opposed to a dual damascene contact. Two types of bonding contacts 318 and 320 can be formed in first bonding layer 316 depending on whether it is part of an electrical connection between first and second semicon-

ductor structures 302 and 304. In some embodiments, each bonding contact 318 is a functional bonding contact that is in contact with corresponding functional interconnect 312 and that is part of an electrical connection across bonding interface 303 and between first and second semiconductor structures 302 and 304. In some embodiments, bonding contact 320 is a dummy bonding contact that is in contact with corresponding dummy interconnect 314 and that is not part of an electrical connection across bonding interface 303 and between first and second semiconductor structures 302 and 304. Bonding contacts 318 and 320 in first bonding layer 316 can include conductive materials including, but not limited to, W, Co, Cu, Al, or any combination thereof. In some embodiments, bonding contacts 318 and 320 are made of Cu for hybrid bonding.

[0066] As described above, the density of bonding contacts can affect the hybrid bonding. In addition to functional bonding contacts 318 that are necessary for electrical interconnections, the density of bonding contacts can be increased to improve the hybrid bonding yield and strength by adding dummy interconnects 314 in first interconnect layer 310 and corresponding dummy bonding contacts 320 in first bonding layer 316. In some embodiments, to maximize the bonding contact density in first bonding layer 316, each of interconnects 312 and 314 is in contact with a respective one of bonding contacts 318 and 320. For example, interconnects 312 and 314 in first interconnect layer 310 and bonding contacts 318 and 320 in first bonding layer 316 have a one-to-one mapping relationship, and the number of bonding contacts 318 and 320 in first bonding layer 316 is the same as the number of interconnects 312 and 314 in first interconnect layer 310. Each interconnect 312 or 314 can act as an etch stop layer for forming corresponding bonding contact 318 or 320. In the areas without underneath interconnects 312 and 314, no bonding contact 318 or 320 is formed due to the lack of underneath etch stop layers (and all the bonding contacts 318 and 320 in first bonding layer 316 are formed by a single patterning process), according to some embodiments.

[0067] First bonding layer 316 can further include dielectrics 321 between and electrically isolating bonding contacts 318 and 320. Dielectrics 321 in first bonding layer 316 can include dielectric materials including, but not limited to, silicon oxide, silicon nitride, silicon oxynitride, low-k dielectrics, or any combination thereof. In some embodiments, dielectrics 321 are made of silicon oxide for hybrid bonding.

[0068] On the opposite side of bonding interface 303, second semiconductor structure 304 can also include a second interconnect layer 324 below second device layer 322. Second interconnect layer 324 includes interconnects 326 and 328 in one or more ILD layers, according to some embodiments. Two types of interconnects 326 and 328 can be formed in second interconnect layer 324 depending on their functionalities. In some embodiments, each interconnect 326 is a functional MEOL or BEOL interconnect (e.g., interconnect line or via contact) that is electrically connected to both first device layer 308 of first semiconductor structure 302 and second device layer 322 of second semiconductor structure 304 to transfer electrical signals across bonding interface 303 and between first and second semiconductor structure 302 and 304. In some embodiments, each interconnect 328 is a dummy interconnect that is not electrically connected to second device layer 322 (and the peripheral

device or NAND memory string therein for example) of second semiconductor structure 304. As described below in detail, dummy interconnects 328 can be added into second interconnect layer 324 in order to allow more dummy bonding contacts to be formed therebelow, thereby further increasing the bonding contact density at bonding interface 303. Interconnects 326 and 328 in second interconnect layer 324 can include conductive materials including, but not limited to, W, Co, Cu, Al, silicides, or any combination thereof. The ILD layers in second interconnect layer 324 can include dielectric materials including, but not limited to, silicon oxide, silicon nitride, silicon oxynitride, low-k dielectrics, or any combination thereof.

[0069] Second semiconductor structure 304 can further include a second bonding layer 330 below second interconnect layer 324. Different from second bonding layer 230 in FIGS. 2A and 2B having two ILD layers, second bonding layer 330 includes bonding contacts 332 and 334 in one ILD layer, according to some embodiments. To reduce the fabrication cost, second bonding layer 330 can be formed by a single patterning process (e.g., involving only one photolithography and development process) in a single ILD layer as well, just like first bonding layer 316 on the opposite side of bonding interface 303. As a result, in some embodiments, each bonding contact 332 or 334 has a nominally same critical dimension (e.g., the diameter of a via contact). In some embodiments, each bonding contact 332 or 334 is a single damascene contact, as opposed to a dual damascene contact. Two types of bonding contacts 332 and 334 can be formed in second bonding layer 330 depending on whether it is part of an electrical connection between first and second semiconductor structures 302 and 304. In some embodiments, each bonding contact 332 is a functional bonding contact that is in contact with corresponding functional interconnect 326 and that is part of an electrical connection across bonding interface 303 and between first and second semiconductor structures 302 and 304. In some embodiments, bonding contact 334 is a dummy bonding contact that is in contact with corresponding dummy interconnect 328 and that is not part of an electrical connection across bonding interface 303 and between first and second semiconductor structures 302 and 304. Bonding contacts 332 and 334 in second bonding layer 330 can include conductive materials including, but not limited to, W, Co, Cu, Al, or any combination thereof. In some embodiments, bonding contacts 332 and 334 are made of Cu for hybrid bonding.

[0070] As described above, the density of bonding contacts can affect the hybrid bonding. In addition to functional bonding contacts 332 that are necessary for electrical interconnections, the density of bonding contacts can be increased to improve the hybrid bonding yield and strength by adding dummy interconnects 328 in second interconnect layer 324 and corresponding dummy bonding contacts 334 in second bonding layer 330. In some embodiments, to maximize the bonding contact density in second bonding layer 330, each of interconnects 326 and 328 is in contact with a respective one of bonding contacts 332 and 334. For example, interconnects 326 and 328 in second interconnect layer 324 and bonding contacts 332 and 334 in second bonding layer 330 have a one-to-one mapping relationship, and the number of bonding contacts 332 and 334 in second bonding layer 330 is the same as the number of interconnects 326 and 328 in second interconnect layer 324. Each interconnect 326 or 328 can act as an etch stop layer for forming

corresponding bonding contact 332 or 334. In the areas without underneath interconnects 326 and 328, no bonding contact 332 or 334 is formed due to the lack of underneath etch stop layers (and all the bonding contacts 332 and 334 in second bonding layer 330 are formed by a single patterning process), according to some embodiments.

[0071] Second bonding layer 330 can further include dielectrics 335 between and electrically isolating bonding contacts 332 and 334. Dielectrics 335 in second bonding layer 330 can include dielectric materials including, but not limited to, silicon oxide, silicon nitride, silicon oxynitride, low-k dielectrics, or any combination thereof. In some embodiments, dielectrics 335 are made of silicon oxide for hybrid bonding.

[0072] Different from FIGS. 2A and 2B in which the number of bonding contacts in second bonding layer 230 (formed by two patterning processes) may be greater than the number of bonding contacts in first bonding layer 216 (formed by a single patterning process), in FIG. 3, the number of bonding contacts 332 and 334 in second bonding layer 330 (formed by a single patterning process) is the same as the number of bonding contacts in first bonding layer 316 (formed by a single patterning process). Each bonding contact 318 or 320 in first bonding layer 316 can be in contact with a respective bonding contact 332 or 334 in second bonding layer 330 at bonding interface 303. In other words, the bonding contacts on the opposite sides of bonding interface 303 have a one-to-one mapping relationship, according to some embodiments. Because functional bonding contacts 318 and 332 are paired and dummy bonding contacts 320 and 334 are paired as well, no bonding contact can be paired with dielectrics 321 or 335 to form, for example, a Cu—SiO<sub>2</sub> bonding. Consequently, the number of high strength Cu—Cu bondings can be further increased at bonding interface 303 to improve the bonding performance.

[0073] As shown in FIG. 3, in bonded structure 300, a pair of functional bonding contacts 318 and 332 can be in contact with one another at bonding interface 303 and also in contact with a pair of functional interconnects 312 and 326 on opposite sides of bonding interface 303, respectively, to electrically connect the pair of functional interconnects 312 and 326. An electrical connection can thus be formed between the pair of functional interconnects 312 and 326 by the pair of functional bonding contacts 318 and 332. The pair of functional bonding contacts 318 and 332 also form a high strength Cu—Cu fusion bonding at bonding interface 303, according to some embodiments. On the other hand, in some embodiments, a pair of dummy bonding contacts 320 and 334 are in contact with one another at bonding interface 303 to form a high strength Cu—Cu fusion bonding at bonding interface 303 as well. The pair of dummy bonding contacts 320 and 334 are in contact with a pair of dummy interconnects 314 and 328 on opposite sides of bonding interface 303, according to some embodiments. In some embodiments, the remaining areas of first and second bonding layers 316 and 330, e.g., dielectrics 321 and 335, form a SiO<sub>2</sub>—SiO<sub>2</sub> covalent bonding at bonding interface 303.

[0074] By introducing dummy interconnects 314 and 328 on both sides of bonding interface 303, the flexibility of arranging dummy bonding contacts 320 and 332 can be increased. In some embodiments, to further increase the hybrid bonding yield and strength, bonding contacts on each side of bonding interface 303 are nominally evenly disposed at bonding interface 303 in a plan view (not shown). In some

embodiments, the local density and/or global density of bonding contacts can be adjusted to accommodate various designs of bonded structure **300** by adding paired dummy interconnects and dummy contacts accordingly.

**[0075]** It is understood that bonded structure **200**, **201**, or **300** can include or be combined with other structures, such as device layer(s), interconnect layer(s), and substrate(s), to form any suitable semiconductor devices, for example, logic devices, volatile memory devices (e.g., dynamic random-access memory (DRAM) and static random-access memory (SRAM)), and non-volatile memory devices (e.g., Flash memory), in a 2D, 2.5D, or 3D architecture.

**[0076]** FIGS. 4A and 4B illustrate an exemplary fabrication process for forming a first semiconductor structure including dummy bonding contacts, according to some embodiments of the present disclosure. FIGS. 5A-5C illustrate an exemplary fabrication process for forming a second semiconductor structure including dummy bonding contacts, according to some embodiments of the present disclosure. FIG. 6 illustrates an exemplary fabrication process for bonding the first semiconductor structure and the second semiconductor structure, according to some embodiments of the present disclosure. FIG. 10 is a flowchart of a method for forming an exemplary bonded semiconductor device including dummy bonding contacts, according to some embodiments of the present disclosure. Examples of the bonded semiconductor device depicted in FIGS. 4-6 and 10 include bonded structures **200** and **201** depicted in FIGS. 2A and 2B. FIGS. 4-6 and 10 will be described together. It is understood that the operations shown in method **1000** are not exhaustive and that other operations can be performed as well before, after, or between any of the illustrated operations. Further, some of the operations may be performed simultaneously, or in a different order than shown in FIGS. 4-6 and 10.

**[0077]** Referring to FIG. 10, method **1000** starts at operation **1002**, in which a first interconnect layer including a plurality of first interconnects is formed above a first substrate. The first substrate can be a silicon substrate. In some embodiments, a first device layer is formed between the first substrate and the first interconnect layer prior to forming the first interconnect layer. The first device layer can include a NAND memory string or a peripheral device.

**[0078]** As illustrated in FIG. 4A, a first device layer **404** is formed above a silicon substrate **402**. In some embodiments, first device layer **404** is a peripheral device layer including a plurality of transistors (not shown) formed on silicon substrate **402** by a plurality of processes including, but not limited to, photolithography, dry/wet etch, thin film deposition, thermal growth, implantation, CMP, and any other suitable processes.

**[0079]** In some embodiments, first device layer **404** is a memory array device layer including a plurality of NAND memory strings (not shown) each extending vertically through a memory stack (not shown) formed on silicon substrate **402**. To form the memory stack, a dielectric stack including an alternating stack of sacrificial layers (e.g., silicon nitride) and dielectric layers (e.g., silicon oxide) can be formed on silicon substrate **402** by one or more thin film deposition processes including, but not limited to, CVD, physical vapor deposition (PVD), atomic layer deposition (ALD), or any combination thereof. The memory stack then can be formed on silicon substrate **402** by gate replacement processes, i.e., replacing the sacrificial layers in the dielectric stack with conductor layers. In some embodiments,

fabrication processes to form the NAND memory strings include forming a semiconductor channel that extends vertically through the dielectric stack, forming a composite dielectric layer (memory film) between the semiconductor channel and the dielectric stack, including, but not limited to, a tunneling layer, a storage layer, and a blocking layer. The semiconductor channel and the memory film can be formed by one or more thin film deposition processes such as ALD, CVD, PVD, any other suitable processes, or any combination thereof.

**[0080]** As illustrated in FIG. 4A, a first interconnect layer **406** is formed above first device layer **404**. First interconnect layer **406** can include interconnects **408** and **410**, including interconnect lines and via contacts in one or more ILD layers, to make electrical connections with first device layer **404**. In some embodiments, first interconnect layer **406** includes multiple ILD layers and interconnects therein formed by multiple processes. For example, interconnects **408** and **410** can include conductive materials deposited by one or more thin film deposition processes including, but not limited to, CVD, PVD, ALD, electrochemical depositions, or any combination thereof. The ILD layers can include dielectric materials deposited by one or more thin film deposition processes including, but not limited to, CVD, PVD, ALD, or any combination thereof.

**[0081]** Method **1000** proceeds to operation **1004**, as illustrated in FIG. 6, in which a first bonding layer including a plurality of first bonding contacts is formed above the first interconnect layer, such that each of the first interconnects is in contact with a respective one of the first bonding contacts. A first dielectric can be formed in the first bonding layer as well. In some embodiments, the first bonding contacts in the first bonding layers are formed by a single patterning process. In some embodiments, the number of the first bonding contacts is the same as the number of first interconnects. Each of the first bonding contacts has a nominally same critical dimension, according to some embodiments.

**[0082]** As illustrated in FIG. 4B, a layer of dielectric **411** is deposited on the top surface of first interconnect layer **406** by a thin film deposition process including, but not limited to, CVD, PVD, ALD, or any combination thereof. Bonding contacts **414** and **416** are formed in dielectric **411** to form a first bonding layer **412** above first interconnect layer **406** and first device layer **404**, according to some embodiments. Bonding contact **414** and **416** can be patterned by a single patterning process involving only one photolithography process. In some embodiments, etch masks (photoresist and/or hard masks) are patterned by a single patterning process to expose dielectric **411** only at the areas where interconnects **408** and **410** are formed underneath. Opening (e.g., a via hole and/or a trench) then can be etched through first bonding layer **412** until being stopped by underneath interconnects **408** and **410** as etch stop layers using dry etch and/or wet etch. Bonding contacts **414** and **416** can include a barrier/adhesion layer and a conductor (e.g., a metal) deposited subsequently in this order by one or more thin film deposition processes including, but not limited to, CVD, PVD, ALD, electrochemical depositions, or any combination thereof, to fill the openings. The excess conductor can be removed by CMP, and the top surface of first bonding layer **412** can be planarized for bonding.

**[0083]** Method **1000** proceeds to operation **1006**, as illustrated in FIG. 10, in which a second interconnect layer including a plurality of second interconnects is formed

above a second substrate. The second substrate can be a silicon substrate. In some embodiments, a second device layer is formed between the second substrate and the second interconnect layer prior to forming the second interconnect layer. The second device layer can include a peripheral device or a NAND memory string.

**[0084]** As illustrated in FIG. 5A, a second device layer 504 is formed above a silicon substrate 502. In some embodiments, second device layer 504 is a memory array device layer including a plurality of NAND memory strings (not shown) each extending vertically through a memory stack (not shown) formed on silicon substrate 502. The details of forming the memory array device layer are described above and will not be repeated. In some embodiments, second device layer 504 is a peripheral device layer including a plurality of transistors (not shown) formed on silicon substrate 502 by a plurality of processes including, but not limited to, photolithography, dry/wet etch, thin film deposition, thermal growth, implantation, CMP, and any other suitable processes.

**[0085]** As illustrated in FIG. 5A, a second interconnect layer 506 is formed above second device layer 504. Second interconnect layer 506 can include interconnects 508, including interconnect lines and via contacts in one or more ILD layers, to make electrical connections with second device layer 504. In some embodiments, second interconnect layer 506 includes multiple ILD layers and interconnects therein formed by multiple processes. For example, interconnects 508 can include conductive materials deposited by one or more thin film deposition processes including, but not limited to, CVD, PVD, ALD, electrochemical depositions, or any combination thereof. The ILD layers can include dielectric materials deposited by one or more thin film deposition processes including, but not limited to, CVD, PVD, ALD, or any combination thereof.

**[0086]** Method 1000 proceeds to operation 1008, as illustrated in FIG. 10, in which a second bonding layer including a plurality of second bonding contacts is formed above the second interconnect layer, such that at least one of the second bonding contacts is in contact with a respective one of the second interconnects, and at least another one of the second bonding contacts is separated from the second interconnects. A second dielectric can be formed in the second bonding layer as well. In some embodiments, the second bonding contacts in the second bonding layers are formed by two patterning processes. In some embodiments, to form the second bonding layer, first portions of second bonding contacts are formed above the second interconnects by one of the two patterning processes, and second portions of second bonding contacts are formed above the first portions of second bonding contacts by another one of the two patterning processes. The number of the second portions of second bonding contacts is greater than the number of the first portions of second bonding contacts, according to some embodiments.

**[0087]** As illustrated in FIG. 5B, a first layer of dielectric 509 is deposited on the top surface of second interconnect layer 506 by a thin film deposition process including, but not limited to, CVD, PVD, ALD, or any combination thereof. First portions of bonding contact 512-1 are formed in dielectric 509 to form a first bonding sub-layer 510-1 above second interconnect layer 506 and second device layer 504, according to some embodiments. First portions of bonding contact 512-1 can be patterned by a first patterning process

involving one photolithography process. In some embodiments, etch masks (photoresist and/or hard masks) are patterned by the first patterning process to expose dielectric 509 only at the areas where cross-chip electrical connections are to be formed. Opening (e.g., a via hole and/or a trench) then can be etched through first bonding sub-layer 510-1 until being stopped by underneath interconnects 508 as etch stop layers using dry etch and/or wet etch. First portions of bonding contact 512-1 can include a barrier/adhesion layer and a conductor (e.g., a metal) deposited subsequently in this order by one or more thin film deposition processes including, but not limited to, CVD, PVD, ALD, electrochemical depositions, or any combination thereof, to fill the openings. The excess conductor can be removed by CMP, and the top surface of first bonding sub-layer 510-1 can be planarized.

**[0088]** As illustrated in FIG. 5C, a second layer of dielectric 511 is deposited on the top surface of first bonding sub-layer 510-1 by a thin film deposition process including, but not limited to, CVD, PVD, ALD, or any combination thereof. Second portions of bonding contact 512-2 and 514 are formed in dielectric 511 to form a second bonding sub-layer 510-2 above first bonding sub-layer 510-1, according to some embodiments. First and second bonding sub-layers 510-1 and 510-2 can together be referred to here as a second bonding layer 510. Second portions of bonding contact 512-2 and 514 can be patterned by a second patterning process involving one photolithography process. In some embodiments, etch masks (photoresist and/or hard masks) are patterned by the second patterning process to expose dielectric 511 at the areas where first portions of bonding contacts 512-1 are formed underneath, such that first and second portions of bonding contacts 512-1 and 512-2 can together form a functional bonding contact electrically connected to underneath interconnects 508. Additionally, etch masks (photoresist and/or hard masks) can be patterned by the second patterning process to expose dielectric 511 at the areas where dummy bonding contacts 514 can be formed to increase the bonding performance. Opening (e.g., a via hole and/or a trench) then can be etched through second bonding sub-layer 510-2 using dry etch and/or wet etch. Second portions of bonding contacts 512-2 and 514 can include a barrier/adhesion layer and a conductor (e.g., a metal) deposited subsequently in this order by one or more thin film deposition processes including, but not limited to, CVD, PVD, ALD, electrochemical depositions, or any combination thereof, to fill the openings. The excess conductor can be removed by CMP, and the top surface of second bonding layer 510 can be planarized for bonding.

**[0089]** Method 1000 proceeds to operation 1010, as illustrated in FIG. 10, in which the first substrate and the second substrate are bonded in a face-to-face manner, such that each of the first bonding contacts is in contact with one of the second bonding contacts at a bonding interface. The first dielectric can be in contact with the second dielectric as well after the bonding. The bonding can be hybrid bonding.

**[0090]** As illustrated in FIG. 6, silicon substrate 502 and second device layer 504 formed thereon are flipped upside down. Second bonding layer 510 facing down is to be bonded with first bonding layer 412 facing up, i.e., in a face-to-face manner. In some embodiments, bonding contacts 414 and 416 are aligned with bonding contacts 512 and 514 prior to hybrid bonding, such that each bonding contact 414 or 416 is in contact with one of bonding contacts 512 and 514 at a bonding interface after the hybrid bonding,

according to some embodiments. In some embodiments, a treatment process, e.g., a plasma treatment, a wet treatment, and/or a thermal treatment, is applied to the bonding surfaces prior to the hybrid bonding. As a result of the hybrid bonding, bonding contacts **414** and **416** can be inter-mixed with bonding contacts **512** and **514**, and dielectric **411** can be covalent-bonded with dielectric **511**, thereby forming a bonding interface between first bonding layer **412** and second bonding layer **510**.

**[0091]** It is understood that although second bonding layer **510** is flipped upside down and is above first bonding layer **412** in the resulting bonded structure as shown in FIG. 6, in some embodiments, first bonding layer **412** is flipped upside down and is above second bonding layer **510** in the resulting bonded structure. In one example, first device layer **404** can be a peripheral device layer, and second device layer **504** can be a memory array device layer. In another example, first device layer **404** can be a memory array device layer, and second device layer **504** can be a peripheral device layer. In still another example, first and second device layers **404** and **504** can be both peripheral device layers. In yet another example, first and second device layers **404** and **504** can be both memory array device layers.

**[0092]** FIGS. 7A and 7B illustrate an exemplary fabrication process for forming a first semiconductor structure including dummy bonding contacts and dummy interconnects, according to some embodiments of the present disclosure. FIGS. 8A and 8B illustrate an exemplary fabrication process for forming a second semiconductor structure including dummy bonding contacts and dummy interconnects, according to some embodiments of the present disclosure. FIG. 9 illustrates another exemplary fabrication process for bonding the first semiconductor structure and the second semiconductor structure, according to some embodiments of the present disclosure. FIG. 11 is a flowchart of a method for forming an exemplary bonded semiconductor device including dummy bonding contacts and dummy interconnects, according to some embodiments of the present disclosure. Examples of the bonded semiconductor device depicted in FIGS. 7-9 and 11 include bonded structure **300** depicted in FIG. 3. FIGS. 7-9 and 11 will be described together. It is understood that the operations shown in method **1100** are not exhaustive and that other operations can be performed as well before, after, or between any of the illustrated operations. Further, some of the operations may be performed simultaneously, or in a different order than shown in FIGS. 7-9 and 11.

**[0093]** Referring to FIG. 11, method **1100** starts at operation **1102**, in which a first interconnect layer including a plurality of first interconnects is formed above a first substrate. The first substrate can be a silicon substrate. At least one of the first interconnects can be at least one first dummy interconnect. In some embodiments, a first device layer is formed between the first substrate and the first interconnect layer prior to forming the first interconnect layer. The first device layer can include a NAND memory string or a peripheral device. The first dummy interconnect is not electrically connected to the NAND memory string and the peripheral device, according to some embodiments.

**[0094]** As illustrated in FIG. 7A, a first device layer **704** is formed above a silicon substrate **702**. In some embodiments, first device layer **704** is a peripheral device layer including a plurality of transistors (not shown) formed on silicon substrate **702** by a plurality of processes including, but not

limited to, photolithography, dry/wet etch, thin film deposition, thermal growth, implantation, CMP, and any other suitable processes. In some embodiments, first device layer **704** is a memory array device layer including a plurality of NAND memory strings (not shown) each extending vertically through a memory stack (not shown) formed on silicon substrate **702**. The details of forming the memory array device layer are described above and will not be repeated.

**[0095]** As illustrated in FIG. 7A, a first interconnect layer **706** is formed above first device layer **704**. First interconnect layer **706** can include functional interconnects **708** and dummy interconnects **710**, including interconnect lines and via contacts in one or more ILD layers. Functional interconnects **708** make electrical connections with first device layer **704**, while dummy interconnects **710** are not electrically connected to first device layer **704**, according to some embodiments. In some embodiments, first interconnect layer **706** includes multiple ILD layers and interconnects therein formed by multiple processes. For example, interconnects **708** and **710** can include conductive materials deposited by one or more thin film deposition processes including, but not limited to, CVD, PVD, ALD, electrochemical depositions, or any combination thereof. The ILD layers can include dielectric materials deposited by one or more thin film deposition processes including, but not limited to, CVD, PVD, ALD, or any combination thereof.

**[0096]** Method **1100** proceeds to operation **1104**, as illustrated in FIG. 11, in which a first bonding layer including a plurality of first bonding contacts is formed above the first interconnect layer, such that each of the first interconnects is in contact with a respective one of the first bonding contacts. A first dielectric can be formed in the first bonding layer as well. In some embodiments, the first bonding contacts in the first bonding layers are formed by a single patterning process. In some embodiments, the number of the first bonding contacts is the same as the number of first interconnects. Each of the first bonding contacts has a nominally same critical dimension, according to some embodiments.

**[0097]** As illustrated in FIG. 7B, a layer of dielectric **711** is deposited on the top surface of first interconnect layer **706** by a thin film deposition process including, but not limited to, CVD, PVD, ALD, or any combination thereof. Functional bonding contacts **714** and dummy bonding contacts **716** are formed in dielectric **711** to form a first bonding layer **712** above first interconnect layer **706** and first device layer **704**, according to some embodiments. Bonding contacts **714** and **716** can be patterned by a single patterning process involving only one photolithography process. In some embodiments, etch masks (photoresist and/or hard masks) are patterned by a single patterning process to expose dielectric **711** only at the areas where interconnects **708** and **710** are formed underneath. Opening (e.g., a via hole and/or a trench) then can be etched through first bonding layer **712** until being stopped by underneath interconnects **708** and **710** as etch stop layers using dry etch and/or wet etch. Bonding contacts **714** and **716** can include a barrier/adhesion layer and a conductor (e.g., a metal) deposited subsequently in this order by one or more thin film deposition processes including, but not limited to, CVD, PVD, ALD, electrochemical depositions, or any combination thereof, to fill the openings. The excess conductor can be removed by CMP, and the top surface of first bonding layer **712** can be planarized for bonding.

[0098] Method 1100 proceeds to operation 1106, as illustrated in FIG. 11, in which a second interconnect layer including a plurality of second interconnects is formed above a second substrate. The second substrate can be a silicon substrate. At least one of the second interconnects can be at least one second dummy interconnect. In some embodiments, a second device layer is formed between the second substrate and the second interconnect layer prior to forming the second interconnect layer. The second device layer can include a NAND memory string or a peripheral device. The second dummy interconnect is not electrically connected to the NAND memory string and the peripheral device, according to some embodiments.

[0099] As illustrated in FIG. 8A, a second device layer 804 is formed above a silicon substrate 802. In some embodiments, second device layer 804 is a peripheral device layer including a plurality of transistors (not shown) formed on silicon substrate 802 by a plurality of processes including, but not limited to, photolithography, dry/wet etch, thin film deposition, thermal growth, implantation, CMP, and any other suitable processes. In some embodiments, second device layer 804 is a memory array device layer including a plurality of NAND memory strings (not shown) each extending vertically through a memory stack (not shown) formed on silicon substrate 802. The details of forming the memory array device layer are described above and will not be repeated.

[0100] As illustrated in FIG. 8A, a second interconnect layer 806 is formed above second device layer 804. Second interconnect layer 806 can include functional interconnects 808 and dummy interconnects 810, including interconnect lines and via contacts in one or more ILD layers. Functional interconnects 808 make electrical connections with second device layer 804, while dummy interconnects 810 are not electrically connected to second device layer 804, according to some embodiments. In some embodiments, second interconnect layer 806 includes multiple ILD layers and interconnects therein formed by multiple processes. For example, interconnects 808 and 810 can include conductive materials deposited by one or more thin film deposition processes including, but not limited to, CVD, PVD, ALD, electrochemical depositions, or any combination thereof. The ILD layers can include dielectric materials deposited by one or more thin film deposition processes including, but not limited to, CVD, PVD, ALD, or any combination thereof.

[0101] Method 1100 proceeds to operation 1108, as illustrated in FIG. 11, in which a second bonding layer including a plurality of second bonding contacts is formed above the second interconnect layer, such that each of the second interconnects is in contact with a respective one of the second bonding contacts. A second dielectric can be formed in the second bonding layer as well. In some embodiments, the second bonding contacts in the second bonding layers are formed by a single patterning process. In some embodiments, the number of the second bonding contacts is the same as the number of the second interconnects. Each of the second bonding contacts has a nominally same critical dimension, according to some embodiments. In some embodiments, the number of the second bonding contacts is the same as the number of the first bonding contacts.

[0102] As illustrated in FIG. 8B, a layer of dielectric 811 is deposited on the top surface of second interconnect layer 806 by a thin film deposition process including, but not limited to, CVD, PVD, ALD, or any combination thereof.

Functional bonding contacts 814 and dummy bonding contacts 816 are formed in dielectric 811 to form a second bonding layer 812 above second interconnect layer 806 and second device layer 804, according to some embodiments. Bonding contacts 814 and 816 can be patterned by a single patterning process involving only one photolithography process. In some embodiments, etch masks (photoresist and/or hard masks) are patterned by a single patterning process to expose dielectric 811 only at the areas where interconnects 808 and 810 are formed underneath. Opening (e.g., a via hole and/or a trench) then can be etched through second bonding layer 812 until being stopped by underneath interconnects 808 and 810 as etch stop layers using dry etch and/or wet etch. Bonding contacts 814 and 816 can include a barrier/adhesion layer and a conductor (e.g., a metal) deposited subsequently in this order by one or more thin film deposition processes including, but not limited to, CVD, PVD, ALD, electrochemical depositions, or any combination thereof, to fill the openings. The excess conductor can be removed by CMP, and the top surface of second bonding layer 812 can be planarized for bonding.

[0103] Method 1100 proceeds to operation 1110, as illustrated in FIG. 11, in which the first substrate and the second substrate are bonded in a face-to-face manner, such that each of the first bonding contacts is in contact with a respective one of the second bonding contacts at a bonding interface. The first dielectric can be in contact with the second dielectric as well after the bonding. The bonding can be hybrid bonding.

[0104] As illustrated in FIG. 9, silicon substrate 702 and first device layer 704 formed thereon are flipped upside down. First bonding layer 712 facing down is to be bonded with second bonding layer 812 facing up, i.e., in a face-to-face manner. In some embodiments, bonding contacts 714 and 716 are aligned with bonding contacts 814 and 816 prior to hybrid bonding, such that each bonding contact 714 or 716 is in contact with corresponding bonding contact 814 or 816 at a bonding interface after the hybrid bonding, according to some embodiments. In some embodiments, a treatment process, e.g., a plasma treatment, a wet treatment, and/or a thermal treatment, is applied to the bonding surfaces prior to the hybrid bonding. As a result of the hybrid bonding, bonding contacts 714 and 716 can be inter-mixed with bonding contacts 814 and 816, and dielectric 711 can be covalent-bonded with dielectric 811, thereby forming a bonding interface between first bonding layer 712 and second bonding layer 812.

[0105] According to one aspect of the present disclosure, a semiconductor device includes a first semiconductor structure and a second semiconductor structure. The first semiconductor structure includes a first interconnect layer including a plurality of first interconnects. At least one of the first interconnects is at least one first dummy interconnect. The first semiconductor structure further includes a first bonding layer including a plurality of first bonding contacts. Each of the first interconnects is in contact with a respective one of the first bonding contacts. The second semiconductor structure includes a second interconnect layer including a plurality of second interconnects. At least one of the second interconnects is at least one second dummy interconnect. The second semiconductor structure further includes a second bonding layer including a plurality of second bonding contacts. Each of the second interconnects is in contact with a respective one of the second bonding contacts. The semi-



conductor device further includes a bonding interface between the first bonding layer and the second bonding layer. Each of the first bonding contacts is in contact with a respective one of the second bonding contacts at the bonding interface.

**[0106]** In some embodiments, a number of the first bonding contacts is the same as a number of first interconnects, and a number of the first bonding contacts is the same as a number of the first interconnects.

**[0107]** In some embodiments, a number of the first dummy interconnects is the same as a number of the second dummy interconnects.

**[0108]** In some embodiments, each of the first bonding contacts has a nominally same first critical dimension, and each of the second bonding contacts has a nominally same second critical dimension.

**[0109]** In some embodiments, the first and second bonding contacts include a pair of dummy bonding contacts in contact with one another at the bonding interface, and the pair of dummy bonding contacts electrically connect a respective pair of first and second dummy interconnects.

**[0110]** In some embodiments, the first bonding layer further includes a first dielectric, and the second bonding layer further includes a second dielectric in contact with the first dielectric at the bonding interface.

**[0111]** In some embodiments, the first bonding contacts are nominally evenly disposed at the bonding interface, and the second bonding contacts are nominally evenly disposed at the bonding interface.

**[0112]** In some embodiments, one of the first semiconductor structure and the second semiconductor structure further includes a device layer having a NAND memory string, and another one of the first semiconductor structure and the second semiconductor structure further includes a device layer having a peripheral device.

**[0113]** In some embodiments, the first and second dummy interconnects are not electrically connected to the NAND memory string and the peripheral device.

**[0114]** According to another aspect of the present disclosure, a bonded structure includes a bonding interface, a pair of functional bonding contacts, and a pair of dummy bonding contacts. The pair of functional bonding contacts are in contact with one another at the bonding interface. The pair of bonding contacts are in contact with a pair of functional interconnects on opposite sides of the bonding interface, respectively. The pair of dummy bonding contacts are in contact with one another at the bonding interface. The pair of dummy bonding contacts are in contact with a pair of dummy interconnects on the opposite sides of the bonding interface, respectively.

**[0115]** In some embodiments, the bonded structure further includes a pair of dielectrics in contact with one another at the bonding interface.

**[0116]** According to still another aspect of the present disclosure, a method for forming a semiconductor device is disclosed. A first interconnect layer including a plurality of first interconnects is formed above a first substrate. At least one of the first interconnects is at least one first dummy interconnect. A first bonding layer including a plurality of first bonding contacts is formed above the first interconnect layer, such that each of the first interconnects is in contact with a respective one of the first bonding contacts. A second interconnect layer including a plurality of second interconnects is formed above a second substrate. At least one of the

second interconnects is at least one second dummy interconnect. A second bonding layer including a plurality of second bonding contacts is formed above the second interconnect layer, such that each of the second interconnects is in contact with a respective one of the second bonding contacts. The first substrate and the second substrate are bonded in a face-to-face manner, such that each of the first bonding contacts is in contact with a respective one of the second bonding contacts at a bonding interface.

**[0117]** In some embodiments, to form the first bonding layer, the first bonding contacts are formed by a single patterning process. In some embodiments, to form the second bonding layer, the second bonding contacts are formed by a single patterning process.

**[0118]** In some embodiments, a number of the first bonding contacts is the same as a number of first interconnects, and a number of the first bonding contacts is the same as a number of first interconnects.

**[0119]** In some embodiments, each of the first bonding contacts has a nominally same first critical dimension, and each of the second bonding contacts has a nominally same second critical dimension.

**[0120]** In some embodiments, to form the first bonding layer, a first dielectric is formed in the first bonding layer. In some embodiments, to form the second bonding layer, a second dielectric is formed in the second bonding layer. The first dielectric is in contact with the second dielectric at the bonding interface after the bonding, according to some embodiments.

**[0121]** In some embodiments, a first device layer having a NAND memory string is formed between the first interconnect layer and the first substrate, and a second device layer having a peripheral device between the second interconnect layer and the second substrate. The first and second dummy interconnects are not electrically connected to the NAND memory string and the peripheral device, according to some embodiments.

**[0122]** In some embodiments, a first device layer having a peripheral device is formed between the first interconnect layer and the first substrate, and a second device layer having a NAND memory string between the second interconnect layer and the second substrate. The first and second dummy interconnects are not electrically connected to the NAND memory string and the peripheral device, according to some embodiments.

**[0123]** In some embodiments, the bonding includes hybrid bonding.

**[0124]** The foregoing description of the specific embodiments will so reveal the general nature of the present disclosure that others can, by applying knowledge within the skill of the art, readily modify and/or adapt for various applications such specific embodiments, without undue experimentation, without departing from the general concept of the present disclosure. Therefore, such adaptations and modifications are intended to be within the meaning and range of equivalents of the disclosed embodiments, based on the teaching and guidance presented herein. It is to be understood that the phraseology or terminology herein is for the purpose of description and not of limitation, such that the terminology or phraseology of the present specification is to be interpreted by the skilled artisan in light of the teachings and guidance.

**[0125]** Embodiments of the present disclosure have been described above with the aid of functional building blocks

illustrating the implementation of specified functions and relationships thereof. The boundaries of these functional building blocks have been arbitrarily defined herein for the convenience of the description. Alternate boundaries can be defined so long as the specified functions and relationships thereof are appropriately performed.

**[0126]** The Summary and Abstract sections may set forth one or more but not all exemplary embodiments of the present disclosure as contemplated by the inventor(s), and thus, are not intended to limit the present disclosure and the appended claims in any way.

**[0127]** The breadth and scope of the present disclosure should not be limited by any of the above-described exemplary embodiments, but should be defined only in accordance with the following claims and their equivalents.

What is claimed is:

1. A semiconductor device, comprising:
  - a first semiconductor structure comprising:
    - a first interconnect layer comprising a plurality of first interconnects, at least one of the first interconnects being at least one first dummy interconnect; and
    - a first bonding layer comprising a plurality of first bonding contacts, each of the first interconnects being in contact with a respective one of the first bonding contacts;
  - a second semiconductor structure comprising:
    - a second interconnect layer comprising a plurality of second interconnects, at least one of the second interconnects being at least one second dummy interconnect; and
    - a second bonding layer comprising a plurality of second bonding contacts, each of the second interconnects being in contact with a respective one of the second bonding contacts; and
  - a bonding interface between the first bonding layer and the second bonding layer,
    - wherein each of the first bonding contacts is in contact with a respective one of the second bonding contacts at the bonding interface.
2. The semiconductor device of claim 1, wherein a number of the first bonding contacts is the same as a number of the first interconnects, and a number of the first bonding contacts is the same as a number of the first interconnects.
3. The semiconductor device of claim 1, wherein a number of the first dummy interconnects is the same as a number of the second dummy interconnects.
4. The semiconductor device of claim 1, wherein each of the first bonding contacts has a nominally same first critical dimension, and each of the second bonding contacts has a nominally same second critical dimension.
5. The semiconductor device of claim 1, wherein the first and second bonding contacts comprise a pair of dummy bonding contacts in contact with one another at the bonding interface, the pair of dummy bonding contacts electrically connecting a respective pair of first and second dummy interconnects.
6. The semiconductor device of claim 1, wherein the first bonding layer further comprises a first dielectric, and the second bonding layer further comprises a second dielectric in contact with the first dielectric at the bonding interface.
7. The semiconductor device of claim 1, wherein the first bonding contacts are nominally evenly disposed at the bonding interface, and the second bonding contacts are nominally evenly disposed at the bonding interface.

8. The semiconductor device of claim 1, wherein one of the first semiconductor structure and the second semiconductor structure further comprises a device layer having a NAND memory string, and another one of the first semiconductor structure and the second semiconductor structure further comprises a device layer having a peripheral device.

9. The semiconductor device of claim 8, wherein the first and second dummy interconnects are not electrically connected to the NAND memory string and the peripheral device.

10. A bonded structure, comprising:
  - a bonding interface;
  - a pair of functional bonding contacts in contact with one another at the bonding interface, wherein the pair of functional bonding contacts are in contact with a pair of functional interconnects on opposite sides of the bonding interface, respectively; and
  - a pair of dummy bonding contacts in contact with one another at the bonding interface, wherein the pair of dummy bonding contacts are in contact with a pair of dummy interconnects on the opposite sides of the bonding interface, respectively.
11. The bonding structure of claim 10, further comprising a pair of dielectrics in contact with one another at the bonding interface.

12. A method for forming a semiconductor device, comprising:
  - forming a first interconnect layer comprising a plurality of first interconnects above a first substrate, wherein at least one of the first interconnects is at least one first dummy interconnect;
  - forming a first bonding layer comprising a plurality of first bonding contacts above the first interconnect layer, such that each of the first interconnects is in contact with a respective one of the first bonding contacts;
  - forming a second interconnect layer comprising a plurality of second interconnects above a second substrate, wherein at least one of the second interconnects is at least one second dummy interconnect;
  - forming a second bonding layer comprising a plurality of second bonding contacts above the second interconnect layer, such that each of the second interconnects is in contact with a respective one of the second bonding contacts; and
  - bonding the first substrate and the second substrate in a face-to-face manner, such that each of the first bonding contacts is in contact with a respective one of the second bonding contacts at a bonding interface.
13. The method of claim 12, wherein forming the first bonding layer comprises forming the first bonding contacts by a single patterning process.
14. The method of claim 12, wherein forming the second bonding layer comprises forming the second bonding contacts by a single patterning process.
15. The method of claim 12, wherein a number of the first bonding contacts is the same as a number of first interconnects, and a number of the first bonding contacts is the same as a number of first interconnects.
16. The method of claim 12, wherein each of the first bonding contacts has a nominally same first critical dimension, and each of the second bonding contacts has a nominally same second critical dimension.

**17.** The method of claim **12**, wherein:  
forming the first bonding layer comprises forming a first dielectric in the first bonding layer;  
forming the second bonding layer comprises forming a second dielectric in the second bonding layer; and  
the first dielectric is in contact with the second dielectric at the bonding interface after the bonding.

**18.** The method of claim **12**, further comprising:  
forming a first device layer having a NAND memory string between the first interconnect layer and the first substrate; and  
forming a second device layer having a peripheral device between the second interconnect layer and the second substrate,  
wherein the first and second dummy interconnects are not electrically connected to the NAND memory string and the peripheral device.

**19.** The method of claim **12**, further comprising:  
forming a first device layer having a peripheral device between the first interconnect layer and the first substrate; and  
forming a second device layer having a NAND memory string between the second interconnect layer and the second substrate,  
wherein the first and second dummy interconnects are not electrically connected to the NAND memory string and the peripheral device.

**20.** The method of claim **12**, wherein the bonding comprises hybrid bonding.

\* \* \* \* \*