

Circ-Air™ Round Pit Aeration System

Farm Series Grain Bin Installation and Storage Instructions

Original Instructions

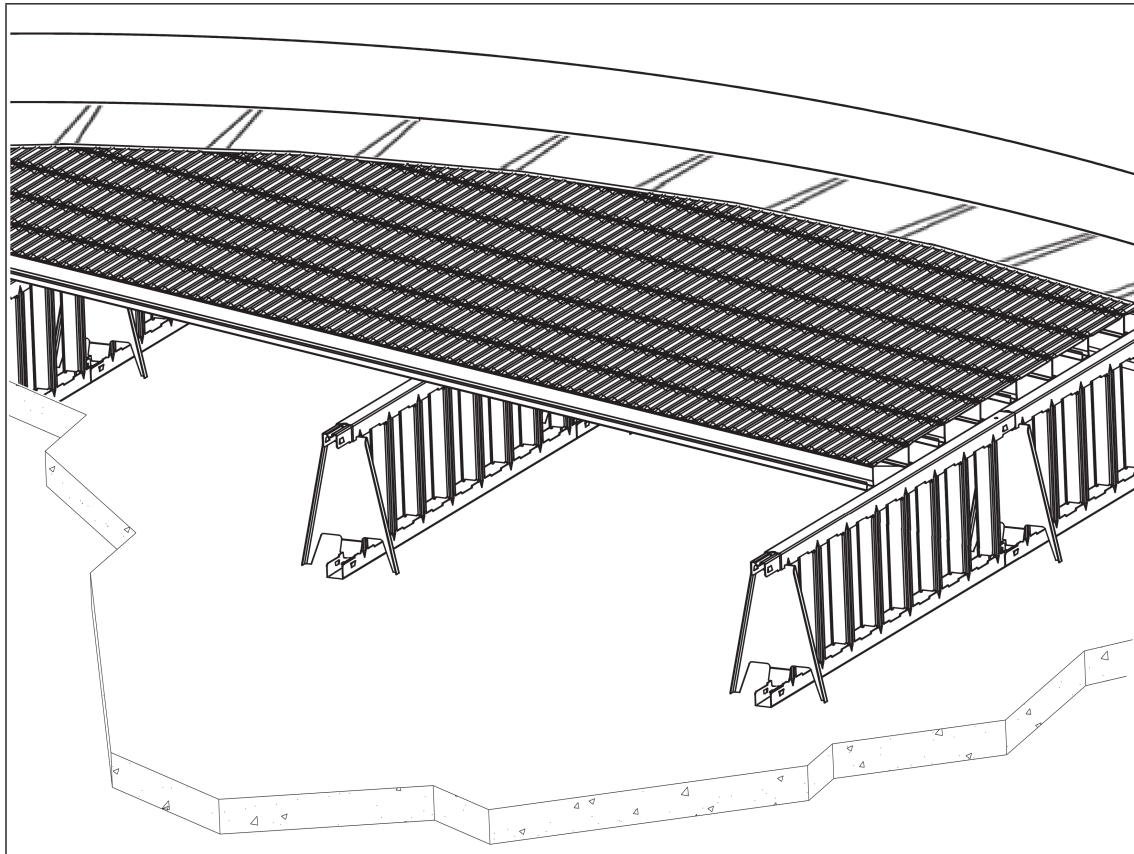

Read this manual before using product. Failure to follow instructions and safety precautions can result in serious injury, death, or property damage. Keep manual for future reference.

Part Number: 198827 R10

Revised: Nov 2018

New in this Manual

The following changes have been made in this revision of the manual:

Description	Section
Updated Safety Decal Locations	2.6. Safety Decal Locations and Details on page 7
Updated the foundation sectional view.	Section 5.2. – Foundation Planning and Specification on page 17
Modified the installation instructions for fan duct, unloading auger, and fan transition.	Section 5.4. – Fan Duct and Unloading Auger Tunnel Installation on page 21 and Section 5.5. – Fan Transition Installation on page 23
Updated the reference part number for the Full Floor Aeration System assembly manual.	Section 5.7. – Layout and Positioning of Floor Supports on page 25 and Section 5.9. – Floor Plank to Support Assembly on page 26
Updated illustration for duct support location to show the new floor support components.	Section 5.8. – Duct Plank Support Layout on page 25
New table for “S” spacing and quantity of floor supports and A-Braces.	Section 6.1. – CIRC-AIR Cross Reference to Full Floor Layouts on page 28

CONTENTS

1. Introduction	4
2. Safety.....	5
2.1. Safety Alert Symbol and Signal Words.....	5
2.2. General Product Safety	5
2.3. Personal Protective Equipment.....	5
2.4. Safety Decals	6
2.5. Decal Installation/Replacement	6
2.6. Safety Decal Locations and Details	7
3. Before You Begin	10
3.1. Bin Design and Capacity	10
3.2. Foundation Design and Loads	10
3.3. Site and Assembly	10
3.4. Methods of Installation	11
3.5. Critical Assembly Requirements	11
3.6. Product Storage.....	12
3.7. Grain Bin Use	13
3.8. Important Notes	13
4. Preparation	15
4.1. Check Shipment.....	15
4.2. List of Tools and Equipment.....	15
4.3. Order Optional Equipment.....	16
5. Assembly	17
5.1. Assembly Safety	17
5.2. Foundation Planning and Specification	17
5.2.1 Important Foundation Planning Notes	17
5.3. Round Pit Assembly.....	19
5.4. Fan Duct and Unloading Auger Tunnel Installation	21
5.5. Fan Transition Installation.....	23
5.6. Round Pit Concrete Pouring Procedure	24
5.7. Layout and Positioning of Floor Supports.....	25
5.8. Duct Plank Support Layout.....	25
5.9. Floor Plank to Support Assembly	26
5.10. Flashing Installation.....	26
6. Appendix	28
6.1. CIRC-AIR Cross Reference to Full Floor Layouts	28
6.2. Approximate Concrete Requirements	32
6.3. Material List.....	33
6.4. Pit Kit Contents.....	34
6.5. Duct Kit Contents	34
6.6. Hardware Package Contents	34
7. Limited Warranty: Westeel Grain Bin Products	35

1. Introduction

This manual describes how to assemble a Westeel Circ-Air™ Round Pit Aeration System.

Before assembling the aeration system, please read this manual. Familiarize yourself with the process and the necessary precautions for efficient and safe assembly.

Everyone present at the assembly site is required to be familiar with all safety precautions.

Keep this manual available for frequent reference and review it with new personnel. Call your local distributor or dealer if you need assistance or additional information.





2. Safety

2.1. Safety Alert Symbol and Signal Words



This safety alert symbol indicates important safety messages in this manual. When you see this symbol, be alert to the possibility of injury or death, carefully read the message that follows, and inform others.

Signal Words: Note the use of the signal words **DANGER**, **WARNING**, **CAUTION**, and **NOTICE** with the safety messages. The appropriate signal word for each message has been selected using the definitions below as a guideline.

-  **DANGER** Indicates an imminently hazardous situation that, if not avoided, will result in serious injury or death.
-  **WARNING** Indicates a hazardous situation that, if not avoided, could result in serious injury or death.
-  **CAUTION** Indicates a hazardous situation that, if not avoided, may result in minor or moderate injury.
-  **NOTICE** Indicates a potentially hazardous situation that, if not avoided, may result in property damage.

2.2. General Product Safety

YOU are responsible for the **SAFE** use and maintenance of your aeration system. **YOU** must ensure that you and anyone else who is going to work around the aeration system understands all procedures and related **SAFETY** information contained in this manual.

Remember, **YOU** are the key to safety. Good safety practices not only protect you, but also the people around you. Make these practices a working part of your safety program. All accidents can be avoided.

- It is the aeration system owner, operator, and maintenance personnel's responsibility to read and understand **ALL** safety instructions, safety decals, and manuals and follow them when operating, or maintaining the equipment. 
- Owners must give instructions and review the information initially and annually with all personnel before allowing them to operate the aeration system. Untrained users/operators expose themselves and bystanders to possible serious injury or death.
- The aeration system is not intended to be used by children.
- Use the aeration system for its intended purposes only.
- Do not modify the aeration system in any way without written permission from the manufacturer. Unauthorized modification may impair the function and/or safety, and could affect the life of the aeration system. Any unauthorized modification will void the warranty.

2.3. Personal Protective Equipment

The following Personal Protective Equipment (PPE) should be worn when installing the equipment.

Safety Glasses

- Wear safety glasses at all times to protect eyes from debris.



Coveralls

- Wear coveralls to protect skin.



Hard Hat

- Wear a hard hat to help protect your head.



Steel-Toe Boots

- Wear steel-toe boots to protect feet from falling debris.



Work Gloves

- Wear work gloves to protect your hands from sharp and rough edges.



2.4. Safety Decals

- Keep safety decals clean and legible at all times.
- Replace safety decals that are missing or have become illegible. See decal location figures that follow.
- Replaced parts must display the same decal(s) as the original part.
- Replacement safety decals are available **free of charge** from your distributor, dealer, or factory as applicable.

2.5. Decal Installation/Replacement

1. Decal area must be clean and dry, with a temperature above 50°F (10°C).
2. Decide on the exact position before you remove the backing paper.
3. Align the decal over the specified area and carefully press the small portion with the exposed sticky backing in place.
4. Slowly peel back the remaining paper and carefully smooth the remaining portion of the decal in place.
5. Small air pockets can be pierced with a pin and smoothed out using the sign backing paper.

2.6. Safety Decal Locations and Details

Replicas of the safety decals that are attached to the aeration system and their messages are shown in the figure(s) that follow. Safe operation and use of the aeration system requires that you familiarize yourself with the various safety decals and the areas or particular functions that the decals apply to, as well as the safety precautions that must be taken to avoid serious injury, death, or damage.

Figure 1. Safety Decals

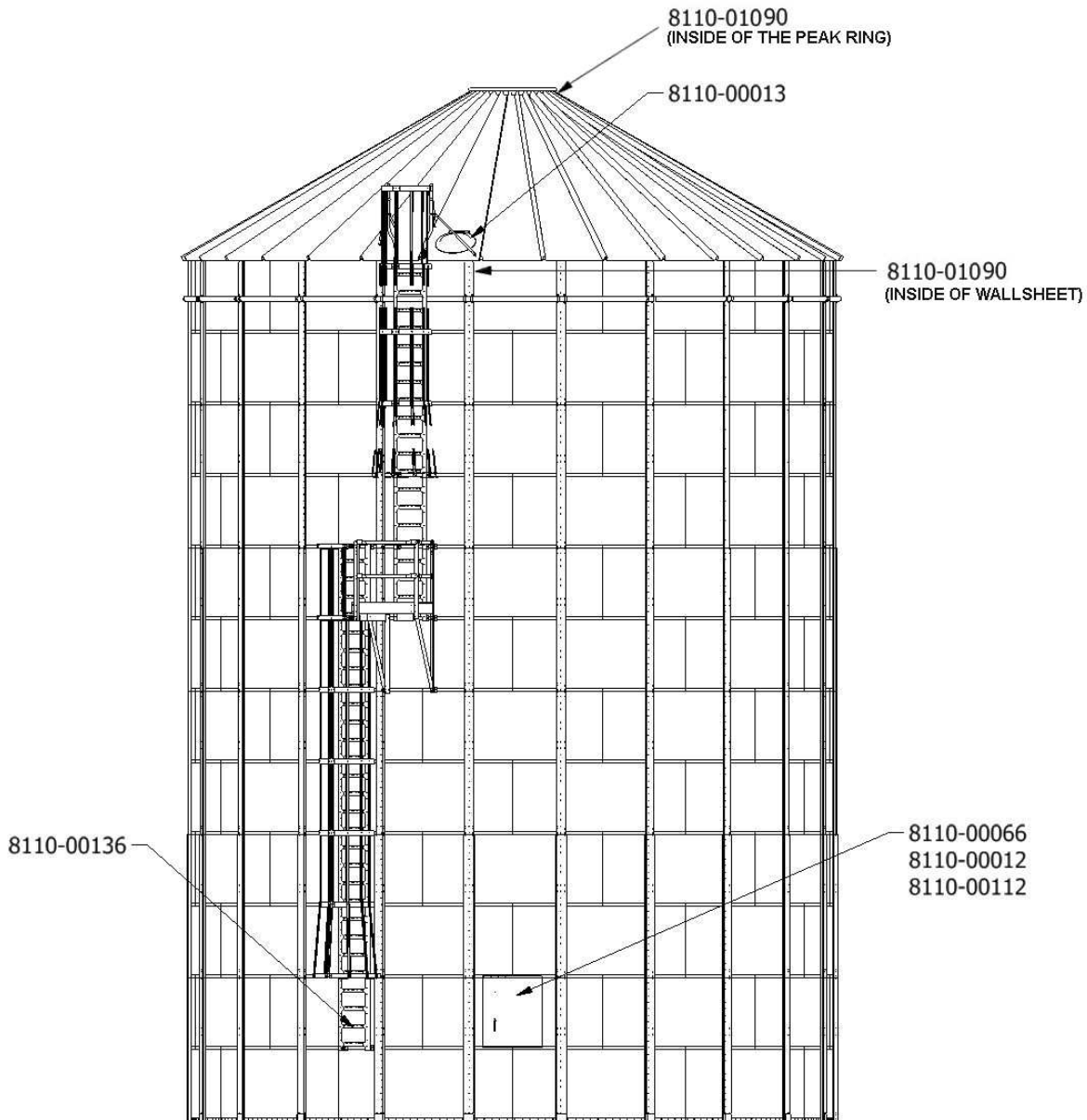





 WARNING	
	
SAFETY INSTRUCTIONS	
<ul style="list-style-type: none"> • Read operator’s manual and all safety decals before assembling, using, or servicing bin. • Close/latch all access doors when not in use. • Do not alter or modify bin structure. • Replace any damaged components only with factory made components. • This bin should only be used to store free flowing, granular material, unless specifically designed and marked otherwise. • When filling, use top filler cap and direct material to center of bin. • Do not over-fill bin. Material should not be in contact with or place pressure on roof sheets. 	

Part Number: 8110–00012

 WARNING	
	
ENTRAPMENT HAZARD	
<p>Never enter the bin when loading or unloading grain.</p> <p>If you must enter the bin:</p> <ol style="list-style-type: none"> 1. Shut off and lock out all power. 2. Use a lifeline, safety harness, and have an observer outside before entering the bin. 3. Wear proper breathing equipment or a respirator. 4. Avoid the center of the bin. <p>Failure to heed these warnings could result in serious injury or death.</p>	

Part Number: 8110–00013

 WARNING		
		
Rotating flighting could kill or dismember.	Flowing material could trap and suffocate.	Crusted material could collapse and suffocate.
Keep clear of all augers. DO NOT ENTER this bin!		
<p>If you must enter the bin:</p> <ol style="list-style-type: none"> 1. Shut off and lock out all power. 2. Use a safety harness and safety line. 3. Station another person outside the bin. 4. Avoid the center of the bin. 5. Wear proper breathing equipment or respirator. <p>Failure to heed these warnings could result in serious injury or death.</p>		

Part Number: 8110–00112

WARNING



FALLING HAZARD

To prevent serious injury or death:

- Do not climb ladder if damaged, wet, icy, greasy, or slippery.
- Maintain good balance by having at least three points of contact at all times.

Part Number: 8110-00136

NOTICE

When equipped with aeration system, to prevent roof and/or bin damage:

- Consult dealer to install adequate roof venting.
- Ensure all roof vents are open and unobstructed.
- Discontinue use of aeration fan if roof vents become obstructed with ice.

Part Number: 8110-00066



**FALL RESTRAINT
ANCHOR POINT
MAX WORKING LOAD:
1,000 lb [453 kg]**

SEE MANUFACTURER ROOF MANUAL FOR
DETAILED INSTRUCTIONS REGARDING
ANCHOR POINT LOCATIONS

Part Number: 8110-01090



3. Before You Begin

3.1. Bin Design and Capacity

These Westeel Grain Bins are designed for:

1. Non-corrosive free-flowing materials up to 55 lbs/ft³ (880 kg/m³) average compacted bulk density.
2. Maximum horizontal gusted wind speed of 94 mph (151 km/h)
3. Seismic zone 2a (U.B.C. 1997).
4. Roof Loading

Snow Load		Peak Load			
		15' – 24' bins		27' – 48' bins	
Imperial	Metric	Imperial	Metric	Imperial	Metric
15.0 lbs/ft ²	.72 kPa	4000 lbs.	17.8 kN	5000 lbs.	22.2 kN
24.0 lbs/ft ² (when optional roof stiffening rings installed)	1.15 kPa (when optional roof stiffening rings installed)				

3.2. Foundation Design and Loads

The foundations for the stiffened bin models are based on 4000 lbs. per sq. ft. (192 kPa) soil bearing capacity. All foundation designs use 3000 lbs. per sq. in. (21 MPa) ultimate compressive strength (after 28 days) for concrete and 43,500 lbs. per sq. in. (300 MPa) re-bar. The foundation designs included in this manual are suggestions only, and will vary according to local soil conditions. Westeel will not assume any liability for results arising from their use.

Important

Foundation should be uniform and level. Level should not vary by more than ¼" over a span of four feet under the bottom ring angle. Any variance from level must be shimmed under upright base assembly. If being utilized to support a full floor aeration system, this levelness requirement should extend across the complete floor area.

3.3. Site and Assembly

Unless otherwise specifically provided in writing, Westeel does not take responsibility for any defects or damages to any property, or injury to any persons, arising from or related to any site or assembly considerations, including but not limited to:

- Bin location and bin siting
- Soil conditions and corresponding foundation requirements (note that the examples provided in manuals are for specifically stated soil conditions)
- Bin assembly (Westeel recommends the use of qualified bin installers; contact Westeel for information on installers in your area)
- Field modifications or equipment additions that affect the bin structure
- Interconnections with neighboring structures

- Compliance with all applicable safety standards, including but not limited to fall restraint systems (ladders or other systems). Local safety authorities should be contacted as standards vary between jurisdictions.

3.4. Methods of Installation

The recommendations for assembling and installing Westeel grain bins must be closely followed to achieve the full strength of the bin and to achieve adequate weather sealing. The product warranty is void if:

1. Wall sheets and/or uprights not specified for a given tier are used.
2. Foundations are found to be inadequate or out-of-level.
3. Anchor bolts (cast-in-place, drill-in, chemical type or other) are found to be inadequate.
4. Off-center loading or unloading is used. (This does not apply to the use of approved side unloading systems.)
5. Materials stored are not free-flowing or have a compacted bulk density greater than 55 lbs/ft³ (880 kg/m³).

If using bin jacks during assembly, always lift on an upright. Choose a hoist with a adequate capacity for the expected empty bin deadload. Make sure the rated capacity of the hoist is not exceeded.

3.5. Critical Assembly Requirements

To ensure a successful, safe and reliable outcome you must comply with the following assembly techniques and practices:

1. Comply with all local code and jurisdictional requirements applicable to your aeration system installation.
2. Design and build foundations with the necessary strength for the loads they must support, and for local soil conditions. Westeel foundation guidelines are based on specific stated conditions and may not be applicable to local conditions.
3. Your foundation must provide uniform and level support to the structure being supported. Surface imperfections causing gapping must be remedied. This may involve, but not be limited to a) grouting under the bottom ring of a non-stiffened bin or tank, and b) shimming under the uprights of a stiffened bin or tank, or under the legs of a hopper.
4. Make sure that the proper hardware is utilized for all bolted connections. If a shortage occurs, do not substitute. Take the necessary steps to obtain the proper hardware. Make sure nuts are tightened to the required torque values as specified in the appropriate assembly manual.
5. Comply with all assembly instructions provided in the appropriate assembly manual to make sure your whole aeration system is constructed safely. **Important: Do not deviate from the wall sheet and upright layouts provided.**
6. Before anchoring your structure to its foundation, make sure the structure is round. The maximum variation from perfect roundness is 3/4" on the radius. Locate anchor bolts toward the outside of the anchor bolt holes (away from the circle) to permit the incremental expansion that can occur with the initial filling.
7. When installing roof stiffening rings, if it is necessary to shorten the stiffening ring tubes, shorten them as little as possible. Initially the nuts on the expanders should be centered and as close together as possible. When tightening, share the amount of take-up between expanders such that the nuts remain centered, and the amount of engagement between all expanders on the same ring is equalized.
8. If extending an existing bin or tank, ensure that the foundation is adequate for the increased loads it must support.



9. If installing an existing bin on a hopper, make sure the bin is designed for a hopper application, and that the foundation is capable of withstanding the substantial point loads that the hopper legs apply. If uprights are present, make sure that they are supported.
10. Make sure that an integral end-to-end connection exists between all mating uprights. Successive uprights must not overlap.
11. Vertical tolerances between uprights and wall sheets are tight. This can be affected by “jacking” techniques, which can allow the tolerance to grow or shrink depending on the technique used. The gapping between successive uprights must be monitored to ensure that upright holes align with wall sheet holes.
12. If catwalks are being installed on the structure, upright catwalk upgrades are likely required. The upgraded stiffeners must be installed in the correct locations to support the intended catwalk loads. Also, the structure must be properly oriented to ensure the eventual correct alignment between the catwalks and the supporting uprights. Finally, the connectors that tie into the uprights and support the catwalks are best installed during assembly of the structure. See the catwalk assembly manual for additional details.

3.6. Product Storage

Rust on Galvanized Parts

1. White rust forms when moisture is allowed to collect on galvanized surfaces that have yet to develop the durable zinc oxide layer. This zinc oxide layer naturally occurs as the surface interacts with carbon dioxide, and is characterized over time by the dull grey appearance that weathered galvanized surfaces get.
2. Parts that are not well ventilated or well drained can collect water between surfaces and develop white rust.
3. White rust is not a structural concern if its development is stopped in the early stages. A light film or powdery residue can occur after a period of heavy rainfall or a short time of improper storage. If white rust has started to develop, separate parts and wipe off any moisture. Next, using a clean cloth, apply a thin layer of petroleum jelly or food-grade oil to the entire part.
4. If moisture is left on parts, this white rust can become more aggressive and turn into red rust. Red rust can cause degradation in the material and become a structural concern. Any parts that have red rust should be replaced immediately.

Storage Guidelines

- Keep all bundles dry before assembly of the bin.
- Start assembly as soon as possible.
- Do not lay bundles on the bare ground. Raise all bundles 6" to 8" off the ground on wood blocks or timbers. (See Detail A in [Figure 2 on page 13.](#))
- Store curved wall sheets ‘hump-up’. (See Detail A in [Figure 2 on page 13.](#))
- All other bundles material should be placed so that they are well sloped to promote good drainage. (See Detail B in [Figure 2 on page 13.](#))
- Roof sheets must be elevated at least 12" at the small end of the sheets. (See Detail B in [Figure 2 on page 13.](#))
- Temporary storage can be provided by erecting a simple framework supporting a waterproof tarp. (See Detail C in [Figure 2 on page 13.](#))
- All bin boxes, ladder boxes and hardware boxes should be stored inside. These are not waterproof, and will deteriorate in normal weather conditions, allowing moisture to contact the parts inside.

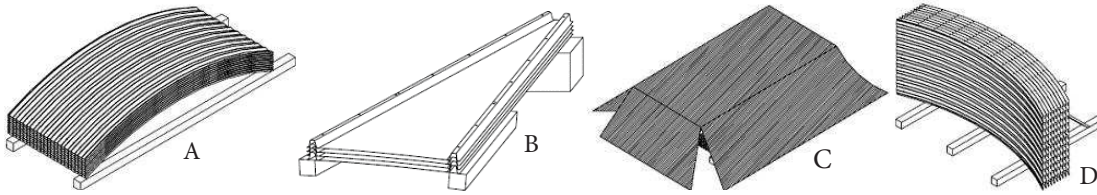
Figure 2. Product Storage**If Parts Become Wet**

1. If parts become submerged or wet, the bundles should be opened as soon as possible, sheets or material separated and dried. Keep separated until assembly.

Brace parts properly so as to avoid damage or injury from material falling when in storage. (See Detail D in [Figure 2 on page 13.](#))

2. Any boxed parts that become wet should be dried and stored in a new box that is free of moisture.
3. In addition to wiping down wall sheets, a food-grade oil can also be applied with a clean, lint-free cloth. This will assist in preventing any further moisture from contacting the galvanizing on the steel. Due to safety concerns with installation and use, Westeel does not recommend the use of oil on other parts such as roof sheets and safety ladders.

3.7. Grain Bin Use

- Do not off-center unload a grain bin. It is imperative to unload from the center of the bin first, until as much grain as possible has been removed, and only then proceed to unload from the next closest unload gate to the center. Continue utilizing the unload gates in succession from the center towards the outside. Gate control mechanisms should be clearly marked and interconnected to prevent an external gate from being opened first.
- The only exception to center unloading is when a properly designed and installed side draw system is utilized. However, as bins tend to go out of round when employing side draws, the bin must be completely emptied before refilling.
- When unloading a bin with a mobile auger through a properly designed auger chute, the entry end of the auger should be pushed into the center of the bin before the auger is engaged. Slower rates of flow are preferable and should not exceed the capacity of an 8" auger.
- Ensure that the inner door panels of grain bin doors are completely closed and latched before filling the grain bin.
- Never enter a loaded grain bin for any reason. Grain can be a killer.

3.8. Important Notes

- Westeel does not provide a foundation design for this product, and is not liable for any damages or injuries related to inadequately designed or constructed foundations. Customers must contract professional services for all foundation design and construction work. For information on foundation design requirements, refer to [Section 3.2. – Foundation Design and Loads on page 10.](#)
- In order to maintain your wall sheets in good condition separate sheets and allow air circulation between them. Store sheets in a dry place. Do not store sheets with sheet ends pointing upwards.
- To keep an even pressure on walls, the bin must always be unloaded from the centre.



- Contact local power officials for minimum power line clearance.
- See [Section 3.5. – Critical Assembly Requirements on page 11](#) for mandatory siting and assembly requirements.
- Store only non-corrosive, free-flowing materials up to 55 lbs/ft³ (800 kg/m³) average compacted density in Westeel bins.
- Tighten all bolts to the recommended torque settings.
- Do not locate grain bins close to high buildings, which might cause snow to fall onto or build up on the roof of the grain bin. Consider future expansion and allow space for loading and unloading of the bin. Your dealer and local government agricultural consultants can help you plan your storage system for maximum efficiency.
- Read [Section 3.2. – Foundation Design and Loads on page 10](#) *before* beginning your installation.
- Make sure the pit is "circular" by measuring the inside diameter at several points. A 1" variation will not adversely affect installation of the floor. Greater variation may require field cutting of some planks.
- Mark the exact centre of the bin to aid in properly locating the round pit wall location.
- See [Section 3.1. – Bin Design and Capacity on page 10](#) for information about materials that can be stored.
- Operating drying fans when the bin is empty or near empty may cause movement of floor supports and/or floor planks, resulting in a weak or unstable floor structure. To test the fan when the bin is empty, cover the fan inlet to block airflow and operate for a period of less than one minute only.
- A smooth, flat and level concrete floor is **critical** to a successful installation. A maximum flatness variation of 1/4" over 4 ft is allowable. Pit depth from bin floor to pit floor is critical to correct fit and avoidance of future damage.
- This manual is to be read with the bin manual, and/or the WC Sealform manual (if used).

4. Preparation

4.1. Check Shipment

Unload the parts at the assembly site and compare the packing slip to the shipment. Ensure that all items have arrived and that none are damaged.

Report damaged parts or shortages immediately to the delivering carrier, followed by a confirming letter requesting inspection by the carrier, if required. Order any replacement parts immediately to ensure that assembly will not be held up by missing parts. All parts will be charged for and credit will be issued by party at fault. No credit will be issued if freight bills are signed as received in good condition.

4.2. List of Tools and Equipment

Use correct, quality tools and equipment. These should include:

Tools

- Pliers
- 3/8 inch portable drill and drill bits
- 3/8' drive socket wrench
- Sockets (multiple 9/16" and 1/2" sockets recommended)
- Screw driver
- 28 oz. framing hammer
- Wood saw
- 9/16" box-end wrench
- Metal-cutting saw or cutting torch
- 4 ft. level
- 25 ft. tape measure
- Flat spade shovel

Minimum Recommended Safety Equipment

- A properly-stocked first-aid kit
- Eye, foot, head, and hand protection (safety glasses, steel-toed boots, hard hat, work gloves)
- Cable, chain, or rope to tie-off bin or jacks in case of wind
- Body harness and lifeline (for use where falling hazard exists)
- Ground fault interrupt protected electrical hook-ups



4.3. Order Optional Equipment

Optional equipment such as unloading augers, aeration equipment, anchor bolts, foundation sealant, external ladders, safety cage and platforms, etc., should all be on site and checked before assembly starts. Plan your installation in advance. For details, see assembly instruction supplied with optional equipment.

5. Assembly



Before continuing, ensure you have completely read and understood this manual's Safety section, in addition to the safety information in the section(s) below.

5.1. Assembly Safety

WARNING

- Do not take chances with safety. The components can be large, heavy, and hard to handle. Always use the proper tools, rated lifting equipment, and lifting points for the job.
- Carry out assembly in a large open area with a level surface.
- Always have two or more people assembling the aeration system.
- Make sure you have sufficient lighting for the work area.
- Tighten all fasteners according to their specifications. Do not replace or substitute bolts, nuts, or other hardware that is of lesser quality than the hardware supplied by the manufacturer.
- Stay away from overhead power lines and other obstructions during assembly. Contact with power lines can cause electrocution.
- Do not work in high winds.

5.2. Foundation Planning and Specification

There are several foundation and CIRC-AIR combinations available to accommodate your specific bin requirements. Basic bin foundation dimensions can be found in the Bin Installation and Storage Instructions or Seal Form Installation and Storage Instructions.

Make sure that you have all instruction manuals and materials to complete the project before beginning your foundation.

5.2.1 Important Foundation Planning Notes

1. Choose a site that is well drained and has a minimum soil-bearing capacity of 3700 lbs. per sq. ft. (177kPa). If soil bearing capacity is not known, consult a local engineering consultant.
2. Use a minimum of 4" to 6" (100-150 mm) of well compacted coarse gravel below pit floor and bin ring footing.
3. Determine and mark the location of the exact centre of bin (point A).
4. Determine where the fan transition will exit the bin (point B).
5. Refer to the bin manual and/or the WC Seal Form manual for outer ring (curb) foundation details. From this determine the finished height of your bin floor for future reference.
6. Use 3000 psi (20MPa) concrete, and 43,500 psi (300 MPa) re-bar.
7. Make sure the foundation is level, and that pit depth is correct or damage will occur to aeration planks.



Figure 3. Locations of System Parts on the Foundation

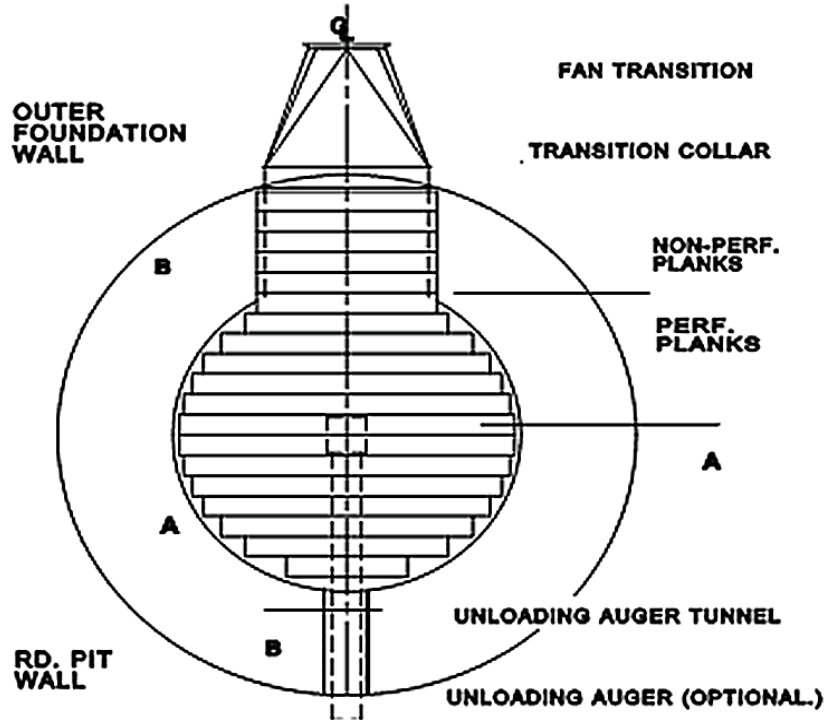

Note

- For maximum grain drying efficiency the optional unload auger discharge should be located directly across from the fan.
- The unload auger (if used) must be installed using a formed tunnel as shown using wood forms and planks. The tunnel may be formed with the same duct wall as the transition but must be specified when ordering the CIRC-AIR system.
- Ensure the transition placement leaves adequate room for fan installation.

Figure 4. Foundation Plan View and Sectional

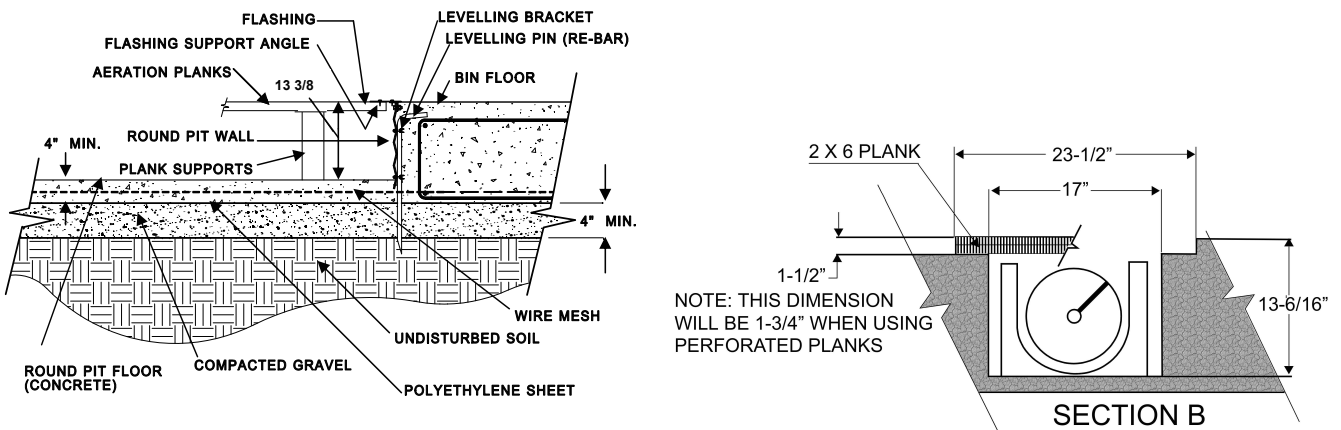

5.3. Round Pit Assembly

1. Remove top soil as specified in the Bin and/or Seal Form manuals and replace with compacted gravel as shown in [Figure 6 on page 21](#).
2. Check the bin manual and/or seal form manual for further foundation details that apply to your installation.
3. Fabricate a screeder board (2x4 or 2x6) to the dimension A shown in [Figure 5 on page 19](#) and [Table 1 on page 20](#).
 - a. For best results, make sure the screeder board is 6" longer than the pit diameter and straight (1/8" variance in 10').
 - b. If necessary to reduce flex, strengthen the screeder by applying 1 x 4 board (over 75% of the length of the screeder).
4. Fasten the center pivot and scribe to the screeder as shown in [Figure 5 on page 19](#) (Stage 1).
 - a. Use a metal rod (re-bar) for a scribe.
 - b. Secure the rod to the board with a levelling bracket (found in the Hardware Pail).
 - c. Drive a 24" piece of 10M or #4 re-bar into the ground where center point of bin will be.
 - d. Rotate the screeder bar around the center point, using the scribe to mark a circle.

This will provide a reference line to guide pit form and flashing support angle assembly.
5. Remove the scribe from the screeder and cut the screeder board to dimension B in [Table 1 on page 20](#).
6. Fasten the depth control bar as shown in [Figure 5 on page 19](#) (Stage 2), ensuring depth control bar is fastened square to the screeder board.

Figure 5. Screeder Assembly Detail

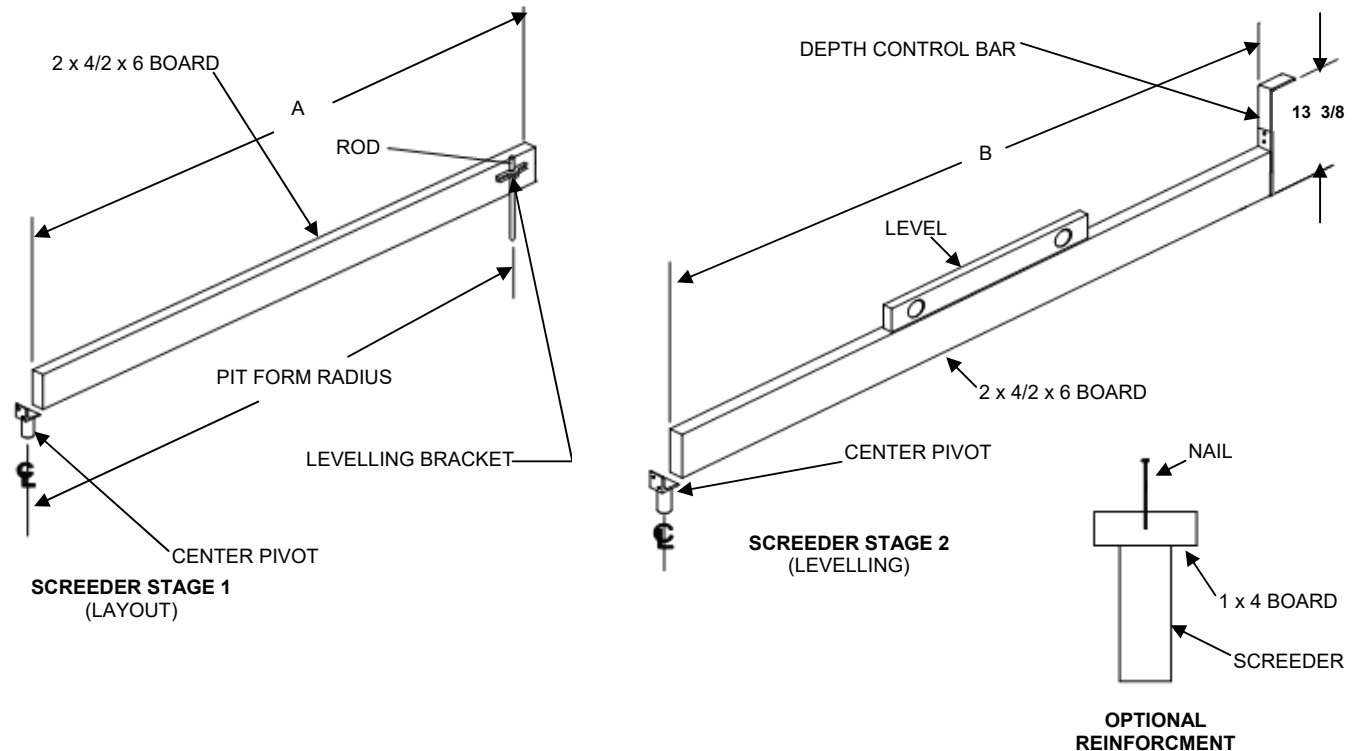
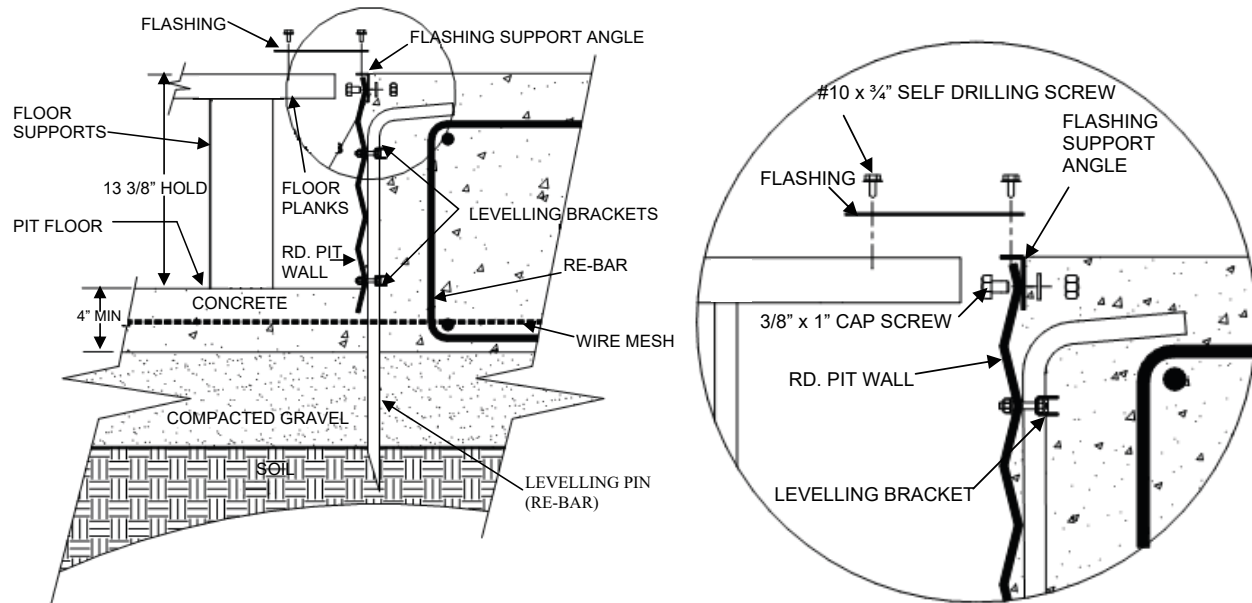

Table 1. Screeder Dimensions

Round Pit Size	12'	15'	18'	21'	24'	27'	30'	33'	36'	42'	
Screeder Size	2 x 4	2 x 4	2 x 4	2 x 4	2 x 6	2 x 6	2 x 6	2 x 6	2 x 6	2 x 6	
Dim	"A"	76	95	114	131	149	167	185	203	221	257
	"B"	70 1/2	88 1/2	106	124	142	160	178	196 1/2	213 1/2	249

7. Assemble the CIRC-AIR wall sheets and the flashing support angle.
 - a. See [Figure 6 on page 21](#) for assembly details.
 - b. Ensure that the flashing support angle seam falls in the middle of a wall sheet. The flashing support angle is supplied in straight lengths and is bent to suit the curve of the pit wall during installation.
 - c. *Note that the top leg of the flashing support angle faces inside.*
 - d. Do not tighten the bolts at this time.
8. Position the pit wall so that the screeder can rotate freely around the entire pit wall.
 - a. Check the pit wall for roundness and adjust if required.
 - b. Install leveling brackets on the pit wall sheets.
9. Drive a 28" piece of re-bar through the leveling brackets as shown in [Figure 6 on page 21](#) to use as a leveling pin.
 - a. Ensure that there is enough travel for the top leveling bracket to move a maximum of 4".
 - b. Make sure that the re-bar is firmly anchored in the ground, but can slide freely on the form sheet.
10. Lift the pit wall to where the flashing support angle is level with the pre-determined bin floor level.
 - a. Tighten the leveling brackets to hold the pit wall in place. Refer to the bin manual and/or seal form manual for pre-determined bin floor level.
 - b. See [Section 5.2.1 – Important Foundation Planning Notes on page 17](#)
11. Adjust the center pivot pin so that the screeder is level with the depth control bar resting on the flashing support angle.
 - a. Using the screeder, level the pit wall at approximately the quadrant points around the circumference of the pit wall.
 - b. If necessary, readjust.
 - c. Lock the pit wall in place by tightening the leveling brackets.
 - d. Repeat the leveling procedure at the remaining bracket positions.
 - e. Extra care must be taken to ensure that the top of the pit wall is level. This will ensure the screeder will produce a level pit floor.
 - f. Tighten all bolts and recheck that the pit wall has remained level and that parts are installed correctly.
12. Once the form is levelled, shim the pit wall with stones or concrete to hold level. Check that the outside form is secure and installed correctly.
13. Install the fan transition and duct wall forms as per instructions in [Section 5.4. – Fan Duct and Unloading Auger Tunnel Installation on page 21](#).

(Also see [Section 5.2.1 – Important Foundation Planning Notes on page 17](#).)

Figure 6. CIRC-AIR Assembly Detail**Important**

Pit floor must be level to prevent damage to aeration planks and plank supports.

5.4. Fan Duct and Unloading Auger Tunnel Installation

There are several types of foundations a CIRC-AIR system can be applied to. Determine the foundation type that applies to your installation, and follow that application's instructions. Refer to all manuals; Bin, Sealform, and CIRC-AIR.

1. After the CIRC-AIR wall sheet and outside concrete form are complete:
 - a. Lay out the location of the aeration fan transition and optional unloading auger tunnel (if used).
 - b. **Note that the fan transition can only be located between leveling pins and between bin uprights.**
2. Cut openings in the outside concrete form.
 - a. Make sure the transition bottom is level with the pit floor.
 - b. **The round pit wall opening is cut after the concrete is cured.**
 - c. Make sure the pit wall is trimmed down to the pit floor.
 - d. The opening for unloading can be up to 17" wide.
 - e. The auger tunnel can use the same wall form kit as the fan duct (not included).
 - f. When using non-perforated planks for the unload auger tunnel, the planks must be trimmed to fit the smaller opening span.
 - g. The unloading auger tunnel can also be fabricated from wood and covered with pressure treated 2 x 6 boards. See [Section 5.2.1 – Important Foundation Planning Notes on page 17](#) for suggested construction.

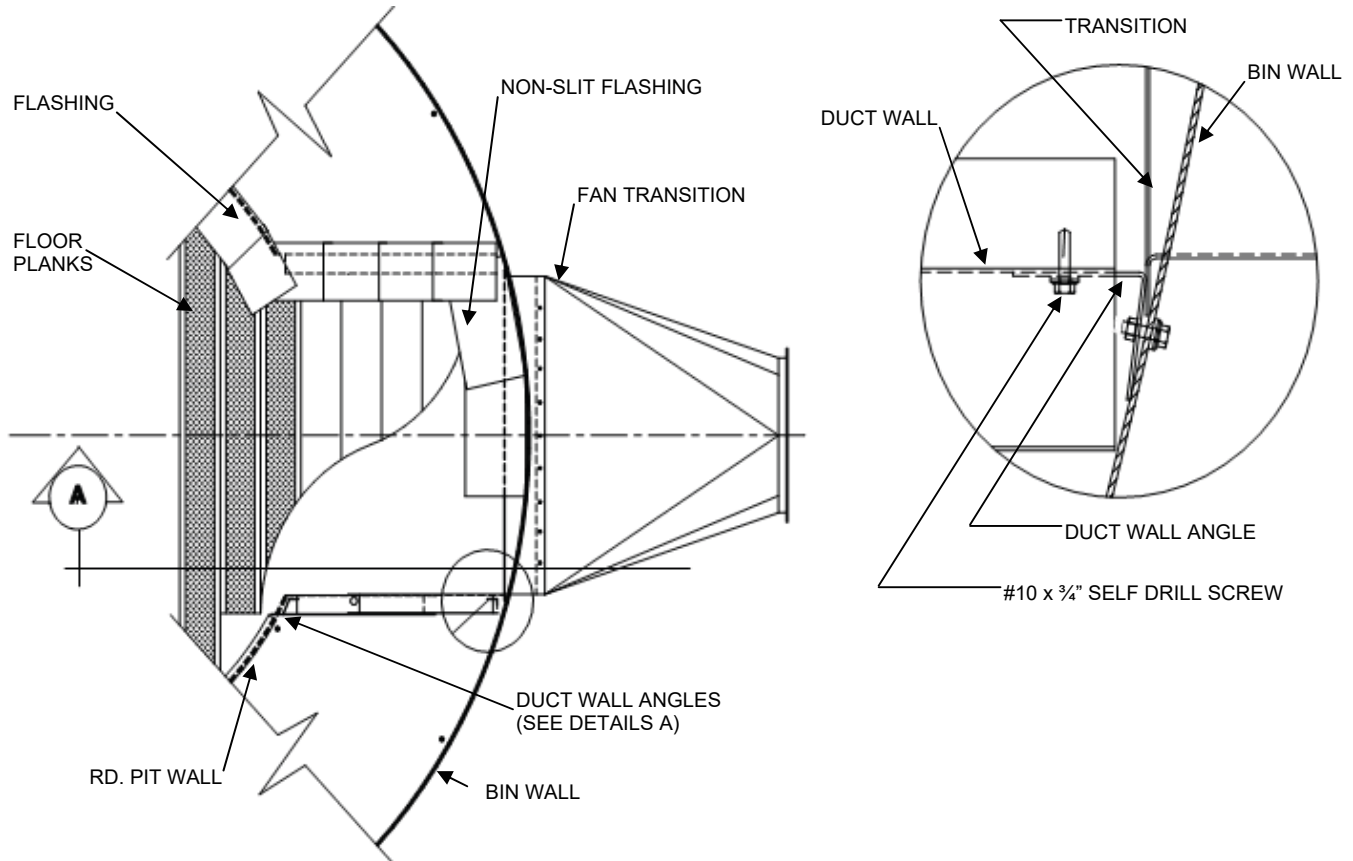
Figure 7. Duct Tunnel Detail

3. Fasten the duct wall forms to the pit wall and the outside form with angle brackets.
 - a. Duct angles may need to be bent slightly for best fit.
 - b. There may be one or more sets of duct panels depending on the bin and round pit combination.
 - c. Refer to [Section 6.3. – Material List on page 33](#).
 - d. When installing duct panels ensure all overlaps are in the direction of the air flow.
4. Fasten duct wall angles (2) to the round pit wall, in line with duct wall forms and transition walls.
 - a. Install leveling brackets.
 - b. Drive a 28" piece of re- bar through the leveling bracket.
 - c. Level top of the duct to the pre-determined bin floor height.
 - d. Fasten duct panels to the angles on the round pit walls.
 - e. Make sure the duct is secure by placing 2 x 4 boards between duct walls before pouring concrete.
 - f. For pouring procedure see [Section 5.6. – Round Pit Concrete Pouring Procedure on page 24](#).

Important

Fan transition must not be located under a bin upright (where applicable).

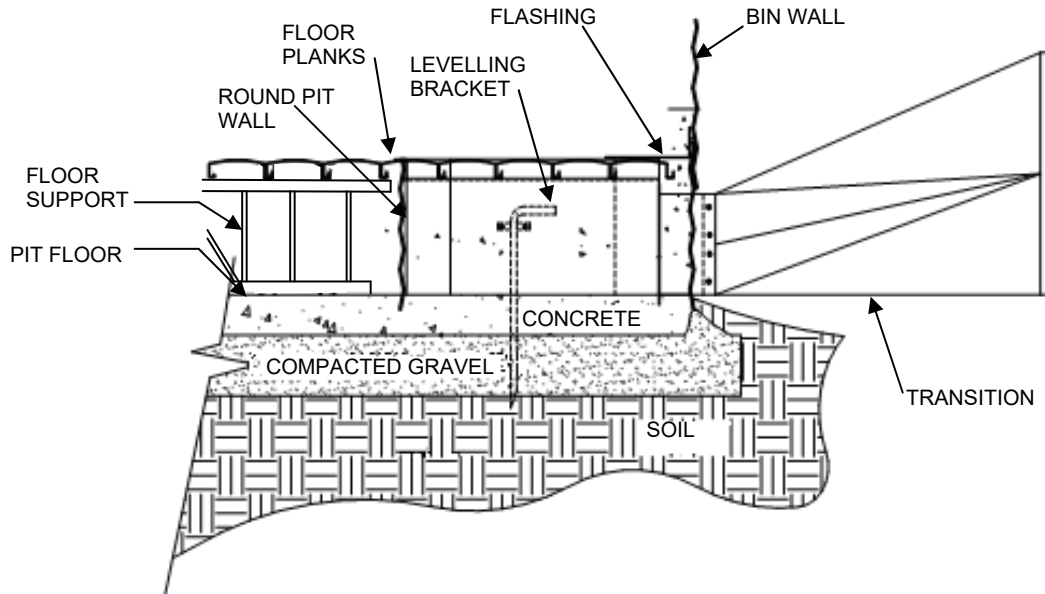
Figure 8. Section A

5.5. Fan Transition Installation

The fan transition is ordered separately according to your fan size and application. Ensure you have the correct size before beginning transition installation. Refer to all manuals (i.e. Bin and Sealform) for further instruction to your specific requirement.

1. At the fan's pre-determined location, mark a line level with the pit floor on the outside of the bin foundation form.
2. Place the fan transition so the bottom of the transition is flush with the pit floor line:
 - a. Cut out the hole in the wall sheet, allowing minimum clearance.
 - b. The unload auger hole is best located opposite the transition hole.

Important

Do not cut through vertical wall seams or stiffeners.

3. Insert the fan transition.
4. Secure the fan transition to the form.
 - a. In seal form applications, use shims (not supplied) between the wall sheet and the transition to ensure proper load transfer to the floor.
 - b. When using a curb type foundation, ensure there is concrete under the transition when pouring.
5. Seal the connection with caulking.



5.6. Round Pit Concrete Pouring Procedure

For concrete quantities, see [Section 6.2. – Approximate Concrete Requirements on page 32.](#)

1. Place the re-bar and wire mesh as per the foundation specifications shown in the Bin manual and/or Seal Form manual.
 - a. Support re-bars in numerous places with small stones or pieces of concrete, ensuring that there will be at least 2 inches of concrete under the bottom re-bars.
 - b. Bend levelling pins over as shown in [Figure 6 on page 21.](#)
 - c. Install snap ties between outer levelling pins and inner levelling pins (not supplied).
 - d. Support the outer form wall and inner form wall with temporary cross ties at the top of the form to ensure the form remains round as shown in [Figure 9 on page 24.](#)
2. Cut and install two 2 x 4 boards per wall sheet and place between outer form and inner form approximately at center elevation.
 - a. Pour concrete in stages working around the whole pit to ensure outer form and pit wall is not moved.
 - b. When concrete reaches the spacer boards remove these boards. Refer to [Figure 9 on page 24.](#)

Figure 9. Pit Wall Retainers

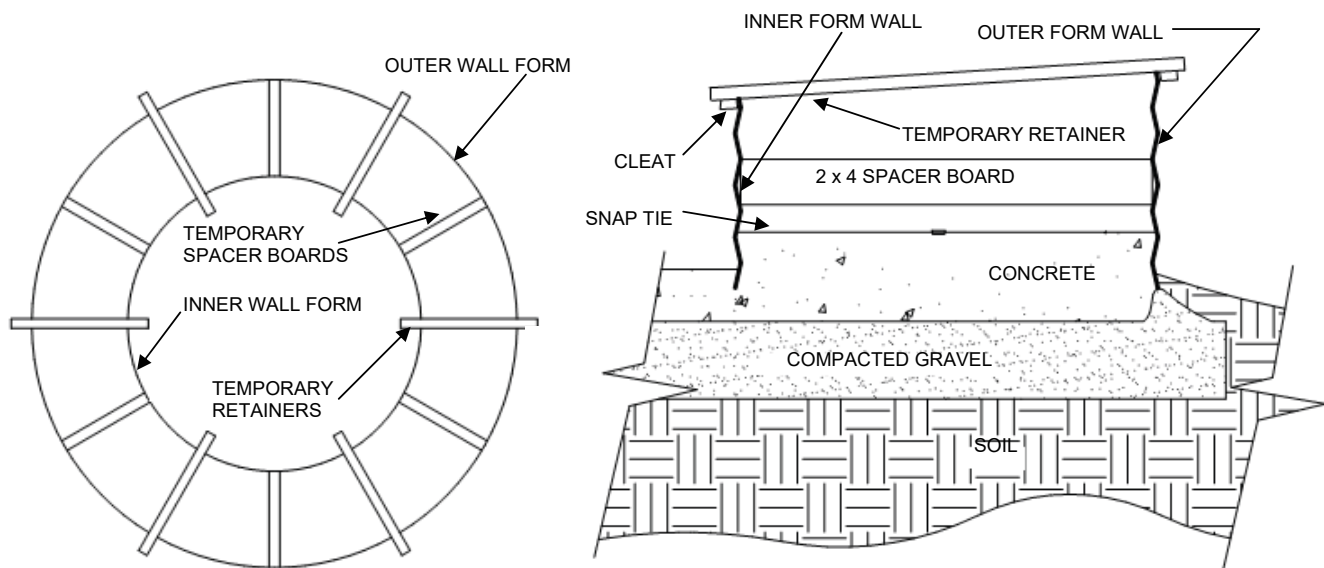

3. Allow the concrete to flow under the pit wall.
 - a. Make sure there is enough concrete to the screed floor level and that it is without voids.
 - b. Make sure there are no voids in bin foundation.
4. Level the pit floor concrete with the screeder, rotating around the center pivot pin.
 - a. Level the bin floor with the top of the flashing support angle and according to bin foundation specifications.
 - b. **Note:** Seal form and round pit screeder center pivot points are at different elevations. When both products are used together, use a shorter seal form screeder to run on the flashing support angle and the seal form thrust ring.
 - c. **When using a Seal Form Kit retighten nuts on all anchor bolts to 50 ft-lb torque after concrete has cured for 28 days.**

5. Allow the concrete to cure for at least three weeks (21 days) before proceeding with bin assembly.
6. Assemble the bin as per the bin installation manual.

Important

Do not fill up the bin before the concrete has fully cured for 28 days! Failure to follow these instructions may result in catastrophic bin failure.

5.7. Layout and Positioning of Floor Supports

Note

For floor support positioning information, see the Full Floor Installation Instructions in the Full Floor Aeration System manual, Part #198836.

5.8. Duct Plank Support Layout

1. Snap a chalkline on the fan duct tunnel floor, as shown in [Figure 10 on page 25](#), dividing the duct tunnel into three equal spaces
2. Place a support along the full length of each line and snap a non-perforated plank into the adjacent perforated plank.
3. Snap the next non-perforated plank into the first.
4. Repeat step 3 till the duct has completely covered the supports as shown below, working in the build direction as shown.

Note

When the first perforated plank of CIRC-AIR system is shorter than 55 inches, the perforated plank must be substituted with a non-perforated plank.

Figure 10. Duct Support Location

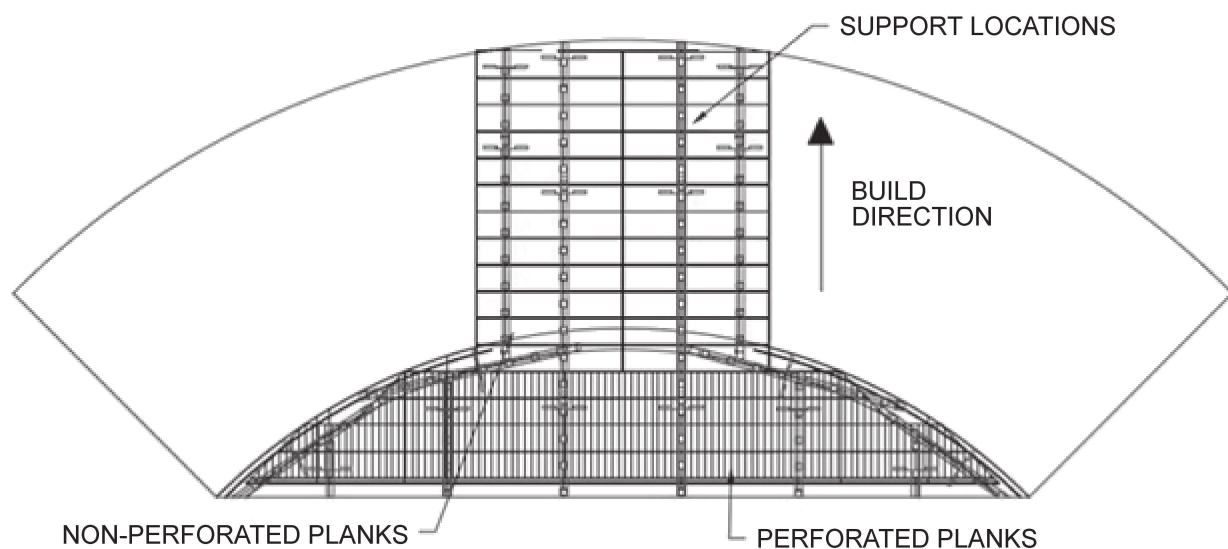

5.9. Floor Plank to Support Assembly

Note

For floor support assembly information, see the Full Floor Installation Instructions in the Full Floor Aeration System manual, Part #198836.

5.10. Flashing Installation

1. After all the floor planks have been installed, fasten flashing pieces to the flashing support angle.
2. Install the flashing so that the sweep screw rotation "steps up" onto the flashing as shown below.
3. Fasten the flashing to the floor plank and the flashing support angle with #10 x 3/4" self-drilling screws.
4. Drive the two screws (supplied with each flashing) through the flashing at each overlap area. (See [Figure 11 on page 27](#).)
5. Begin attaching flashing directly opposite the fan duct tunnel and fasten flashing in the direction the bin sweep will rotate.
6. Fasten all flashing to the angle support first, then fasten flashing to planks.
7. Make sure flashing panel corners overlap a maximum of 3/4" (see [Figure 11 on page 27](#)).
8. When fastening flashing over fan duct tunnel, lap the flashing 1" onto the concrete bin floor and secure the flashing to non-perforated planks in two places, as shown.
9. Fasten angled flashing to the bin wall using a 5/16" bolt, washer and nut at each corner.
10. The bin wall will require field drilling.
11. After bolting the flashing to the bin wall, fasten the flashing to the fan duct planks.

Figure 11. Flashing Installation

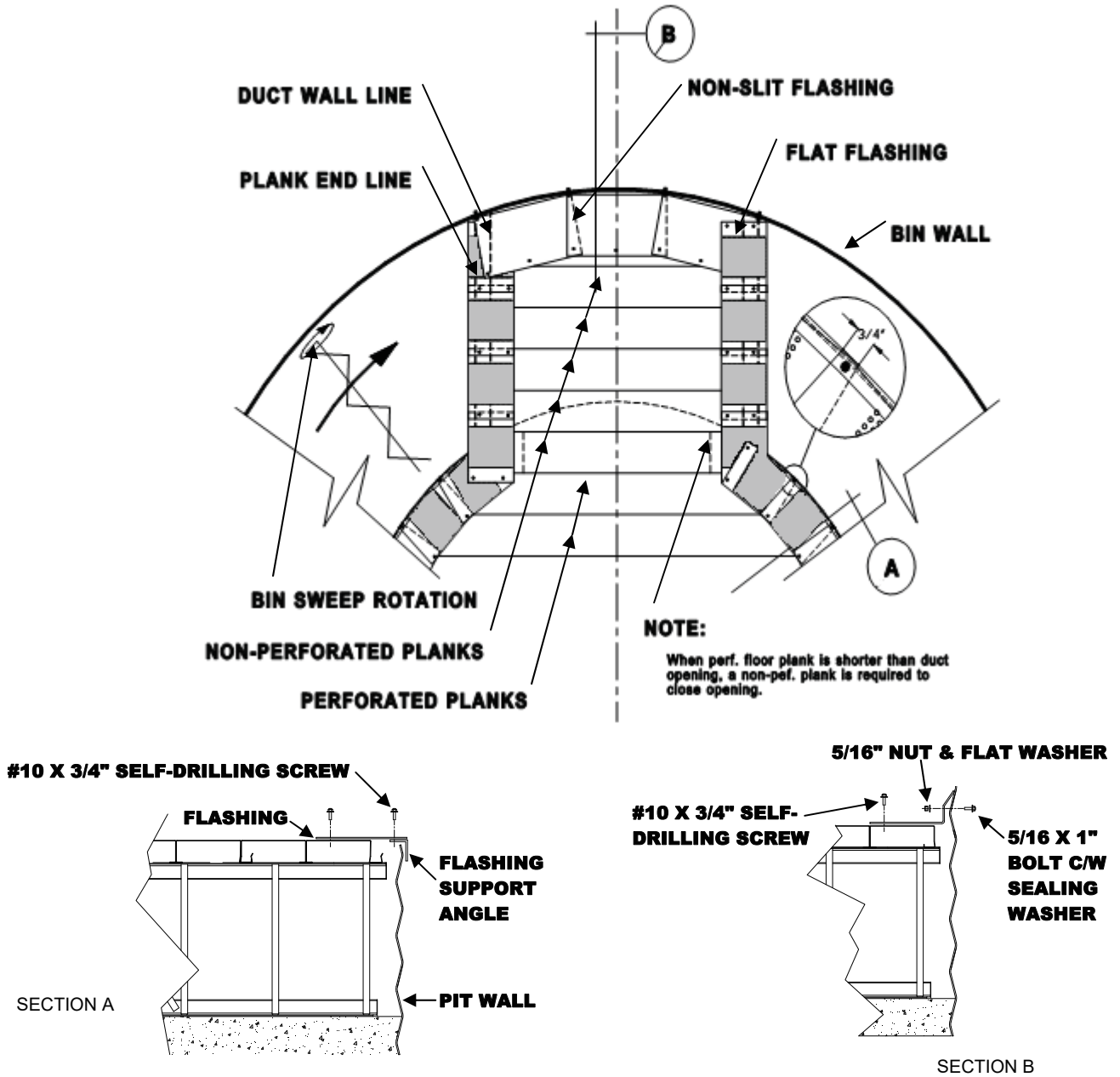

6. Appendix

6.1. CIRC-AIR Cross Reference to Full Floor Layouts

Table 2. Recommended “S” Spacing and Required Minimum Quantity of Floor Supports and A-Braces

Bin Model	Circ-Pit Dia. (ft)	”S” Spacing (in)	Floor Support (196605)	A-Brace (196606)	Bent A-Brace (196604)
1504-07	12	35	28	32	—
1508-09	12	34	28	32	—
1510	12	33	28	32	—
1511-12	12	32	28	32	—
1804-07	12	34	32	36	—
1804-07	15	34	38	44	—
1808	12	33	32	36	—
1808	15	33	40	46	—
1809	12	31	32	36	—
1809	15	31	40	46	—
1810	12	30	32	36	—
1810	15	30	42	48	—
1811	12	29	32	36	—
1811	15	29	42	48	—
1812	12	28	32	36	—
1812	15	28	42	48	—
194-7	12	33	36	40	—
194-7	15	33	44	50	—
198	12	31	36	40	—
198	15	31	44	50	—
2104-07	12	33	36	40	—
2104-07	15	33	44	50	—
2108	12	31	36	40	—
2108	15	31	44	50	—
2109	12	29	36	40	—
2109	15	29	46	52	—
2110	12	27	38	44	—
2110	15	27	46	52	—
2111	12	26	38	44	—
2111	15	26	46	52	—
2112	12	25	40	46	—
2112	15	25	46	52	—
2404-07	15	31	48	54	—
2404-07	18	31	54	60	—
2408	15	29	50	56	—
2408	18	29	58	66	—
2409	15	27	50	56	—
2409	18	27	60	68	—
2410	15	25	50	56	—
2410	18	25	62	70	—
2411	15	24	54	62	—

Table 2 Recommended “S” Spacing and Required Minimum Quantity of Floor Supports and A-Braces (continued)

Bin Model	Circ-Pit Dia. (ft)	”S” Spacing (in)	Floor Support (196605)	A-Brace (196606)	Bent A-Brace (196604)
2411	18	24	64	72	—
2412	15	23	56	64	—
2412	18	23	66	76	—
2704-07	15	30	54	60	—
2704-07	18	30	58	64	—
2704-07	21	30	72	80	—
2708	15	27	54	60	—
2708	18	27	64	72	—
2708	21	27	76	86	—
2709	15	25	54	60	—
2709	18	25	66	74	—
2709	21	25	82	92	—
2710	15	24	58	66	—
2710	18	24	68	76	—
2710	21	24	82	92	—
2711	15	23	60	68	—
2711	18	23	70	80	—
2711	21	23	84	94	—
2712	15	22	60	54	14
2712	18	22	72	68	14
2712	21	22	86	86	12
3004-07	18	28	66	74	—
3004-07	21	28	76	84	—
3008	21	26	84	94	—
3008	24	26	92	102	—
3009	18	24	72	80	—
3009	21	24	86	96	—
3009	24	24	100	112	—
3010	18	23	74	84	—
3010	21	23	88	98	—
3010	24	23	100	112	—
3011	18	22	76	70	16
3011	21	22	90	88	14
3011	24	22	102	100	14
3012	18	21	78	72	16
3012	21	21	92	90	14
3012	24	21	108	108	14
3304-07	18	27	72	80	—
3304-07	21	27	84	94	—
3304-07	24	27	96	106	—
3304-07	27	27	110	122	—
3308	18	25	74	82	—
3308	21	25	90	100	—
3308	24	25	102	114	—
3308	27	25	114	126	—
3309	18	23	78	88	—



Table 2 Recommended “S” Spacing and Required Minimum Quantity of Floor Supports and A-Braces (continued)

Bin Model	Circ-Pit Dia. (ft)	”S” Spacing (in)	Floor Support (196605)	A-Brace (196606)	Bent A-Brace (196604)
3309	21	23	92	102	—
3309	24	23	104	116	—
3309	27	23	122	136	—
3310	18	22	80	72	18
3310	21	22	94	90	16
3310	24	22	106	102	16
3310	27	22	130	130	14
3311	18	21	82	74	18
3311	21	21	96	92	16
3311	24	21	112	110	16
3311	27	21	132	134	14
3312	18	20	82	74	18
3312	21	20	100	96	16
3312	24	20	118	116	16
3312	27	20	140	142	14
3604-07	21	27	88	98	—
3604-07	24	27	100	110	—
3604-07	27	27	114	126	—
3604-07	30	27	132	146	—
3608	21	24	94	104	—
3608	24	24	108	120	—
3609	24	22	110	104	18
3609	27	22	134	132	16
3609	30	22	156	158	14
3610	21	21	100	94	18
3610	24	21	116	112	18
3610	27	21	136	136	16
3610	30	21	156	158	14
3611	21	20	104	98	18
3611	24	20	122	118	18
3611	27	20	144	144	16
3611	30	20	166	170	14
3612	21	19	108	102	18
3612	24	19	124	120	18
3612	27	19	146	146	16
3612	30	19	174	178	14
4204-07	24	24	116	128	—
4204-07	27	24	132	146	—
4204-07	30	24	150	164	—
4204-07	33	24	172	188	—
4204-07	36	24	200	218	—
4208	24	23	116	128	—
4208	27	23	134	148	—
4208	30	23	158	174	—
4208	33	23	178	194	—
4208	36	23	206	224	—

Table 2 Recommended “S” Spacing and Required Minimum Quantity of Floor Supports and A-Braces (continued)

Bin Model	Circ-Pit Dia. (ft)	”S” Spacing (in)	Floor Support (196605)	A-Brace (196606)	Bent A-Brace (196604)
4209	24	21	124	116	22
4209	27	21	144	140	20
4209	30	21	164	162	18
4209	33	21	188	188	18
4209	36	21	220	224	16
4210	24	20	130	122	22
4210	27	20	152	148	20
4210	30	20	174	174	18
4210	33	20	198	200	18
4210	36	20	228	234	16
4211	24	19	132	124	22
4211	27	19	154	150	20
4211	30	19	182	182	18
4211	33	19	208	210	18
4211	36	19	236	242	16
4212	24	18	136	130	22
4212	27	18	164	162	20
4212	30	18	190	192	18
4212	33	18	216	220	18
4804-07	36	24	208	226	—
4804-07	42	24	254	274	—
4808	30	22	172	166	22
4808	33	22	194	190	22
4808	36	22	218	218	20
4808	42	22	278	282	18
4809	30	20	182	178	22
4809	33	20	206	204	22
4809	36	20	236	238	20
4809	42	20	298	304	18
4810	30	19	190	186	22
4810	33	19	216	214	22
4810	36	19	244	246	20
4810	42	19	316	324	16
4811	30	18	198	196	22
4811	33	18	224	224	22
4811	36	18	260	264	20
4811	42	18	328	338	16
4812	30	17	202	200	22
4812	33	17	232	232	22
4812	36	17	266	270	20
4812	42	17	346	358	18



6.2. Approximate Concrete Requirements

Table 3. Approximate Concrete Requirements (cu. yd.) - Bin Diameter / Round Pit Combinations

BIN SIZE DIA.(ft.)	CIRC-AIR DIA.(ft.)	GRAIN BIN/ FOUNDATION TYPE					
		SC SERIES MODEL		WC FARM SERIES		SEALFORM	STIFF-CORR
		144-196	197 & 198	3 - 7 TIERS	8&9 TIERS	9 TIERS MAXIMUM	9 TIERS MAXIMUM
14	12	5					
19	12	9	13			9	
	15	7	10			7	
15	12			6		5	
18	12			10		8	
	15			7		6	
21	12			14	16	12	17
	15			12	13	10	14
24	15			17	19	15	21
	18			15	16	12	18
27	15			24	26	21	28
	18			21	23	18	25
	21			17	19	15	21
30	18			28	30	25	34
	21			24	26	21	29
	24			20	22	17	25
33	18			35	39	31	42
	21			31	35	27	38
	24			28	30	24	33
	27			23	25	20	28
36	21			40	44	35	47
	24			36	40	31	43
	27			31	34	27	38
	30			26	29	23	32
42	24			60	60	48	65
	27			55	55	44	60
	30			49	49	40	54
	33			43	43	35	47
	36			36	36	29	40
48	30			73	73		77
	33			67	67		71
	36			60	60		54
	42			44	44		47

6.3. Material List

Table 4. Round Pit Aeration System Material List

BIN DIA	PIT DIA	CIRC-AIR KIT P/N *	DUCT KIT BUNDLE QTY	TOTAL SHIPPING WT.
		.050 PERF.	P/N 198163 **	.050 PERF.
14	12'	198150	1	483
19	12'	198150	2	527
	15'	198151	2	743
15	12'	198150	1	483
18	12'	198150	2	527
	15'	198151	1	699
21	12'	198150	3	571
	15'	198151	2	743
24	15'	198151	3	787
	18'	198152	2	992
27	15'	198151	4	831
	18'	198152	3	1036
	21'	198153	2	1276
30	18'	198152	4	1080
	21'	198153	3	1320
	24'	198154	2	1604
33	18'	198152	5	1124
	21'	198153	4	1364
	24'	198154	3	1648
	27'	198155	2	1957
36	21'	198153	5	1408
	24'	198154	4	1692
	27'	198155	3	2001
	30'	198156	2	2367
42	24'	198154	6	1780
	27'	198155	5	2089
	30'	198156	4	2455
	33'	198157	3	2858
	36'	198158	2	3296
48	30'	198156	6	2543
	33'	198157	5	2946
	36'	198158	4	3384
	42'	198159	2	4377

* Pit Kit contents listed in [Section 6.4. – Pit Kit Contents on page 34](#)

**Double quantity of duct kit when using an unload auger. These parts must be ordered separately.

Note

Aeration Planks are supplied as a floor plank bundle according to the pit diameter. Bundles contain a full floor manual and flashing screws. Check the full floor manual for materials required and ensure all items were received.

Fan transition must be ordered separately to suit your installation's fan size.

Floor supports are ordered separately in accordance with support placement schedule quantities.



6.4. Pit Kit Contents

Table 5. Pit Kit Contents

PIT DIA	FLOOR PLANK BUNDLE	FORM SHEET BUNDLE	FLASHING BUNDLE	HARDWARE PAILS *	SHIP. WT.
	.050 PERF.				.050 PERF.
12'	198070	196561W	196561F	196481	439
15'	198072	196562W	196562F	196482	655
18'	198073	196563W	196563F	196483	904
21'	198075	196564W	196564F	196484	1188
24'	198076	196565W	196565F	196485	1516
27'	198077	196566W	196566F	196485	1869
30'	198078	196567W	196567F	196481 + 196482	2279
33'	198079	196568W	196568F	196481 + 196482	2726
36'	198080	196569W	196569F	196481 + 196482	3208
42'	198082	196570W	196570F	196482 X 2	4289

* Hardware pail contents listed in [Section 6.6. – Hardware Package Contents on page 34.](#)

6.5. Duct Kit Contents

Table 6. Duct Kit Contents

DUCT WALL FORM QTY. P/N 196479	NON-PERFORATED PLANKS P/N 198139	ROUND PIT FLASHING P/N 196478
2	2	6

WEIGHT: 42 lbs.

6.6. Hardware Package Contents

Table 7. Hardware Package Contents

HARDWARE PAIL	3/8" x 1" BOLT (BAG OF 50) 235943	3/8" x 1" BOLT (BAG OF 325) 235941	3/8" FLANGE NUT (BAG OF 50) 235955	3/8" FLANGE NUT (BAG OF 300) 235954	#10 x 3/4" SCREW 900461	LEVELLING BRACKET 235587	DUCT ANGLE 196477	CENTER PIVOT 235311	SCREEDER BRACKET 196486	INSTALLATION INSTRUCTIONS 198827
196481	4		4		60	48	8	1	2	1
196482	5		5		60	62	8	1	2	1
196483		1		1		76	8	1	2	1
196484		1	1	1		82	8	1	2	1
196485	1	1	2	1	60	96	8	1	2	1

7. Limited Warranty: Westeel Grain Bin Products

Westeel – Ag Growth International ("Westeel") warrants products that it has manufactured and/or that are branded with its name (the "goods") subject to the following terms and limitations, (the "warranty"):

Duration of Warranty

This warranty will run from the date of purchase from the dealer or distributor, authorized by Westeel. The duration of the warranty is limited as follows:

Galvanized Bins	5 years
EasyFlow2	24 months
Westeel Fans	36 months
Floors	12 months
Catwalk	12 months
Bulk Feed Tanks	24 months
SeedStor-K Cones	
Paint	12 months
Structural	30 months
Elite Cones	
Paint	30 months
Structural	10 years
WESTEEL cones	
Paint	No Warranty
Structural	12 months
Smooth Wall Bins	
Paint	60 months
Structural	10 years
Commercial Smooth Wall Bins	
Paint	12 months
Structural	10 years

Limitation of Remedies Replacement

Within the warranty period, Westeel will replace the goods and/or original manufactured components thereof which are found, to Westeel's satisfaction, to be defective. Westeel is not responsible for direct, indirect, special, consequential, or any other damages of any kind, including personal injury to any individual, howsoever caused, including caused by transportation of the goods for repair or replacement.



Procedure for Obtaining Service

In the event of a warranty claim, the purchaser must complete any and all information required by Westeel in order to properly assess or investigate the claim. Westeel will not be responsible for the removal of any of the goods found to be defective, or transportation charges to and from Westeel's authorized dealer or distributor, or for installation of any replacement goods and/or parts furnished under the warranty.

Limitations as to Scope of Warranty

The warranty does not extend to defects or damage caused, in whole or in part, by:

1. use of a kind and/or to a degree not reasonably expected to be made of the goods;
2. improper storage of the goods both prior to and after purchase;
3. damage caused by, or in the course of, installation or assembly;
4. any use of the goods which is not an intended use as specified in Westeel's published product literature, or otherwise specified by Westeel in writing;
5. any equipment attached to or used in conjunction with the goods;
6. any field modifications or substitutions to original bin components;
7. inadequate ventilation or any other circumstance not in keeping with proper maintenance and/or use of the goods;
8. Acts of God, accident, neglect or abuse of the goods by the purchaser and/or any other individual or entity; or
9. Any use or installation inconsistent with Westeel's Standard Disclaimers.

Limitations as to Manufacturer

The warranty does not cover products sold by Westeel that are not manufactured by Westeel. In those circumstances, the purchaser is referred to the manufacturer of those products.

Limitation of Implied Warranties and Other Remedies

To the extent allowed by law, neither Westeel nor its dealers, nor any company affiliated with Westeel makes any warranties, representations, or promises as to the quality, performance, or freedom from defect of any Product covered by this Warranty.

WESTEEL HEREBY DISCLAIMS, TO THE EXTENT APPLICABLE, ANY AND ALL IMPLIED WARRANTIES OF MERCHANTABILITY AND FITNESS FOR A PARTICULAR PURPOSE. A PURCHASER'S ONLY REMEDIES IN CONNECTION WITH THIS WARRANTY ARE THOSE SET FORTH IN THIS WARRANTY. IN NO EVENT WILL WESTEEL, ITS DEALERS, OR ANY COMPANY AFFILIATED WITH WESTEEL BE LIABLE FOR INCIDENTAL, CONSEQUENTIAL OR PUNITIVE DAMAGES.

Some jurisdictions do not allow waivers of certain warranties, so the above waivers may not apply to you. In that event, any implied warranties are limited in duration to ninety (90) days from delivery of the products. You may also have other rights which vary from jurisdiction to jurisdiction.

Exclusive Warranty

This warranty is the only warranty provided by Westeel and all other warranties and/or commitments, whether express or implied and no matter by whom made, statutory or otherwise, are subsumed and replaced by it and are of no legal effect. If any provision of the warranty is held by a court of

competent jurisdiction to be void or unenforceable, in whole or in part, such provision shall be deemed severable and will not affect or impair the legal validity of any other provision of the warranty.





450 Desautels Street
P.O. Box 792
Winnipeg, Manitoba, R3C 2N5 Canada
Phone: (866) 299-4312
Fax: (204) 235-0796

Website: www.westeel.com
Email: info@westeel.com
©Ag Growth International Inc. 2018
Printed in Canada
