



The Dallas Retro® Style Awning
OWNER'S MANUAL & INSTALLATION INSTRUCTIONS

Important Installation Information:

The Dallas Retro® frame must be installed on the wall as there is no connecting part between Projection Bar (BP) and Top Bar (TB).
Please read instructions fully before installing.

WARNING: CHOAKING HAZARD – Contains small part, and Sharp metal. CAUTION: When you are opening the box keep children away. Be extremely cautious around children.

Models with Valance:

RR22, ER23, CR32, CR34, CR43, CR44, ER2442, ER12, ER1836, ER1230, ER1230, ER1030, ER24, CR33

Models without Valance:

RR22-NV, ER23-NV, CR32-NV, CR34-NV, CR43-NV, CR44-NV, ER2442-NV, ER12-NV, ER1836-NV, ER1230-NV, ER1030-NV, ER24-NV, CR33-NV

Awning size	Width in inches	Awning Size	Width to Inches
3	40.5	12	148.5
4	52.5	13	160.5
5	64.5	14	172.5
6	76.5	15	184.5
7	88.5	16	196.5
8	100.5	17	208.5
9	112.5	18	220.5
10	124.5	19	232.5
11	136.5	20	244.5

OUR AWNINGS ARE DESIGNED 4.5" WIDER THAN STANDARD WINDOW/DOOR OPENINGS SO THEY ANCHOR TO THE STUDS AROUND THE WINDOW OR DOOR. EXAMPLE: RR22-5 IS FOR 5'-0" WIDE WINDOW. IT MEASURES 64.5" WIDE, 31" TALL, (24" PLUS 7" VALANCE AND 24" DEEP (PROJECTION))

There are a variety of building wall surfaces, Awntech does not supply the hardware to install your awning. You will need to purchase installation hardware at your local hardware store. We have advised you on different surface applications below:

CONCRETE BLOCK WALLS: (1) 1/2" masonry bit with a 3/8" shank, (4-5) 5/16"x3" Masonry anchor bolts, 9/16" socket. You will also need a roll of weather stripping.

METAL BUILDINGS: (1) 2X6X8 #2YP Cut into 12" blocks for the back side of the metal, (4-5) 5/16"x4" lag bolts, (4-5) 5/16" washer, rubber installation strips (in the shape of the metal) and 3/8" drill bit. Bolt through the washer, the bracket and the metal into wood blocks behind the metal. Before tightening the bracket insert the rubber strips between the building and the awning.

ANY TYPE OF SIDING: (4-5) 1/4"x4" toggle bolts, (4-5) 1/4" washers, (1) Flat head screwdriver, (1) 1/2" drill bit (or if you hit a stud) ; (5-8) 5/16"x4" lag bolts, (4-5) 5/16" washers, (1) 3/16" drill bit and a 9/16" socket, you will also need a roll of weather stripping.

CONCRETE, BRICK OR STONE: (1) 1/2" Masonry bit with a 3/8" shank, (4-5) 5/16"x3" masonry anchor bolts, (4) 5/16"x4" bushings, 9/16" sockets. You will also need a roll of weather stripping.

Stucco: (4-5) 1/4"x4" toggle bolts, (4-5) 1/4" washers, (1) flat head screwdriver, (1) 1/2" drill bit (or if you hit a stud): (4) 5/16"x4" lag bolts, (4-5) 5/16" washers, (1) 3/16" drill bit and a 9/16" socket. You will need a roll of weather stripping.

PARTS:

Awning Size in Ft.	2	3	4	5	6	7	8	9	10	11	12	13	14	15	16	17	18	19
(TB) Top Bar – C Channel	1	1	1	1	2	2	2	2	2	3	3	3	3	3	3	3	3	3
(FB) Front Bar	1	1	1	1	2	2	2	2	2	3	3	3	3	3	3	3	3	3
(NC) Hypotenuse/Cover Support		2	2	3	3	3	5	5	5	5	5	5	7	7	7	7	7	7
(BP) Black Projection Bar	2	2	2	3	3	3	5	5	5	5	5	5	7	7	7	7	7	7

Other parts: Z-Brackets, Self tapping Screws

All awning sizes over 9' wide come in to sections. Example: Top Bar (TB) consists of TB1 & TB2 and Front Bar (FB) consist of FB1 & FB2

Tools Required: Electrical Drill, 1/4" Nut Driver Bit, Full Socket Set, Full set of Steel and Masonry Bits, Tape Measure, Safety Glasses, 4' Level, A Safe Ladder, #2 Pencil

YOU MAY ALSO NEED AN ASSISTANT FOR LARGER AWNINGS. IT DEPENDS ON THE SIZE AND WEIGHT OF THE AWNING.

NOTE: YOU WILL FIND THAT THE FITTINGS HAVE BEEN PRE-INSTALLED, AS WE HAVE PRE-ASSEMBLED AND INSPECTED IT FOR YOU IN THE FACTORY.

The Dallas Retro® frame must be installed on the wall as there is no connecting part between Projection Bar (BP) and Top Bar (TB)

STEP 1: Separate all of the parts, so they will be easy to assemble.

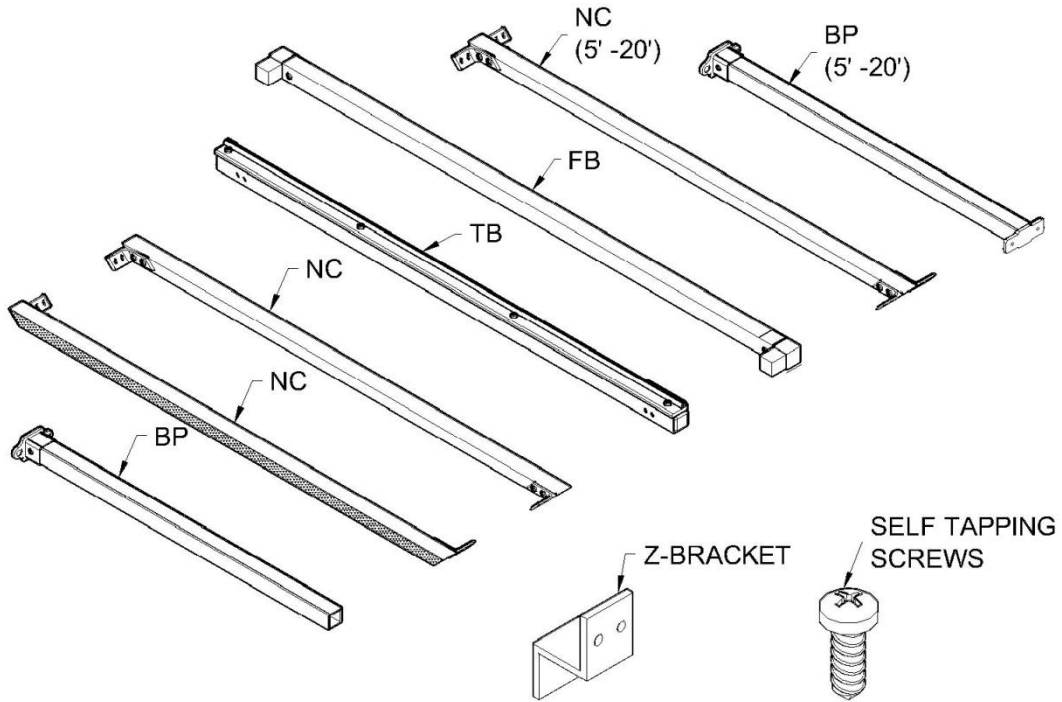

STEP 2: The Top Bar (TB) must be installed first. Mount Provided Z-Brackets to surface, and insert TB into brackets. The C-Channel must be close to the wall. Before installing the TB you must make sure that there is enough space below to install BP. (please see the chart below for the height measurements)

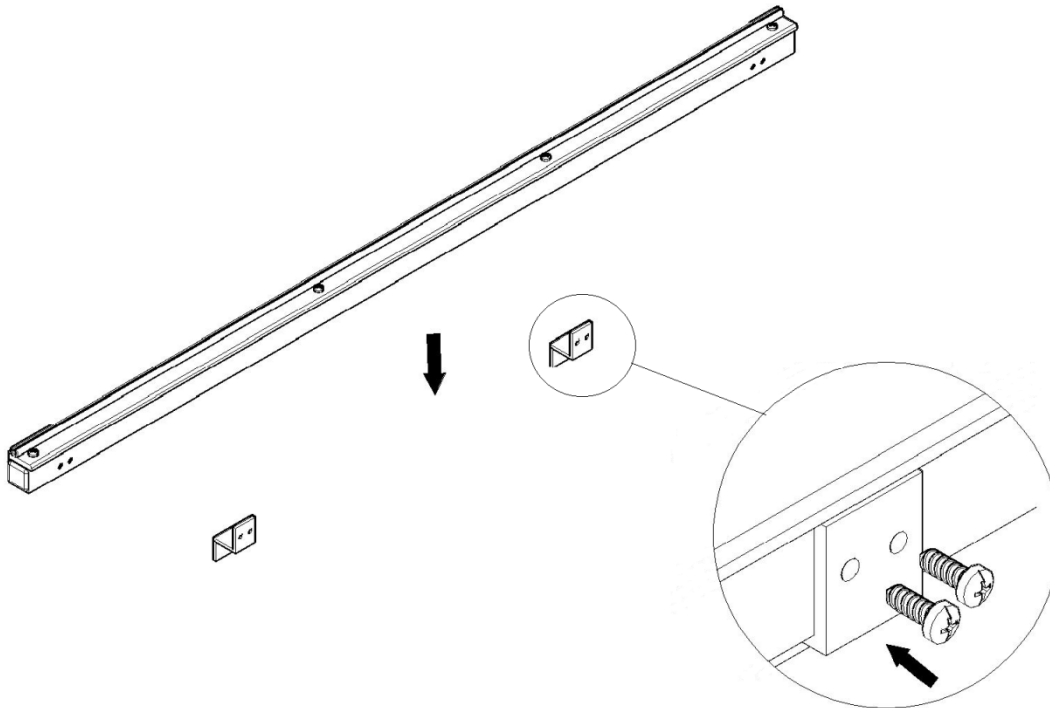

STEP 3: Insert the L shaped plastic ends of the Front Bar (FB) in to Left and Right Black Projection Bar (BP) and then secure them with self tapping screws. The Velcro on the (FB) faces towards you. *Note: You may have received one of the older models; your Velcro will be on top of the FB, Pay close attention to the black Angle ends.

Frame 2'-4'

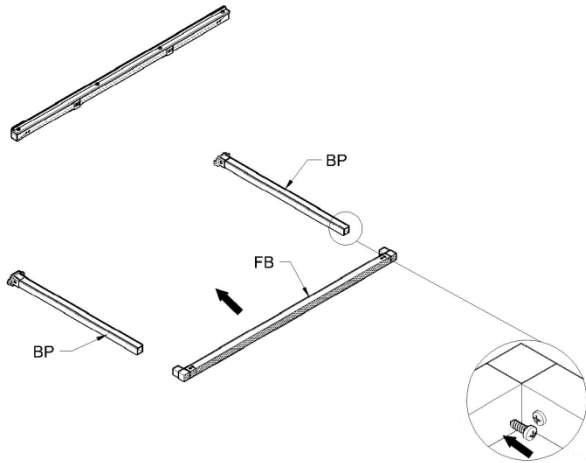

Frame 5'-7'

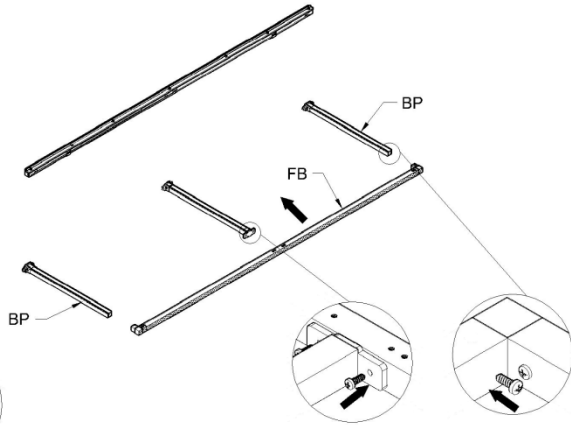

STEP 4: Install the BP & FB structure to the mounting surface. The space between the top of the (TB) and the bottom of the (BP) is indicated on sheet 5.

Frame 2'-4'

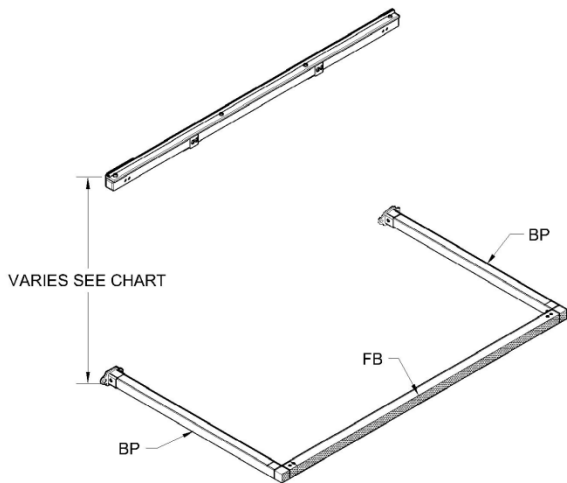

Frame 5'-7'

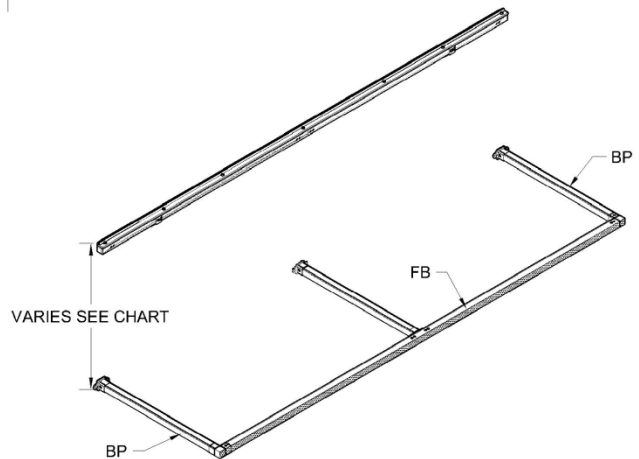

***all the sizes are in inches

Model	Space between TB and BP in inches	Height incl. Valance	Projection	Model	Space between TB and BP in inches	Height incl. Valance	Projection
RR22	24	31	24	RR22-NV	24	24	24
CR32	36	44	24	CR32-NV	36	36	24
CR33	36	44	36	CR33-NV	36	36	36
CR34	36	44	48	CR34-NV	36	36	48
CR43	48	56	36	CR43-NV	48	48	36
CR44	48	56	48	CR44-NV	48	48	48
ER2442	18	24	42	ER2442-NV	24	24	42
ER12	8	12	24	ER12-NV	12	12	24
ER1836	12	18	36	ER1836-NV	18	18	36
EE1230	8	12	30	EE1230-NV	12	12	30
ER1030	10	16	30	ER1030-NV	16	16	30
ER23	18	24	36	ER23-NV	24	24	36
ER24	18	24	48	ER24-NV	24	24	48

STEP 5: Install the NC (left and right) with arrow facing upwards. Secure them with self tapping screws, The holes on the (FB) and (TB) are pre-drilled. Make sure that the Velcro on NCs are facing outwards. *Note: You may have received one of the older models; your Velcro will be on the inside of the NC. Just Make sure the NC bars are flush to the ends of the FB and TB

Note: If the awning is larger then 4' (52.5") wide then you must install additional (NCs) and (BPs) to complete the frame assembly and installation.

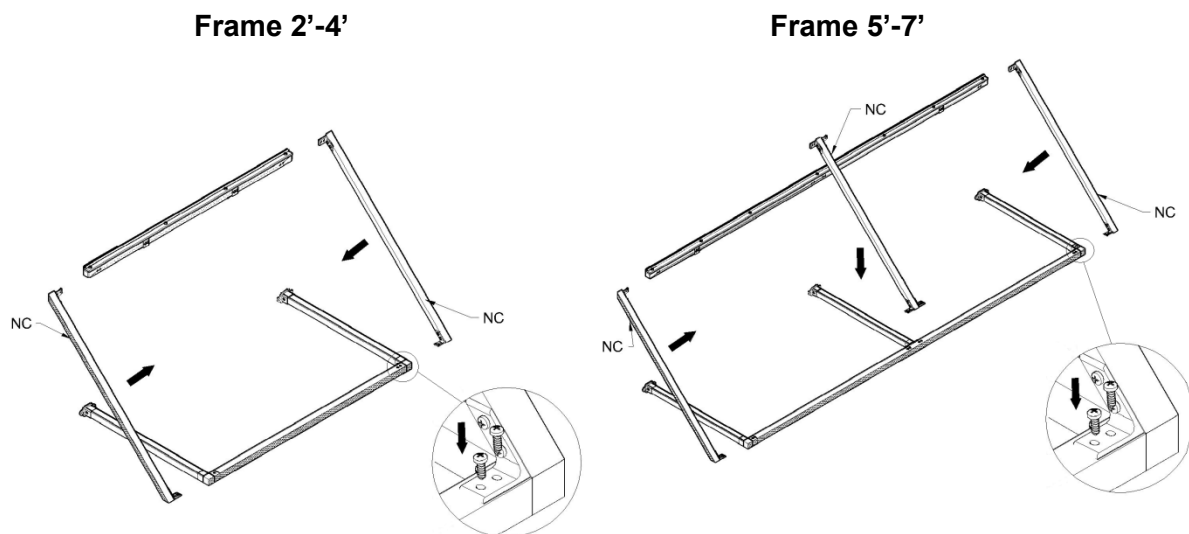

The Frame for The Dallas Retro® is complete.

Frame 2'-4'

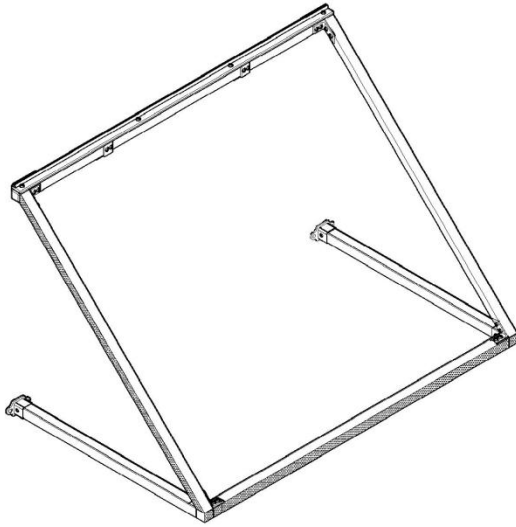

Frame 5'-7'

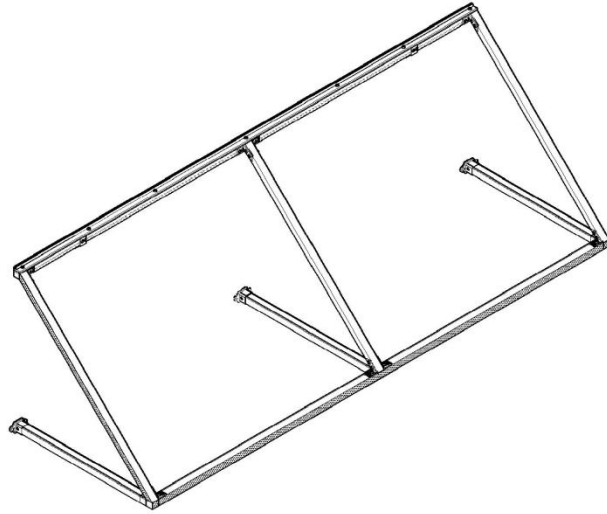

INSTALLING THE COVER

STEP 6: Slide the tubing at the top of the fabric cover into the C-Channel on the top of (TB).

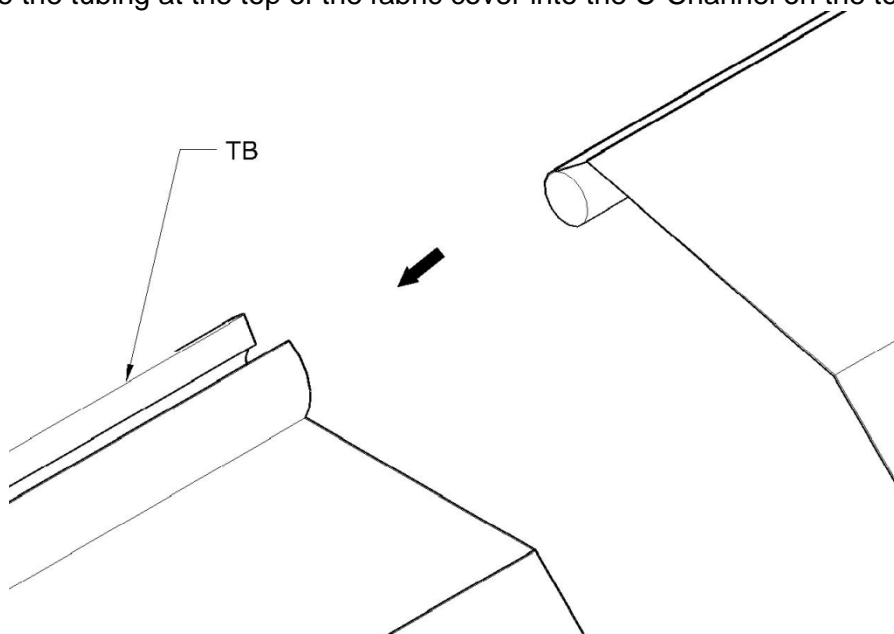

STEP 7: Pull the remainder of fabric over the fame with the valance hanging down below the (NC) and (FB) bars.

Frame 2'-4'

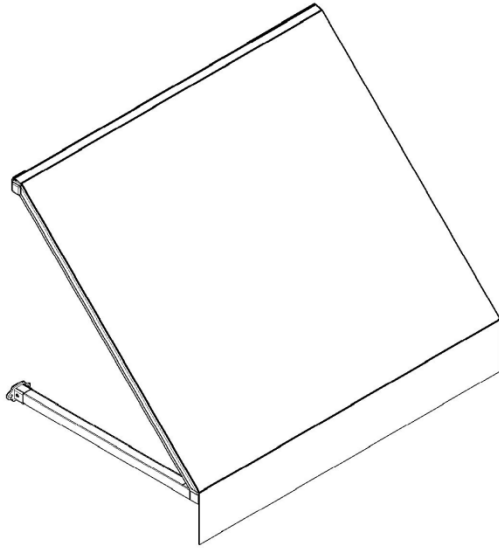

Frame 5'-7'

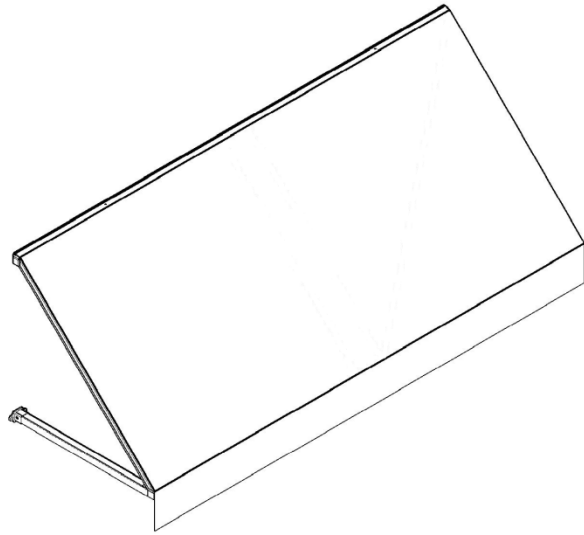

STEP 8: Once you are satisfied with the position of the cover, Pull the tabs snugly and attach them to the pre-installed Velcro tape on the bars.

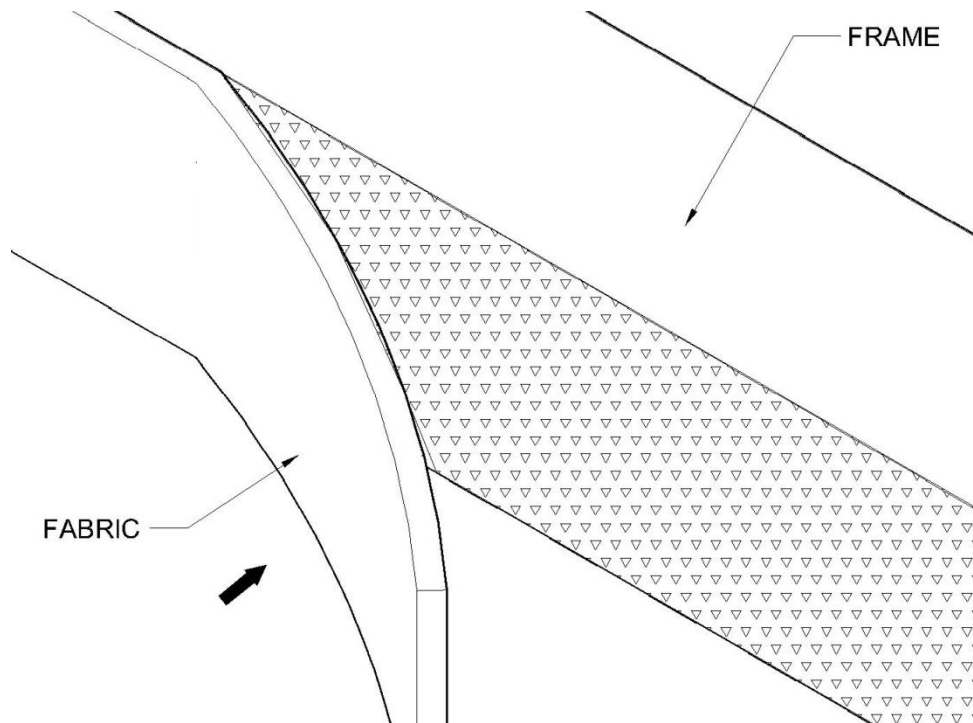

CLEANING & CARING

NORMAL WEAR & TEAR:

Certain regions of the country are extremely hard on awnings of any kind. If you live in these areas, (High maintenance areas: FL, TX, NM, AZ, NV or high altitude areas) you probably already know how the sun can take a toll. Normal wear and tear is not covered in our warranty and should be expected. Damages caused by improper anchoring, strong winds, snow or ice are not considered defects. We offer replacement fabric at affordable prices.

CLEANING & CARING:

Awnings should be cleaned at least once a year in low maintenance areas or twice a year in high maintenance areas (see high maintenance areas above). Cleaning consist of brushing off debris with broom, brushing on a non-detergent cleaning compound (such as 1/2 Vinegar, 1/2 water), letting it sit for 20 minutes and rinsing. Remember that your awning is an exterior product, You'll need to clean your awning to preserve and extend its beauty and life. Please refer to the cleaning and care chart below if you acquire a stain from one of the ingredients on the list.

CLEANING CHART FOR TYPICAL AWNING STAINS

STAIN	RECOMMENDED CLEANING SOLUTIONS
CHARCOAL	Vacuum, then liquid detergent
CHEWING GUM	Acetone
SODA	Liquid detergent
CAR GREASE	Acetone
IRON RUST	Oxalic or citrus acids, water
MILDEW	1 cup of bleach and ¼ mild soap per gallon of water
OIL	Acetone
PAINT (LATEX) WET	Liquid detergent, water
PAINT (LATEX) DRIED	Paint, oil or grease remover
PAINT (OIL OR LACQUER)	Paint, oil or grease remover
SUNTAN LOTION	Pine Power® or pine oil detergent
TREE SAP	Turpentine, liquid detergent

WARRANTY

5-Year Manufacturer's Limited Warranty
1-Year Manufacturer's Limited Warranty (CALIFORNIA)

Obtaining necessary permits is the sole responsibility of the purchaser.

Purchaser/customer agrees he/she/company will NOT hold Awntech liable for improper installation, maintenance and repairs.

A. CALIFORNIA MODEL WARRANTY: The warranty will be same as it is described below except where it says 5 year term will be replaced by a 3-year term.

B. WHO GIVES THIS WARRANTY? Awntech Corporation, 10950 S. Pipeline Road, Euless, TX 76040

C. WHO IS ENTITLED TO THIS WARRANTY?

This Warranty applies only to the original purchaser who paid for the product and may not be assigned or transferred to subsequent owners. This Warranty applies only to products purchased and installed in the United States.

D. WHAT ARE THE RESPONSIBILITIES OF AWNTECH UNDER THIS WARRANTY?

Subject to the terms and conditions set forth herein, Awntech Corporation will furnish replacements for parts found by Awntech Corporation to be defective in design, manufacture or assembly, under each specific component or product warranty as set forth below.

E. WHAT ARE THE RESPONSIBILITIES OF THE ORIGINAL PURCHASER UNDER THE WARRANTY?

•Before any claims may be made under this Warranty, the original purchaser must have paid in full for the product covered under the Warranty, according to the terms and conditions of the pay-plan defined in the original order. IF THE PURCHASER HAS FAILED TO MAKE FULL PAYMENT, THIS WARRANTY SHALL BE NULLIFIED AND AWNTECH CORPORATION SHALL BE RELIEVED FROM ANY RESPONSIBILITY OR LIABILITY UNDER THIS WARRANTY. The purchaser agrees and

acknowledges that this Warranty agreement constitutes an executor contract.

- The purchaser must use care in installation, maintenance, operation, use, and storage of the product in accordance with the instructions contained in the

owner's manual. ANY FAILURE TO INSTALL, MAINTAIN, OPERATE, USE AND STORE THE PRODUCT IN ACCORDANCE WITH THE INSTRUCTIONS CONTAINED IN THE OWNER'S MANUAL WILL NULLIFY THIS WARRANTY AND RELIEVE AWNTTECH CORPORATION FROM ANY RESPONSIBILITY OR LIABILITY UNDER THIS WARRANTY.

- Promptly notify Awntech Corporation of any claims.

- The purchaser may be required to provide a photograph of any defective parts. The purchaser may also be required to pay a deposit until the defective parts are returned to Awntech Corporation for inspection. The purchaser must obtain a return authorization form from Awntech Corporation's customer service department prior to the return of any merchandise and after having received such authorization, return the part or product, freight prepaid, to Awntech Corporation.

F. WHAT IS COVERED UNDER THIS WARRANTY?

The following components of Awntech Beauty-Mark® models and their accessories (defined as accessories attached to the awning) are covered under this Warranty, subject to the limitations set forth below. These components have a five (5) year limited (prorated) warranty, against manufacturer's defects as outlined below:

(a) Should the purchaser promptly notify Awntech Corporation of such defects within one year (12 months) from the date of the original purchase, the defective component will be replaced at no charge. Awntech reserves the right to ask for the defective part to be returned and/or photos of the defective part. CALIFORNIA MODEL WARRANTY: The warranty will be same as it is described below except where it says 5 year term will be replaced by a 1-year term.

(b) (b) After one year but within five years (60 months) from the date of the original purchase, a defective component will be replaced upon the purchaser's payment of 1/60th of the full retail cost of the component for each month of use prior to the claim.

FIXED AWNINGS – COVERED COMPONENTS

Structural supports - all supporting components are warranted not to fail for five (5) years provided that the components

Acrylic fabric - warranted for five (5) years against:

a) excessive fading under normal conditions if maintained, operated, used, and stored in accordance with the instructions contained in the owner's manual.

b) mildew on acrylic fabric. Mildew will not form on the fabric itself, but may form on dirt and dust that have not been removed from it. Please see maintenance instructions for proper cleaning—outlined in owner's manual.

G. WHAT IS NOT COVERED UNDER THIS WARRANTY?

- The Awntech Manual & Motorized retractable awnings up to 24 feet long are designed for residential uses only, and not for commercial uses. The Awntech retractable

awnings are also not designed to be used for carports. Any damage that results from the purchaser's use of the Awntech Maui awnings for commercial uses or for carports is not covered by this Warranty.

- Any failure or damage of the components that results from any intentional or negligent actions by the purchaser or by any other person is not covered by this Warranty.

This includes leaving retractable awnings extended during harsh weather.

- It is the responsibility of the purchaser to securely fasten the awning to studs, joists, headers or other structural members. Any failure or damage that results from the

awning falling from its installed position is not covered by this Warranty.

- Labor charges connected with installation of replacement parts are not covered by this Warranty.

- Freight expenses to and from Awntech Corporation in shipping damaged or replacement parts are not covered by this Warranty and must be paid by the purchaser.

- Stretching of fabric or damage to any structural component caused by wind or water pooling on the fabric or any other weather is not covered by this Warranty, except for the limited warranty of the acrylic fabric as specifically set forth herein.

- Failure or damage to the lateral arms or their components are not covered by this Warranty (explanation in Owner's Manual).

H. GENERAL PROVISIONS AND LIMITATIONS

- The warranty granted herein is the exclusive remedy for the purchaser. Awntech corporation makes no other warranties to the purchaser, express, statutory, implied or otherwise and all implied warranties, including without limitations, implied warranties of merchantability and fitness for a particular purpose, are hereby disclaimed.

- To the extent permitted by law, Awntech Corporation shall have no liability to the purchaser or any other person for incidental, special, consequential, indirect or similar damages of any kind or nature whatsoever, whether arising out of breach of warranty or other breach of contract, negligence or other tort, or otherwise, even if awntech corporation shall have been advised of the possibility or likelihood of such potential loss or damage. In no event shall awntech corporation be liable for loss of profits and/or wages.

- Some states do not allow limitations on how long an implied warranty lasts, or do not allow the exclusion or limitation of incidental or consequential damages, so the above limitations may not apply to you.

- This warranty gives you specific rights, and you may have other rights, which vary from state to state.

Awntech Corporation, 10950 S. Pipeline Rd., Bldg. 1, Euless, TX 76040 / Ph 817-354-9600; Fax 817-354-9612 /

Warranty@awntech.com

RETURNS & DAMAGES

RETURN QUALIFICATION: You can only return a product if it is defective upon arrival. If you simply do not like the product or if you did not measure correctly, you will only be qualified for a merchandise credit and you will be required to pay for shipping the product back to Awntech in re-stockable condition. There will be a 25% restock fee applicable.

DAMAGED MATERIAL: Damage occasionally occurs during shipping. Scrapes, dents and rips in the outer packaging that could indicate possible damage should be described to the carrier at the time of delivery. If damage to the product seems apparent, the shipment should be refused.

FABRIC DYE-LOT AND LIGHTING VARIATION: Fabric dyes may vary slightly from run to run. This is a normal and unavoidable. Different lighting types and lighting direction may cause the fabric you choose on the website to appear slightly different than the actual fabric does in full sunlight.

RETURNS/ORDER EXCEPTION CONTRACT: Phone :817-354-9600, Fax 817-354-9612, E-mail customers@awntech.com TO ACQUIRE A RETURN OR REPAIR AUTHORIZATION NUMBER YOU MIGHT GO THROUGH THE WARRANTY PROCESS: E-mail Photos of damaged parts to: customers@awntech.com or mail to: Awntech Corporation, 10950 S. Pipeline Rd., Bldg 1, Euless, TX 76040

Authorized returns should be shipped to: Returns Department: Awntech Corporation, 10950 S. Pipeline Rd., Bldg 1, Euless, TX 76040