



Precedent[®] Multi-Temp

Precedent multi-temp takes the premier trailer platform in the industry and optimizes it for food distribution.



THE PRECEDENT MULTI-TEMP LINEUP: MORE MULTI-TEMP CHOICES. THAN ANYONE. ANYWHERE.



THE LEADER

Since inventing refrigerated transport in 1938, Thermo King has been the world leader, designing innovative solutions for customers that utilize the latest in efficient technologies while maintaining the reliability and lowest cost of ownership the company is famous for. Add in the unmatched support and factory trained technicians of the Thermo King dealer network and it's clear why Thermo King continues to be the driving force in transport temperature control.



C-600_M

- Allows for multiple temperature zones in one trailer
- CARB-compliant for seven years
- Delivers double digit fuel savings
- Superior temperature control
- Mechanical fuel injection
- <25 Horsepower engine
- Connected straight from the factory

Refrigeration Capacity

(System net cooling capacity at 100°F ambient and high speed engine operation)

	Engine Power w/ETV	
	BTU/hr	Watts
35°F	52,000	16,115
0°F	32,000	9,376
-20°F	20,000	5,860
Heating Capacity (System net heating capacity at 35/0°F ambient)		Engine Power
BTU/hr	48,000	

THE PRECEDENT S-SERIES

THE ONLY EVERGREEN CHOICE

Developed to achieve Evergreen CARB and EPA emissions compliance* while adding performance, the Precedent S-Series is notable for what it does not have: a Diesel Particulate Filter (DPF). Because of frequent stops/starts, light engine loads and low exhaust temperatures, using a DPF to achieve compliance is problematic. When considering the negative impact on engine life and fuel efficiency that a DPF brings, it was clear that a DPF was not a viable solution for units that run in California. Choose the S-Series and you'll avoid the unknowns and risks of DPFs and can rest easy knowing that you're running the only unit available that will be compliant nationwide for as long as you own it.



S-610_M

- Allows for multiple temperature zones in one trailer
- CARB Evergreen
- No need for Diesel Particulate Filter (DPF)
- Delivers double digit fuel savings
- Superior temperature control
- Electronic fuel injection with real-time fuel monitoring and recording
- >25 Horsepower TK488CR engine
- Connected straight from the factory

Refrigeration Capacity

(System net cooling capacity at 100°F ambient and high speed engine operation)

	Engine Power w/ETV	
	BTU/hr	Watts
35°F	57,500	16,852
0°F	30,500	8,939
-20°F	18,000	5,275
Heating Capacity (System net heating capacity at 35/0°F ambient)		Engine Power
BTU/hr		36,000



S-610_{DE}

- Allows for two temperature zones in one trailer without adding remote evaporators
- CARB Evergreen
- No need for Diesel Particulate Filter (DPF)
- Delivers double digit fuel savings
- Superior temperature control
- Electronic fuel injection with real-time fuel monitoring/recording
- >25 Horsepower TK488CR engine
- Connected straight from the factory

Refrigeration Capacity

(System net cooling capacity at 100°F ambient and high speed engine operation)

	Engine Power w/ETV	
	BTU/hr	Watts
35°F	55,000	16,118
0°F	30,000	8,792
-20°F	18,000	5,275
Heating Capacity (System net heating capacity at 35/0°F ambient)		Engine Power
BTU/hr		39,000

* S-Series models, which include the S-610M and S-610DE, already meet Tier 4 final emissions certification by the Environmental Protection Agency (EPA) and California Air Resources Board (CARB). Further, they comply with CARB's Ultra-Low-Emission Transport Refrigeration Unit In-Use Performance Standards (ULETRU).

THE PRECEDENT ADVANTAGE: DELIVERING PERFORMANCE AND VALUE TO YOUR BOTTOM LINE.



TracKing

CONNECTED SOLUTIONS

Every Precedent trailer refrigeration unit comes Connected from the factory powered by TracKing, making it easier for fleets to monitor and analyze their refrigerated fleet operations.

Fleets can save time and money on installation and choose to enable TracKing remotely, gain access to data, and focus on their business without having to take their assets off the road.

Also, fleets can access data for temperature traceability and FSMA compliance while gaining insights into the performance of their refrigeration units.

DIESEL DIRECT ELECTRIC ARCHITECTURE

The Precedent Multi-Temp platform utilizes our unique DDE (Diesel Direct Electric) architecture to drive optimum efficiencies and double-digit fuel savings across real-world applications. It's a smarter approach, with the expressed goal of making a lasting difference on your budget. When creating Precedent, we looked at diesel-electrical and diesel-mechanical designs, and after extensive analysis we chose the best of both. Precedent utilizes DDE architecture to drive optimum efficiencies and double-digit fuel savings and ensures minimal energy loss and maximized fuel efficiency and reliability when compared to an all-electrical solution.



MULTIPLE ZONE CONFIGURATIONS

Choose from numerous configurations within the trailer to best suit your needs:

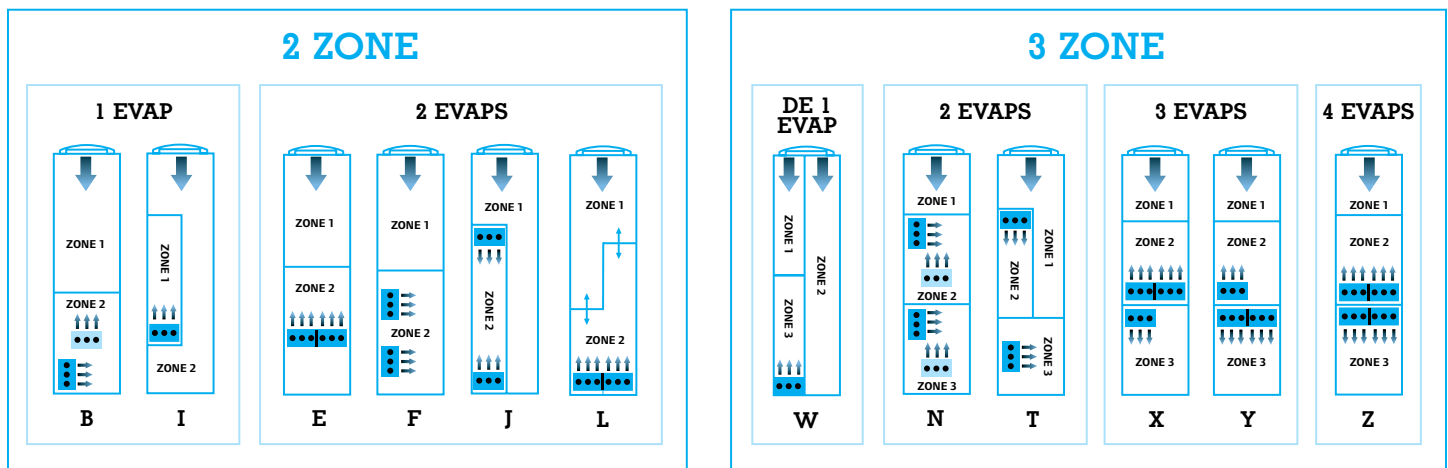

ENGINE CHOICES

The right multi-temp engine choice for your business:

TK486V25L ENGINE (C-600M)

- Mechanical engine
- No external emissions device
- EPA Evergreen
- CARB 7+ Year Life

TK488CR ENGINE (S-610M and S-610DE)

- High-pressure common rail electronically controlled engine
- Best fuel economy
- EPA and CARB Evergreen

CUSTOMIZE WITH THE RIGHT OPTIONS FOR YOUR BUSINESS

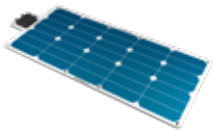

ThermoLite® SOLAR PANELS

ThermoLite Solar Panels can deliver clean, reliable performance in a wide variety of applications, resulting in longer battery life, decreased waste, lower fuel consumption and reduced emissions.



THERMO GARD® ASSURANCE PROGRAMS

Thermo King SVC's Thermo Gard Assurance guaranteed maintenance program includes set programs and a wide variety of coverage options to fit the needs of your business. Your Thermo King dealer can use the new SVC quoting tool to determine which programs can save your business the most time and money!



DOOR SENSORS

Thermo King's door sensors help ensure your load is protected while reducing maintenance costs.



PRIMAIR™ BULKHEADS

Designed and optimized to work with Precedent Multi-Temp, PrimAir Chutes and Return Air Bulkheads help deliver best-in-class airflow and temperature distribution throughout the trailer.



SUPPLEMENTAL POWER KIT

Need a little more power to get you through the day? Look no further than our Supplemental Power Kit. It provides an additional twelve volts of power towards charging the accessory batteries — meaning more juice for your interior lighting, power lift gates, air curtains and more. Available for S-Series units only.



STATUS LIGHTS

Featuring a “can’t miss” display, Thermo King’s status lights increase driver awareness of operational essentials including fuel level and load temperature to reduce the risk of load loss and other costly service issues.



SMARTPOWER AND SMARTPOWER PREP

Run offshore power with three SmartPower options for Precedent. Select the voltage and capacity option that best fits your needs — then rest easy knowing all components are included in our major component warranty coverage. Choose SmartPower Prep and when the time is right, a Thermo King dealer can convert your unit from non-shore power equipped to shore power equipped in less than a day.



Ingersoll Rand (NYSE:IR) advances the quality of life by creating comfortable, sustainable and efficient environments. Our people and our family of brands—including Club Car®, Ingersoll Rand®, Thermo King® and Trane®—work together to enhance the quality and comfort of air in homes and buildings; transport and protect food and perishables; and increase industrial productivity and efficiency. We are a \$13 billion global business committed to a world of sustainable progress and enduring results.



ingersollrand.com

